



39

April  
25 Cents  
Canada 30¢

# Radio-Craft

HUGO GERNSBACK Editor



MORT VROOMAN  
**RADIO SET  
PRINTS NEWSPAPER**

See Page 590

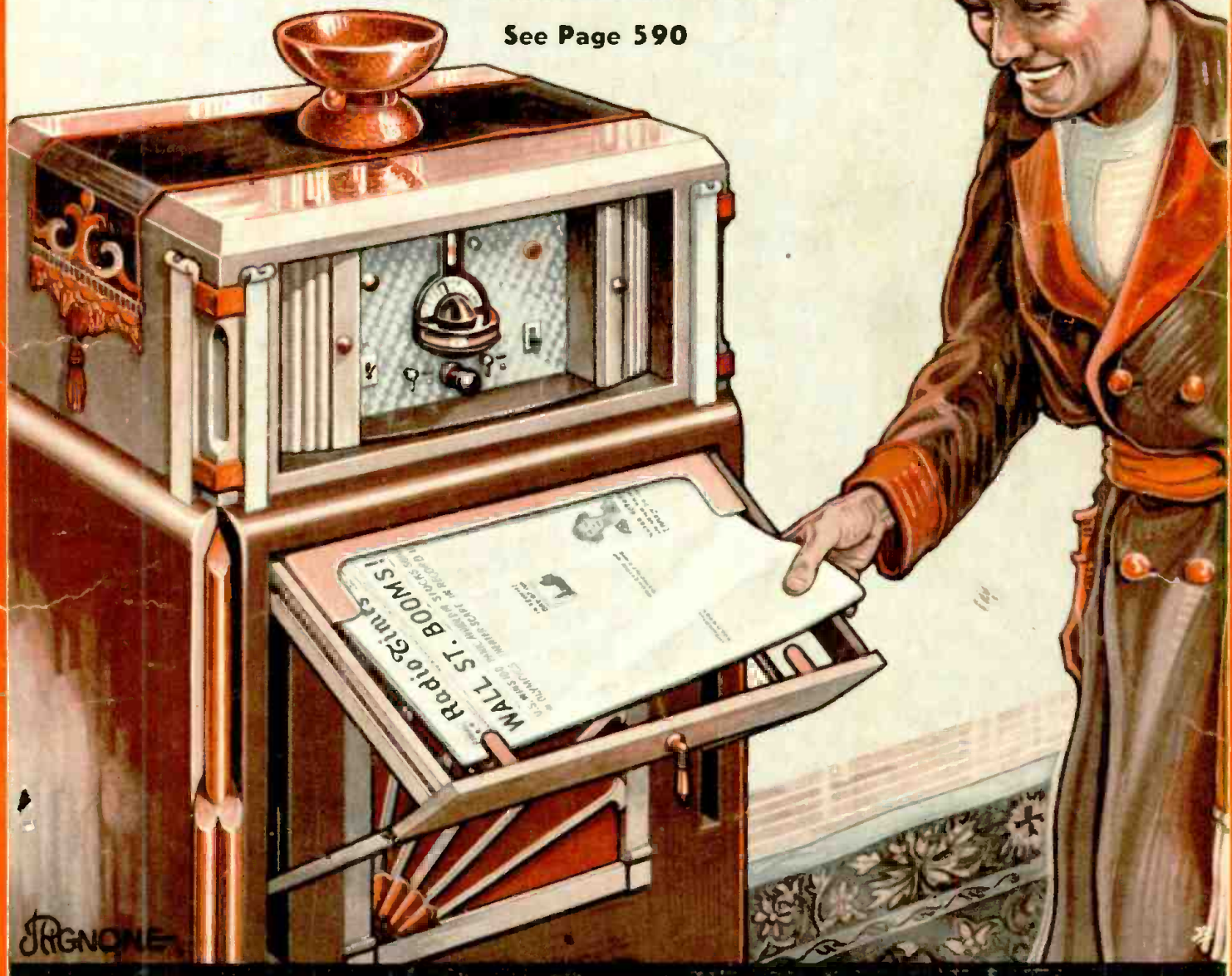

JRGNONE

**20 Ways to Improve Your Set—Auto-Radio Noise—Headphones Coming Back?  
Radio-Controlled Battleships—A Knockabout Tester—Aligning Radio Sets**



# ANNOUNCING

## A GOLDEN OPPORTUNITY FOR ALERT RADIO MEN IN THE NEXT GREAT INDUSTRY



PRE-PUBLICATION  
OFFER

\$4.00

THE idea of electricians, radio service men and other mechanically inclined men, servicing Air Conditioning and Refrigeration Units is self-evident and the thought has occurred to some untold thousands ever since air conditioning equipment has been installed in public auditoriums, theatres, studios, department stores, office buildings and manufacturing plants. The tremendously broad possibilities in this new industry are bound to give employment and success to men far-sighted enough to see its advancement and development. We quote an excerpt from Mr. Hugo Gernsback's editorial which appeared in the September, 1933 issue of *Everyday Science and Mechanics*:

*"I advise young and progressive men to go into the air-conditioning business during the next few years; because, this, without a doubt, is the coming industry in this country. Thousands of small firms will spring up, undertaking to air-condition private houses, small business offices, factories, etc. We are not going to tear down every building in the United States immediately. It will be a gradual growth; yet small installation firms will air-condition small houses, and even single offices in small buildings."*

This is only partial proof of the certain success of this new field. Further assurance is that engineering schools have already added many important courses on air conditioning to their regular curriculum. Architects and building contractors are giving considerable thought to installation of this equipment in structures which are now being planned and built. The beginning of this business will probably be similar to the auto and radio industry, but in a few short years it will surpass these two great fields.

## Official Air Conditioning Service Manual

352 Pages  
Over 600 Illustrations  
9" x 12" in Size  
Flexible, Loose Leaf  
Leatherette Cover



### MAIL COUPON TODAY!

GERNSBACK PUBLICATIONS Dept. RC-434  
96-98 Park Place, New York, N. Y.

Gentlemen: Enclosed you will find my remittance of Two Dollars for which you are to send me One Copy of the OFFICIAL AIR CONDITIONING SERVICE MANUAL, *postage prepaid*, as soon as it comes off the press. I am to pay the additional Two Dollars to postman when it is delivered. It is understood that the regular price of the book will be FIVE DOLLARS when it comes off the press, and I am now paying only a pre-publication price of Four Dollars.

Name \_\_\_\_\_

Address \_\_\_\_\_

City \_\_\_\_\_ State \_\_\_\_\_

(Send remittance in form of check, money order or unused U.S. Postage Stamps. Register letter if it contains stamps or currency.)

The OFFICIAL AIR CONDITIONING SERVICE MANUAL is being edited by L. K. Wright, who is an expert and a leading authority on air conditioning and refrigeration. He is a member of the American Society of Refrigerating Engineers, American Society of Mechanical Engineers, National Association of Practical Refrigerating Engineers; also author of the OFFICIAL REFRIGERATION SERVICE MANUAL and other volumes.

In this Air Conditioning Service Manual nearly every page will be illustrated; every modern installation and individual part carefully explained; diagrams furnished of all known equipment; special care given to the servicing and installation end. The tools needed will be illustrated and explained; there will be plenty of charts and page after page of service data.

Remember there is a big opportunity in this new field and plenty of money to be made in the servicing end. There are thousands of firms selling installations and parts every day and this equipment must be cared for frequently. Eventually air conditioning systems will be as common as radios and refrigerators in homes, offices and industrial plants. Why not start now—increase your earnings with a full- or spare-time service business.

You have the opportunity to get your copy of the OFFICIAL AIR CONDITIONING SERVICE MANUAL today—at a saving of ONE DOLLAR. When the book comes off press, which will be March 15th, the price will be \$5.00 a copy. YOUR ORDER TODAY BRINGS YOU A COPY FOR \$4.00. POSTAGE PREPAID. This is our usual courtesy, pre-publication offer which enables us to determine the approximate print order for the first press run. Send us the coupon today, together with a deposit of \$2.00. When the book reaches you, you pay the other \$2.00.

Here are some of the chapter heads of the AIR CONDITIONING SERVICE MANUAL:

### Contents in Brief

History of Air Conditioning; Fundamental Laws; Methods of Refrigeration; Ejector System of Refrigeration; Compression System of Refrigeration; Refrigerants; Lubricating Oils; Liquid Throttle Devices; Servicing Expansion and Float Valves; Servicing Refrigerating Systems; Control Devices; Thermodynamics of Air Conditioning; Weather in the United States; The Field of Air Conditioning; Insulating Materials; Heat Transmission Through Walls; Complete Air Conditioning Systems; Estimating Requirements for the Home, Small Store, Restaurant; Layout of Duct Systems; Starting Up a System; Operating and Servicing Air Conditioning Systems; Air Filtration, Ventilating and Noise Eliminating Devices; Portable Electric Humidifiers and Room Coolers; Automatic Humidifiers; Air Conditioning Units for Radiator Systems and Warm Air Systems; Central Conditioning Units, etc.

GERNSBACK PUBLICATIONS, INC.  
96-98 Park Place New York, N. Y.

# LEARN RADIO IN 10 WEEKS!

## **PAY** FOR YOUR TRAINING AFTER YOU GRADUATE

I am making an offer that no other school has dared to do. I'll take you here in my shops and give you this training and you pay your tuition after you have graduated. Two months after you complete my course you make your first payment, and then you have ten months to complete your payments. There are no strings to this offer. I know a lot of honest fellows haven't got a lot of money these days, but still want to prepare themselves for a real job so they won't have to worry about hard times or lay offs.

I've got enough confidence in these fellows and in my training to give them the training they need and pay me back after they have their training.

If you who read this advertisement are really interested in your future here is the chance of a life time. Mail the coupon today and I'll give you all the facts.

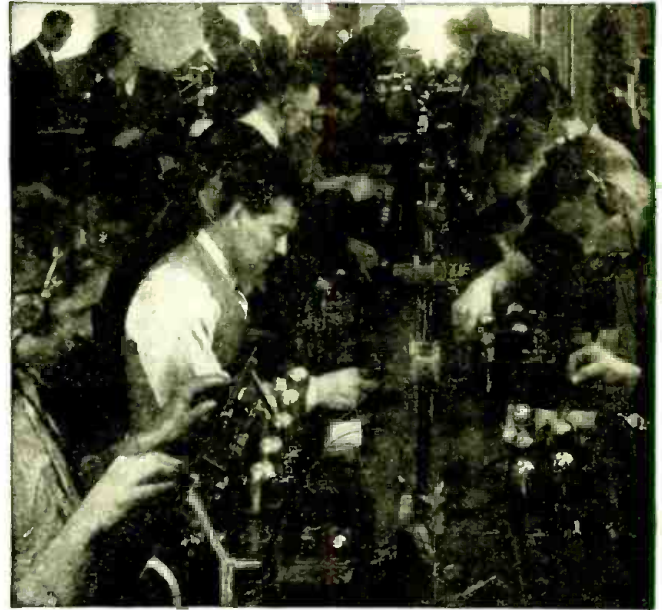

*A scene in the big, busy Radio Shops at Coyne. Here you see fellows working on real Radios—not reading about them from books or lessons. This is THE way to prepare for the big-money field of Radio!*

## TELEVISION *and* TALKING PICTURES

Television is already here! Soon there'll be a demand for THOUSANDS of TELEVISION EXPERTS! The man who learns Television now can have a great future in this great new field. Get in on the ground-floor of this amazing new Radio development! Come to COYNE and learn Television on the very latest, newest Television equipment. Talking Picture and Public Address Systems offer opportunities to the Trained Radio Man. Here is a great new Radio field just beginning to grow! Prepare NOW for these wonderful opportunities! Learn Radio Sound Work at Coyne on actual Talking Picture and Sound Reproduction equipment.

### PREPARE NOW and be ready for Radio's many opportunities

Forget pay-cuts—lay-offs—unemployment! Don't be tied down to an untrained man's future. You NEED TRAINING IN A FAST-GROWING MONEY-MAKING TRADE. Here's your chance of a lifetime to get it! Hundreds of opportunities now open in Radio. My sensational offer, explained below, makes it possible for you to START AT ONCE!

The right way to learn Radio is the Coyne way—not by books, but by actual, practical work on actual Radio, Television and Sound equipment. Here at Coyne you'll service and operate scores of modern Radio receivers, huge Broadcasting equipment, late type Television apparatus, Talking Picture machines, Code transmitters and receivers, etc. In 10 weeks you can step into a REAL JOB, leading to a salary of \$50 a week and UP!

### ALL PRACTICAL WORK At COYNE in Chicago

ALL ACTUAL, PRACTICAL WORK. You build radio sets, install and service them. You actually operate great Broadcasting equipment. You construct Television Receiving Sets and actually transmit your own Television programs over our modern Television equipment. You work on real Talking Picture

machines and Sound equipment. You learn Wireless Operating on actual Code Practice apparatus. We don't waste time on useless theory. We give you the practical training you'll need—in 10 short, pleasant weeks.

### MANY EARN WHILE LEARNING

You get Free Employment Service for Life. And don't let lack of money stop you. Many of our students make all or a good part of their living expenses while going to school and if you should need this help just write to me. Coyne is 33 years old. Coyne Training is tested—proven beyond all doubt. You can find out everything absolutely free. Just mail coupon for my big free book!

**H. C. LEWIS, Pres. RADIO DIVISION Founded 1899**  
**COYNE ELECTRICAL SCHOOL**  
500 S. Paulina St., Dept. 44-8H Chicago, Ill.

#### Mail Coupon Today for All the Facts

**H. C. LEWIS, President**  
**Radio Division, Coyne Electrical School**  
500 S. Paulina St., Dept. 44-8H Chicago, Ill.

Dear Mr. Lewis: Send me your big FREE Book; details of your FREE Employment Service; and tell me all about your special offer of allowing me to pay for training on easy monthly terms after graduation.

Name.....  
Address.....  
City..... State.....





HUGO GERNSBACK, Editor-in-Chief

J. T. BERNSELY, Managing Editor

C. W. PALMER  
Associate Editor

R. D. WASHBURNE  
Technical Editor



## CONTENTS OF THE APRIL, 1934, ISSUE

VOLUME V

Number 10

Editorial: The Radio Power War.....	Hugo Gernsback	581
The Radio Month in Review.....		582
Radio Pictorial .....		584
The Latest Radio Equipment.....		586
Your Service Oscillator.....	Kendall Clough	587
International Radio Review.....		588
Radio Set Prints Newspaper.....	Hugo Gernsback	590
Radio Controls Battleships.....		592
High-Frequency Adjustments in Receivers.....	H. K. Bradford	593
Twenty Ways to Improve Your Radio Set .....	C. W. Palmer	594
Short-Cuts in Radio.....		596
Facts About Dynatron Operation, Part II.....	C. M. Delano	598
How to Make a Novel Portable A.C.-D.C. R.F. Phonograph Attachment.....	R. D. Washburne and N. H. Lessem	599
A New Method for Auto Noise Elimination.....	J. T. Bernsley	600
Servicing the "Talkies," Part VI.....	Aaron Nadell	601
Save Your Old Expensive Tube Tester.....	Milton Reiner	602
Beginner's 3 Tube All-Wave Set.....	F. R. Harris	603
The Knockabout Tester.....	Jack Grand	604
A Combination P.A. Amplifier and Broadcast Tuner L. J. Littman		604
Readers' Department .....		605
A Real Portable P.A. System.....	Hubert Shortt	606
Are Headphones Coming Back?.....		606
Operating Notes .....		607
<b>RADIO SERVICE DATA SHEETS:</b>		
No. 111—RCA—Model 261, 10 Tube Super- heterodyne .....		608
No. 112—Emerson "Auto-Dynamic," 5 Tube Su- perheterodyne .....		609
Information Bureau .....		610

## IN OUR NEXT FEW ISSUES:

**CHOOSING YOUR RADIO SET.** Now that the depression is past and people are looking about for something to spend money on, radio sets are receiving their share of attention. In this article, a careful analysis of the latest "gadgets" found in radio receivers is supplied. From this analysis, you will gain all the information needed to profit by the latest improvements.

**MUSIC IN THIRD DIMENSION.** The radio fan and P.A. worker who thinks that the present day receivers and P.A. installations supply the ultimate in fidelity have a shock awaiting them when they first hear the latest in sound reproduction. With the advancements made in "auditory perspective," present day theatre equipment is almost compared to the tin-horn phonograph of 1920.

**POLYTONE—A NEW ELECTRONIC ORGAN.** Here is a new electronic instrument which can imitate the effects produced on large pipe organs—and it does not have a single pipe in its makeup. Electronic instruments are attracting much attention both in music and radio circles. This one will no doubt achieve considerable fame.

RADIO-CRAFT is published monthly, on the fifth of the month preceding that of date; its subscription price is \$2.50 per year. (In Canada and foreign countries, \$3.00 a year to cover additional postage.) Entered at the post office at Mt. Morris, Ill., as second-class matter under the act of March 3, 1879.

Text and illustrations of this magazine are copyright and must not be reproduced without permission of the copyright owners. We are also agents for WONDER STORIES and EVERYDAY SCIENCE AND MECHANICS. Subscription to these magazines may be taken in combination with RADIO-CRAFT at reduced Club rates. Write for information.

Copyright 1934. Continental Publications, Inc.

HUGO GERNSBACK, President

I. S. MANHEIMER, Secretary

Published by Continental Publications, Inc. Publication office: 404 N. Wesley Ave., Mount Morris, Illinois. Editorial and Advertising Office: 96-98 Park Place, New York City. Chicago Advertising Office: L. F. McClure, 919 North Michigan Avenue, Chicago, Ill. Western Advertising Office: Loyd B. Chappell, 511 So. Alexandria St., Los Angeles, Calif.

London Agent: Hachette & Cie., 3 La Belle Sauvage, Ludgate Hill, E.C. 4  
Paris Agent: Hachette & Cie., 111 Rue Reamur  
Australian Agent: McGills Agency, 179 Elizabeth St., Melbourne

# Learn at Home to Make More Money



**Here's Proof**

**"Made \$6,000 in 2 Years"**

"Soon after the depression started, I found myself without a job, but I was well protected with N. R. I. training. I swung right to full-time Radio servicing and I have made over \$6,000 in a little over two years."  
—W.M. SPARTIVENT,  
Sparty Radio Service, 93 Broadway,  
Newark, N. J.



**"Made \$17 in One Night"**

"Who says there's a depression? I have made more money in Radio than ever before. I am busy day and night. Last night I made \$17. Last week \$15. I had a tough struggle at first but you fellows helped me back in the race and kept me going."  
—J. MAKI, Creighton  
Mine, Ont., Canada.

**"\$500 a Year in Spare Time"**

"Although doing spare time Radio work only, I have averaged about \$500 a year extra in addition to my regular income. Full time Radio work would net me many times that amount."  
—EDW. H. FAWCETT, Slough Rd., Ladner, B. C., Canada.



**"Good Position, Good Pay"**

"I am Chief Operator at Radio Station WSMK. This is a good position with good pay. I have advanced in Radio right along. I recommend N. R. I. to anyone who wants to be successful in Radio."  
—JOHN H. HADYK, JR., 3 Broxey Apis., Southern Hills, Dayton, Ohio.



MAIL THIS TODAY

J. E. SMITH, President  
National Radio Institute, Department 4DX  
Washington D. C.  
Special Offer: Send me your two books "Short Wave Receivers and Transmitters" and "Rich Rewards in Radio." I understand this does not obligate me. (Please print plainly.)  
NAME.....  
ADDRESS.....  
CITY.....  
STATE.....  
82 ER

**I'll train You Quickly for  
Radio's GOOD spare time  
and full time Jobs . . .**

**Mail Coupon  
for FREE  
Information**

Why slave your life away in a no-future job? Why skimp, why scrape, trying to pay your bills? I'll train you quickly for the live-wire field—the field with a future—**RADIO**. \$40, \$60, \$75 a week—that's what many Radio Experts make. \$5, \$10, \$15 a week extra money—that's what many of my students make in their spare time shortly after enrolling. My free book tells you about Radio's spare-time and full-time opportunities—about my tested training—about my students and graduates—what they are doing and making. Get this book. Be a Radio Expert. The Radio field is big enough to absorb many more properly trained men.

**Many Radio Experts Make  
\$40, \$60, \$75 a Week**

Spare-time and full-time Radio Servicing. Operating Broadcast, Aircraft Radio, Commercial Land, Ship and Television stations, a Radio service business of your own. I'll train you for these and other good jobs in the manufacture, sale and service of Radio and Television apparatus. My FREE book tells you about the many money-making opportunities in Radio.

**Save—Learn at home in your spare time**

You don't have to leave home and spend \$500 to \$1,000 to study Radio. I'll train you quickly and inexpensively right in your own home and in your spare time for a good Radio job. You don't need a high school or college education. Many of my successful graduates didn't even finish grade school. My amazingly practical 50-50 method of training—half with lessons, half with Radio equipment—gives you broad practical experience—makes learning at home easy, fascinating, practical and rapid.

**Many make \$5, \$10, \$15 a week extra  
in spare time almost at once**

My book shows how my special training, instruction material, plans, ideas, and my nineteen years' experience training men for Radio careers have helped many students make \$200 to \$1,000 a year quickly in their spare time. My Course is famous as "the one that pays for itself."

**Your money back if not satisfied**

I'm so sure you will be satisfied with my training that I agree in writing to refund every penny of your money if you are not entirely satisfied with my Lessons and Instruction Service when you finish.

**Find out what Radio offers you**

Act today. Mail the coupon. My 64-page book will be sent free to any ambitious fellow over 15 years of age. It tells about Radio's opportunities—explains the eighteen star features of my Course—shows letters of what others are doing and making. There is no obligation. Mail the coupon in an envelope or paste it on a 1c post card.

**J. E. SMITH, President**

**National Radio Institute, Dept. 4DX, Washington, D. C.**

**SAMPLE LESSON FREE**

**Book Explains Short Wave Receivers and Transmitters**



Mail the coupon today, and in addition to my big free book, "Rich Rewards in Radio," I'll send you my text, "Short Wave Receivers and Transmitters." Only my students could get this book in the past. Here's up-to-date information on the latest phase of Radio. 30 pages packed with fascinating details of this important new development. Learn about the new Detector Circuit, Short Wave Coils and Condensers, Audio Amplifier, Short Wave Superheterodyne, etc. Also complete construction details for practical circuits. Mail the coupon at once. Act now—and receive the late technical information on this fascinating subject.



Broadcasting Stations employ managers, engineers, operators, installation and maintenance men for jobs paying up to \$5,000 a year.



Set servicing has paid many N. R. I. men \$200 to \$1,000 a year for their spare time. Full-time men make as much as \$40, \$60, \$75 a week.



Television, the coming field of great opportunities, is covered in my Course.

**Some Other Jobs  
N.R.I. Trains Men For**

- Broadcast Engineer.
- Operator in Broadcast Station.
- Aircraft Radio Operator.
- Operator of Airway Beacons.
- Government Radio Operator.
- Ship Operator.
- Serviceman on Loud Speaker Systems.
- Installation Engineer on Loud Speaker Systems.
- Sales Manager for Retail Stores.
- Service Manager for Retail Stores.
- Auto Radio Installation and Serviceman.
- Television Broadcast Operator.
- Television Engineer.
- Set Servicing Expert.

**MAIL THIS for FREE 64 page book**



# The Radio-Craft Library Series covers accurately every branch of Radio—and thoroughly, too

Presented on this page are the new books of the RADIO-CRAFT LIBRARY—the most complete and authentic set of volumes treating individually, important divisions of radio. Each book has been designed to give radio men the opportunity to specialize in one or more of the popular branches of the industry. The material contained

in these books will increase your knowledge; you will find them a real help in your work and they will contribute to your money earning capacity. Read these books during your spare time at home. The authors of these books are well-known to everybody. Each one is an expert radio man; an authority on the subject—each is thoroughly

familiar with the field which he represents. This is perhaps the first real opportunity that you have ever had to build a radio library of books that are authentic, right-up-to-the-minute and written so that they are easily digested and clearly understood. Mail coupon below for your books.

## TO THE RIGHT WILL BE FOUND A SHORT RESUME OF EACH BOOK

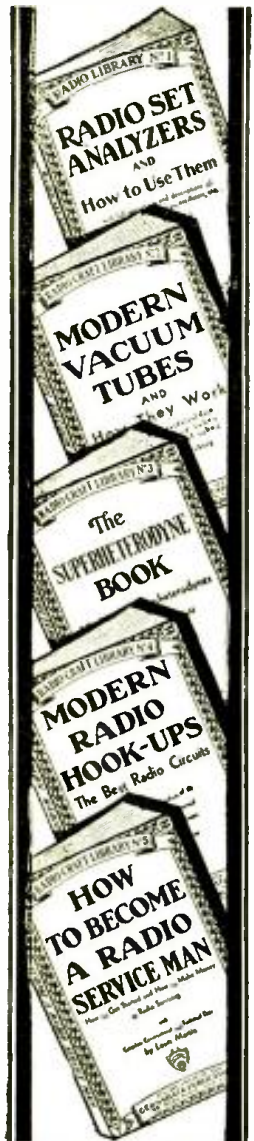

**Book No. 1**  
**Radio Set Analyzers**  
And How To Use Them  
With Full Instructions and Descriptions of Set Analyzers, Tube Checkers, Oscillators, Etc.  
By L. VAN DER MEL  
This book explains thoroughly the operation of set analyzers, tube checkers, oscillators and other testing equipment. For every radio man this book is extremely helpful. It covers every phase of testing and gives you valuable short cuts; completely illustrated with photographs and diagrams to facilitate the use of modern testers. Recently reprinted.

**Book No. 2**  
**Modern Vacuum Tubes**  
And How They Work  
With complete Technical Data on All Standard and Many Special Tubes  
By ROBERT HERTZBERG  
MODERN VACUUM TUBES describes the fundamental electron theory which is the basis of all vacuum tube operation, and goes progressively from the simplest two-element tubes right up to the latest pentodes and thyatrons. It is written in clear, simple language and is devoid of the mathematics which is usually so confusing. Valuable reference charts and characteristic curves of standard and special tubes are to be found, also diagrams of sockets and pin connections.

**Book No. 3**  
**The Superheterodyne Book**  
All About Superheterodynes  
How They Work, How to Build and How to Service Them  
By CLYDE FITCH  
There is no more fascinating a subject in the large array of radio circuits than the famous superheterodyne circuit. Whether you are a Service Man or experimenter, first-hand knowledge about the construction of superheterodyne receivers is very important. The book on Superheterodynes gives underlying principles of their construction, right from the very first set made.

**Book No. 4**  
**Modern Radio Hook-Ups**  
The Best Radio Circuits  
A Complete Compendium of the Most Important Experimental and Custombuilt Receivers  
By R. D. WASHBURNE  
It is fascinating to the experimenter, or even to the up-to-date Service Man, to take a commercial set and to change it into one using a famous hookup that is not found in any manufactured set. Many excellent circuits have never been commercialized, but limited only to home set builders. Thousands of these popular circuits have been requested from time to time, and in this book we have included over 150 circuits, which include the famous Perkydno, Cash-Box, A.C.-D.C. Set and others.

**Book No. 5**  
**How to Become a Radio Service Man**  
How to Get Started and How to Make Money in Radio Servicing  
By LOUIS MARTIN  
The ambition of many men in radio today is to become a first-grade Service Man. It is not as difficult as one might believe, but it cannot be done in a few short months. Following very carefully the advice of Mr. Martin, who has dealt with the problems of thousands of Service Men, this book deals very carefully with the essential stages in the preparation for qualifying as a Service Man.

**Book No. 6**  
**Bringing Electric Sets Up to Date**  
With Pentodes, Multi-Mus, Dynamic Speakers—Complete Information How to Modernize A. C., D. C. and Battery Operated Receivers  
By CLIFFORD E. DENTON  
In this country there are over ten million electrically operated receivers that could be modernized—by placing in them new type tubes, new speaker equipment and other modern improvements. This business of improving old sets can go to the experimenters and Service Men if they will quickly jump into action.

**Book No. 7**  
**Radio Kinks and Wrinkles**  
For Service Men and Experimenters  
A Complete Compendium on the Latest Radio Short-Cuts and Money-Savers  
By C. W. PALMER  
It often becomes necessary for experimenters and Service Men to call upon their memory for some short cut or radio wrinkle that will solve a problem quickly. In business, "short cuts" mean time and money saved, and to the Service Man "time saved" means money earned.

**Book No. 8**  
**Radio Questions and Answers**  
A Selection of the Most Important of 5,000 Questions Submitted by Radio Men During the Course of One Year  
By R. D. WASHBURNE  
There have been collected a wide variety of questions which have come into our editorial offices during the past two years, and only those whose answers would benefit the majority of men engaged in radio have been incorporated in this amazing question and answer book. A tremendously long list of topics is treated.

**Book No. 9**  
**Automobile Radio and Servicing**  
A Complete Treatise on the Subject Covering All Phases from Installing to Servicing and Maintenance  
By LOUIS MARTIN  
Automobile radios are up and coming, and someone has to service them properly. It therefore behooves you to read this immensely important new book on the art of Automobile Radio. The book is concise, and full of illustrations, photographs, diagrams and hookups.  
A few of the really interesting chapters: Introduction; Automotive Radio Installations; Complete Descriptions of Commercial Automotive Receivers; Servicing Automotive Receivers; The Ignition System; General Service Considerations; Effects of Temperature on Power Supply; Conclusion.

**Book No. 10**  
**Home Recording and All About It**  
A Complete Treatise on Instantaneous Recordings, Microphones, Recorders, Amplifiers, Commercial Machines, Servicing, etc.  
By GEORGE J. SALIBA  
If there is one subject that is fascinating to every radio man, it is that of Home Recording. Of course, this volume is not all on "Home" recording, but the information contained therein is important to commercial radio men, studio operators, engineers and others interested in this phase of radio.  
The art of recording and reproducing broadcast selections is becoming more important every day to radio men, experimenters and Service Men. Equipment, dance halls, auditoriums, churches, restaurants and homes with public address systems and amplifiers brings many extra dollars and often an excellent income.

**Book No. 11**  
**Point-to-Point Resistance Measurements**  
The Modern Method of Servicing Radio Receivers  
By CLIFFORD E. DENTON  
Of the difficult problems which Service Men face today when repairing receivers, the greatest is that of replacing proper resistance values in sets. This task becomes more difficult when the values of resistors are unknown; and manufacturers of many standard sets do not give this information to Service Men. In this new book radio men will find the information needed to quickly place a receiver in normal operating condition. This book cuts in half the time usually required to adjust the average set. Sufficient space has been devoted to the elementary problems and the theory of electricity as it is applied to resistance measurements so that the Service Man will have a comprehensive idea as to how to overcome this problem.  
Below you will find a partial list of the contents which will appear in this new book:  
INTRODUCTION. Advantages of Resistance Measurement Method of Servicing for Radio Work; Basic Principles; Methods of Resistance Measurement; Resistors in Radio Receivers and Amplifiers; Point-to-Point Resistance Measurements in Typical Radio Sets using Ohmmeter; Resistance Measurements using Modern Tester; Routine Testing where Circuit Diagram is Available and where Resistance Measurements are Unknown; the Relation of Voltage Testing Methods to Resistance Measurement; APPENDIX. Resistance Charts etc.

## ALL BOOKS UNIFORM

The books in the new RADIO-CRAFT LIBRARY are all strictly up-to-date, and written by men who know their subjects. The volumes are all uniform size, 6x9 inches, and contain on an average of 50 to 120 illustrations. Each book is printed on fine book paper and no expense has been spared to make it an outstanding value, for its editorial contents as well as from the mechanical standpoint.

## Clip Coupon and Mail Today!

GERNSBACK PUBLICATIONS, INC., 96-98 Park Place, New York, N. Y.  
I have circled below the numbers of books in the RADIO-CRAFT LIBRARY, which you are to send me, and have deducted 20% for ordering five (5) books or more. I have included my remittance in full, at the price of 50c each, when less than five books are ordered.

The amount of my remittance is.....(Stamps, checks or money orders accepted.)  
(Circle numbers wanted: 1 2 3 4 5 6 7 8 9 10 11

Name ..... Address .....

City ..... State ..... RC-4-34

## Big Discount to You

In order to make it possible for everyone to buy these books, the fifty (50) cent price has been made uniform for all volumes. You can buy these books separately, but you should take advantage of our special offer:

**When Five (5) Books or More Are Ordered**

**Deduct 20% from Your Remittance**

Simply fill in the coupon at left, and mail it to us together with your remittance. Checks, stamps or money orders accepted.



**"Takes the Resistance Out of Radio"**

Editorial Offices: 96-98 Park Place, New York, N. Y.

HUGO GERNSBACK, Editor

Vol. V., No. 10, April, 1934

## THE RADIO POWER WAR

An Editorial by HUGO GERNSBACK

**W**HEN RADIO broadcasting first got under way in 1921, practically all stations started with about 100 to 500 watts power, and for many years, this was standard. And this 500-watt maximum rating meant, of course, not 500 watts in the antenna, but merely the so-called "output" of the transmitter. Since the efficiency of broadcast stations was less at that time, the broadcast energy, therefore, was rather small—not much more than that of a good-sized electric incandescent lamp. Yet, with this little power, it was possible for us to rig up a one-tube regenerative set and listen to stations from all over the country. But soon all this started to change. Stations cropped up with 1,000 watts, and pretty soon we had especially "powerful" stations that used 5,000 watts. Then about 1928, we began to use so-called "super-power," of 50,000 watts or 50 kilowatts. Such stations as KDKA, WGY, WJZ, WEA, etc., were the first to use a power which, in those days, was considered colossal.

Let us stop for a second, at this point, and see why there was a demand for such power. In the first place, as stations became larger, as broadcasting became "big business," it was necessary to give the stations vast "coverage," of numbers of steady listeners. The engineer's idea, backed by the business management, was that anyone within a radius of 500 miles who had any kind of a radio set, of one tube or upwards, should be able to listen to these large stations. No one was to be left out, and every owner of any radio set must be able to listen to the program within a certain radius. Expensive advertising programs were put on the air, so naturally advertisers demanded "coverage"; and the broadcasters were there to fill the demand.

By and by, when it appeared that radio was a profitable business, many broadcasters wanted to use powerful stations. However, most of the applications were denied by the Federal Radio Commission because it feared chaos would result, and those stations which obviously did not give adequate public service were denied applications for super-power.

It was then found that you could circumvent such an edict of the Federal Radio Commission by moving out of the country. This is, indeed, what happened when a certain Texas broadcaster took his station and moved it across the border into Mexico, where he set up a transmitter with an output of 150,000 watts (150 kilowatts), which is now readily heard in many parts of the United States; and this in defiance of the Federal Radio Commission, which has no jurisdiction over Mexico.

As radio broadcasting advanced, and as more powerful equipment came to be designed, the broadcasters took another look into the future and said to themselves, "Why stop at 50,000 watts; why not 500,000 watts?" So thought Powel Crosley, Jr., owner of Station WLW in Cincinnati, favorably

located almost in the center of population of the U. S. He applied for a license for 500,000 watts, that is, 500 kilowatts, and got permission to erect the station and broadcast with this power. At the present time it is experimental only, broadcasting during the night hours. Soon, the station will be broadcasting during the daytime and, with the present power, it will be possible to lay down a signal that may be heard consistently over a radius of several thousand miles from Cincinnati.

In Europe, the situation is similar. The Soviet Government, which wishes to outshout and outdo all other broadcasters, now owns several stations which broadcast with a power of 100 kilowatts, and one of 500 kilowatts.

Little Luxembourg, with an area of about the same size as Rhode Island, helped itself to a choice wavelength and started a radio barrage across continental Europe with a "wattage" of 100,000—to the great discomfiture of the rest of the European nations, which are helpless to do anything because Luxembourg happens to be a sovereign state and is not much concerned with any radio laws promulgated at Berne.

From this, we see the trend of the times; and if anyone thinks that 500,000-watt power is as high as we can go, he does not reckon with either progress or with big business. That we will soon have 750,000 and even 3 million watts, no one today doubts. Rapidly, during the past ten years, the world has become radio-conscious. Boundaries and distances mean nothing. The world's population will listen to those stations which come in best, those which give the best programs, best music, and those which take the trouble to speak in the language of the people to whom the broadcast is addressed. Indeed, the Hitler government of Germany is making use of almost daily propaganda in English for North American consumption, and in Spanish for South American consumption.

Soon, our own broadcasters in America, as soon as their stations have stepped up to really great power, will find it necessary to send out programs in different languages, at different times of the day. At first, they will probably be in English, Spanish and Portuguese only; later on, our stations will cover Europe and Asia as well, and other languages must be added.

It is realized today that the use of radio broadcasting is not only for big business, but it is also political. During the past few years America has lagged in super-power, but soon we will be at the fore again, and it is to be hoped we will stay there in the battle of radio supremacy over the world. If our radio stations are directed properly, much good can be done—not only from the cultural angle, but in impressing other countries with American ideas and with American progress.



# THE RADIO MONTH



Photo by Bachrach

DR. J. H. MORECROFT  
Whose untimely demise is mourned by  
radio fans and engineers the world over.

## DR. MORECROFT SUCCUMBS AT PASADENA

A SAD outcome of the "game of the year" between Columbia and Stamford Universities on the first of January has become known during the past month. Dr. John Harold Morecroft, much admired and followed professor of electrical engineering at Columbia University and an internationally known figure for his research work in radio communication succumbed on Friday, January 26, 1934. Dr. Morecroft contracted pneumonia while watching the football game on New Year's Day.

Dr. Morecroft was born in England and was graduated from Syracuse University in 1904 and in 1906 he returned to Syracuse as instructor. In 1907 he became instructor at Pratt Institute and in 1909 he joined the Columbia faculty. During the war Dr. Morecroft was employed by the Navy Department to perfect a sound detector as a defense against submarines. He is known the world over for his engineering books on radio communication and recently has spent much time on development work in connection with vacuum tubes.

Dr. Morecroft had a pessimistic attitude toward television and was quoted as saying that few steps had been made in the past fifteen years. He said that

he could construct a set in his laboratory in a few hours that would give as good results as any now made, but that those results would not be worth the trouble and expense.

The demise of so famous and clever a man as Prof. J. H. Morecroft will be grieved by everyone acquainted with radio communication and electrical engineering.



Photo by Soy Uzbhoto

THE STRATOSPHERE FLIGHT THAT FAILED  
This view shows an engineer installing  
the Soviet stratosphere balloon's aerial.

## STRATOSPHERE FLIERS' DEATH NO FAULT OF RADIO EQUIPMENT

THE tragic death of the three Soviet airmen who flew higher than man has ever before achieved brought to an end a long heralded flight from Moscow recently.

The balloon was built with the greatest possible precision and was fully equipped with radio transmitting and receiving equipment. The radio installation worked perfectly throughout the flight, and even a few minutes before the crash; 150 miles from Moscow, listeners heard that "all was well."

The three men who lost their lives were Paul Fedeseemko, the commander of the balloon, who was a well-known

civilian pilot; Ilya Oususkin of the Institute of Physical Science—the vice commander, and Andréy Vasenko, the constructor of the balloon.

Despite the unfortunate ending of this flight, the usefulness of radio for such uses is evident. Without radio, it would not have even been known how high the fliers went, or where they were before they crashed. Not that the latter could have possibly forestalled the unfortunate accident, but at least it helped locate them immediately afterward.

## AMATEUR RESCUES FLIERS LOST IN CANADA

ONCE more we must take our hats off to amateur transmitters as a reliable rescue force. The many thrilling acts of amateurs in the past are known to everyone. The many floods, earthquakes and other calamities at which they have served are too numerous to mention.

The latest addition to the "honor" roll is Arthur Ozvath of White Plains, New York, who picked up a message which resulted in the location of four fliers forced down in Northern Canada, and from whom no word had been received for almost a month.

The message received was as follows: "We are down safely in Port Harrison. Send word to Canadian Airways." It was signed Dick Bibby.

Arthur, who operates amateur station W2CSM succeeded in making contact with the Canadian Airways and a plane was sent to the men. The four men were found safe and unharmed.



THANKS TO W2CSM  
Four fliers who were forced down in  
northern Canada were found safe and  
unharmed.



# IN REVIEW

Radio is now such a vast and diversified art it becomes necessary to make a general survey of important monthly developments. RADIO-CRAFT analyzes these developments and presents a review of those items which interest all.

## RADIO TAXIS BANNED—THEN PERMITTED

**S**INCE our first mention of the influx of radio-equipped taxicabs in New York City, a very interesting controversy has been going on. First, former Police Commissioner Bolan apparently regretted his decision to permit the use of radio receiving sets in cabs. After the first few thousand "radio" taxis had been placed on the streets, and a wide interest was shown by the public, as mentioned in RADIO-CRAFT, February 1934, page 455, friend Bolan retracted his ruling. The date of the ban was delayed, to give General O'Ryan, the newly appointed Police Commissioner, a chance to pass on the matter.

Commissioner O'Ryan said: "I believe the Commissioner's duty under the law is limited to the effect of the use of radios upon the safety of operation of the vehicles in which they are installed and particularly whether the inclusion of a radio set as part of the equipment of a licensed taxi renders such a vehicle unfit or unsuited for public patronage."

It is interesting to note that news has also been received that taxi companies are now experimenting with a switch arrangement in conjunction with the rear seat cushion. When the passenger sits down, he automatically closes the switch, disconnection being made when he rises again.

With reference to Commissioner O'Ryan's decision, we wonder if the taxi drivers' attention will be concentrated on driving when an interesting or amusing program is being received by the passenger!

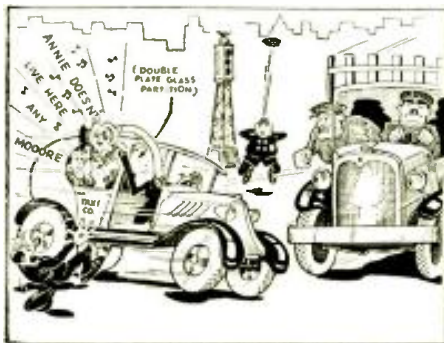

NEW YORK'S RADIO TAXIS

Will the drivers give their attention to driving under the conditions shown in this sketch?

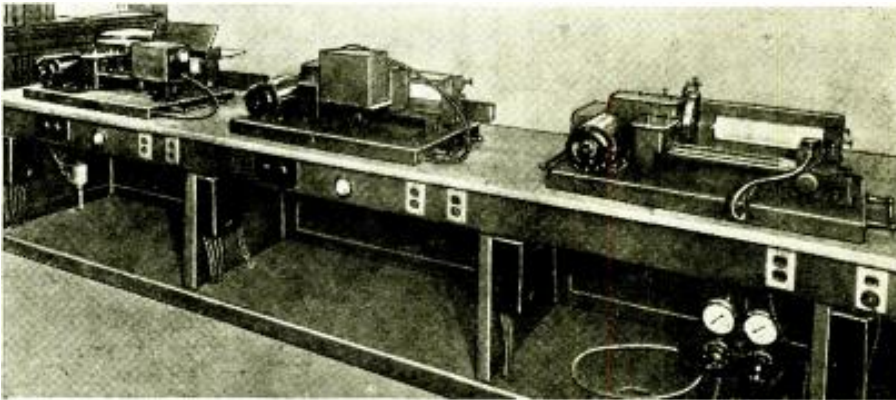

Photo by RCA.

### ULTRA-SHORT-WAVE FACSIMILE TRANSMISSION

While the units shown are used in transatlantic communication, similar units will be used for ultra-short-wave facsimile transmission between New York and Philadelphia.

## ULTRA-SHORT-WAVE PHOTOGRAM SERVICE

**R**ADIO Corporation of America has just announced that they are preparing to supply a service of radio picture transmission on ultra-short waves between the large cities of the United States, by a method similar to the transatlantic facsimile transmission pointed out by Hugo Gernsback—"Radio Set Delivers Newspaper"—in this issue.

In fact, they are actually in the process of constructing the first of a chain of such transmitters which will provide service between New York and Philadelphia.

While facsimile transmission is not entirely new, being in commercial use for transatlantic service at this time, this is the first indication of the use of ultra-short waves and shows to what extent these wavelengths will be in demand in the near future, for short-distance communication of all types.

The system under construction will utilize two automatic relay stations at New Brunswick and Trenton, New Jersey. These relay stations will boost the strength of signals so that constant service can be guaranteed.

In commenting about the new system, David Sarnoff, President of RCA said: "Over this new circuit, when completed, it is confidently expected that photograms will be transmitted at higher speed and at lower tariffs than is possible with the dot and dash system of

the morse code. Tariffs on this circuit will not be based upon so much per word but upon so much per square inch, or perhaps so much per standard size letterhead."

## THE HYPNOTONE — A NEW RADIO INVENTION

**A**RE you troubled by lack of sleep at night? Does the baby keep you awake? Well, then here's news that will interest you!

It is a new device developed by Hugo Gernsback and fully described in the April, 1934, issue of EVERYDAY SCIENCE AND MECHANICS, which induces sleep even when other methods fail.

Insomniacs may eventually disappear—their malady entirely cured.

How does it work? Well, that's easily

(Continued on page 619)



THE HYPNOTONE

Does the baby keep you awake at night? Here is just the device that you need, then.



# RADIO PICTORIAL

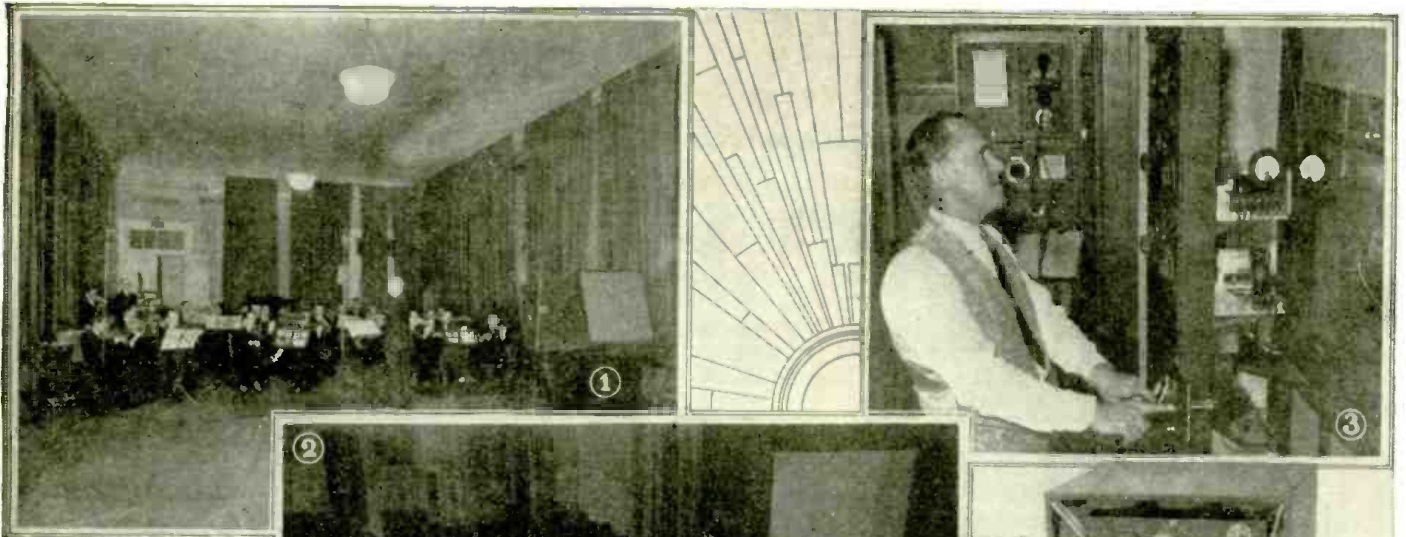

A new era in motion picture sound reproduction may be inaugurated soon, according to experiments by Bell Telephone Laboratories, on "third dimension" sound.

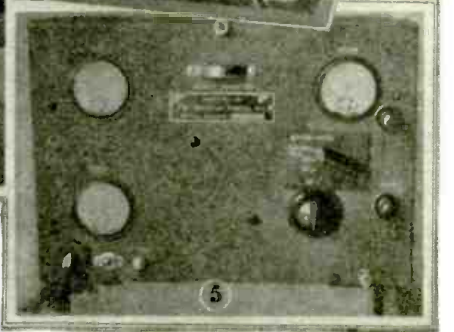

On the right (4 and 5) are shown the transmitter and receiver which Colonel Lindbergh carried on his recent flight. The left photo (6) illustrates an innovation in the method and equipment employed for obtaining a permanent wave—in one beauty parlor.



AN inkling of the music of the near future, and incidentally, the introduction of "realism" in the sound reproduction of motion pictures, was given in a demonstration at the Engineering Societies' Building, New York City, by the Bell Telephone Laboratories. A small orchestra of thirty pieces (shown at 1) was amplified to sound like 5,000 musicians, and an ordinary buzzer was made to sound like a thousand boiler factories. Airplanes flew from the stage and over the heads of the audience—that is, the sound effects were so realistic that the impression of the audience was that the planes were flying above them. A revolver shot could be heard whistling across the stage, and then to climax the amazement of the audience, the shot was made to reverse itself and return to the place it started from. In the second photo are shown the controls for obtaining these weird effects, in addition to the signalling booth, amplifier room, etc., etc., so as to maintain the proper coordination necessary for these effects. Separate microphones, as shown in the first illustration, connect to individual amplifiers, and, in turn, connect to their respective loudspeakers on the stage.

A new ultra-short-wave radio for controlling airway beacons is shown in the third photograph. The remote control transmitter shown operates on a wavelength of about five meters, and in operation the radioman simply dials a series of pre-determined characters, like making a telephone call, and the short-wave impulses operate the radio beacon without the guidance of a human hand.

When Colonel and Mrs. Lindbergh made their recent 30,000 mile flight around the Atlantic, the radio flashes sent by Mrs. Lindbergh, who performed the services of radio operator, aroused considerable newspaper comment concerning her proficiency in this direction. The transmitter and receiver employed, and pictured in 4 and 5, were built in a water-tight case to survive a crash, submersion, arctic cold or equatorial heat.

It may soon be possible to obtain a "permanent" via radio—(this to the ladies) and the mechanism which suggests this possibility is shown in the sixth illustration. Because of this arrangement it may be soon found that the housewife can go about her tasks, get her permanent, and listen to her favorite program, all at the same time.

(Continued on page 632)



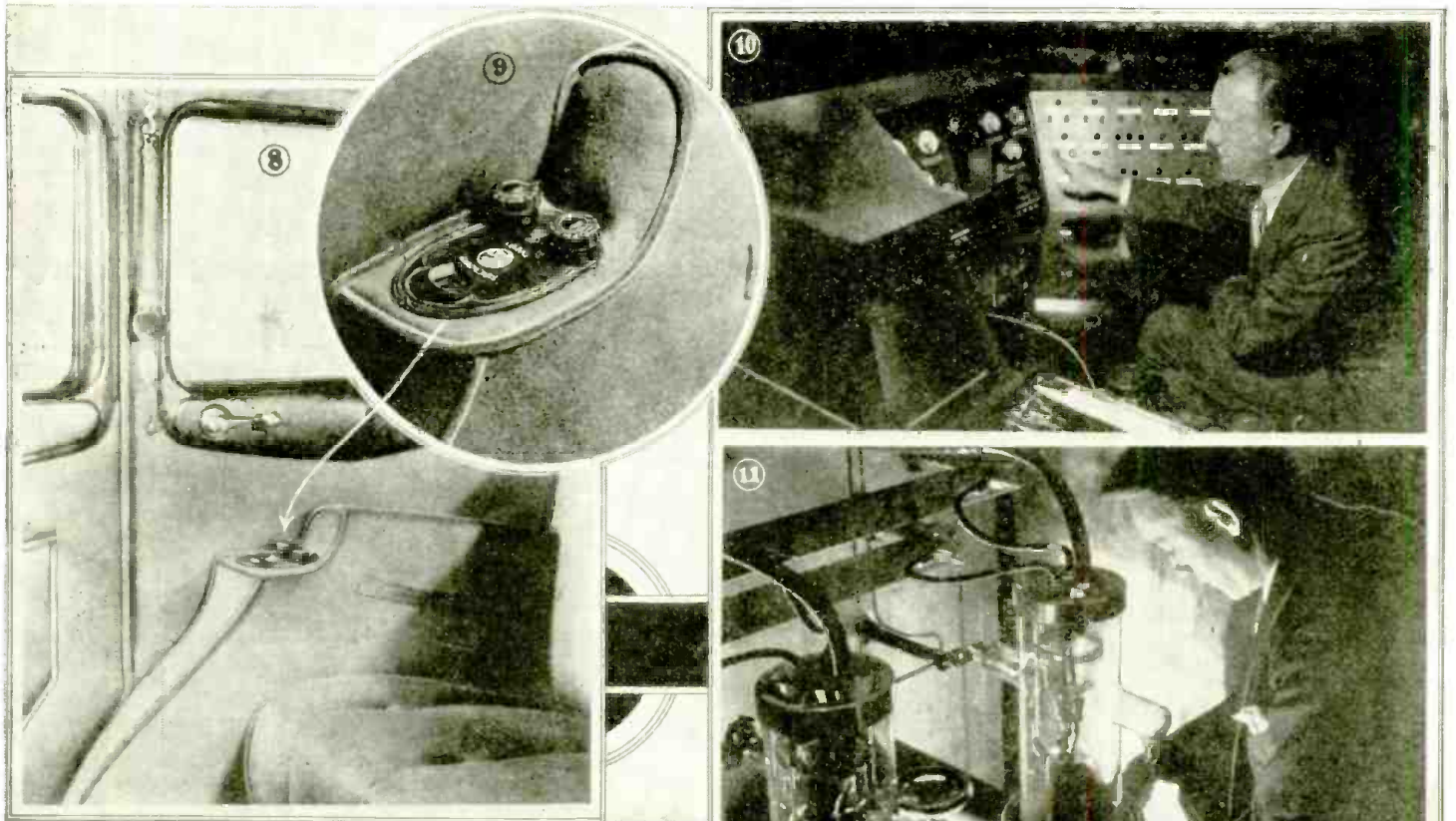

HERE'S the radio control that tunes the set in the auto of the President of the United States. And, if we may be permitted to say so, it sure is a neat and convenient installation. Judging from the photographs (numbers 8 and 9), if the same amount of attention was given to other installation details, the reception should be very satisfactory to the President.

And here we have the new giant 500-KW going on the air for the first time (10), the gentleman pressing the button, in this illustration, being none other than Mr. Powell Crosley, Jr., the owner of the station. At 11 we see just a few of the 20 giant water cooled tubes used in this new 500,000 W. station.

Did you ever have trouble in making yourself heard over the telephone? Well, the Bell Telephone Laboratories which performs all sorts of telephone research has perfected an "artificial mouth" (12 and 13) to conduct tests to indicate the causes of such trouble.

The ticking of small watches are often very hard to detect. And because, many times, the watchmaker can only tell by this sound if the watch is operating correctly or not, a correct analysis of watch ailments is sometimes impossible. Only recently, the Bell Telephone Laboratories have developed a method whereby such feeble impulses may be amplified and thus facilitate repair. Photographs 14 and 15 show the mechanism and amplifier employed. The metal case of the watch is made to act as one plate of a condenser. The plates of this condenser are charged by a battery placed across them and through a high resistance. Also, the two plates are connected to the input terminals of an amplifier, and thus the resulting fluctuations are magnified by the amplifier which is of high-gain type.

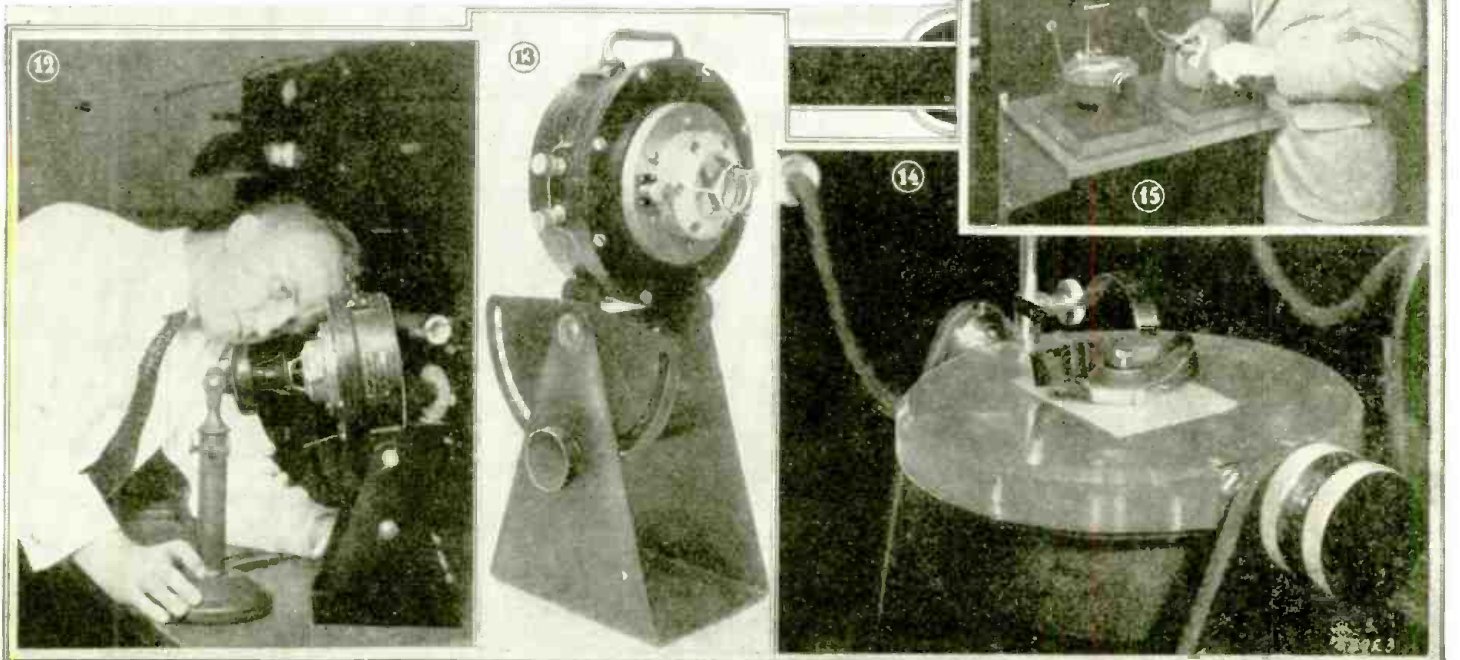



# THE LATEST RADIO EQUIPMENT



"Best-selling" bypass condensers. (No. 422)

## "REPLACEMENT" CONDENSER KIT

IN line with the present "replacement" idea, which is to furnish components of identical characteristics but independent manufacture, and the "kit" idea, of supplying units of assorted values, there has been marketed the kit of replacement condensers illustrated above. These 50 condensers, of "mid-geet" type, are "outside foil grounded." Capacity values are from 250 mmf. to .5-mf. (600 to 400 V., working).

## NEW "FLOOR"-TYPE MICROPHONE

A NEW design in microphones is illustrated in the figure below. This "piezoelectric" microphone is designed to set directly on the floor (as, for instance, in a theatre stage); excellent for producing "binaural" effects (by using several of these units).

The output is to be fed into a standard 2 stage pre-amplifier. The floor acts as a baffle, enhancing the low-frequency response; wide-range pickup is obtained.

This microphone establishes a new standard for units of this type, first described in the July, 1932, issue of RADIO-CRAFT, in, "The Rochelle-Salt Crystal Reproducer."

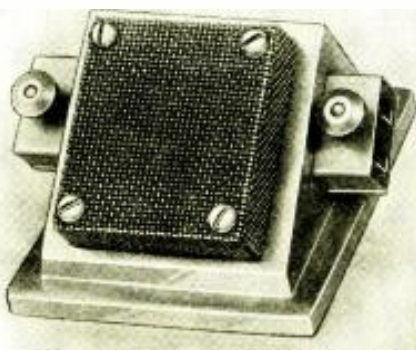

"Don't tread on me," says "mike," for, this "low down" microphone mounts on the floor. (No. 423)



All-wave service oscillator. (No. 424)

## "ALL-WAVE" SERVICE OSCILLATOR

IN the figures above and below are illustrated a service oscillator that was designed to meet the need for an instrument to cover a frequency range of 150 to 25,000 kc. (2,000 to 12 meters, approx., respectively).

The device requires two type 30 tubes, a 4.5 V. "A" battery, and a 22.5 V. "B" unit. These are contained inside the aluminum shield case, which measures 9 3/4 x 4 1/2 x 8 1/2 ins. high; the weight, with batteries, is 3 1/2 lbs. The light weight is a welcome feature.

A 7 point switch controls the frequency ranges, which are as follows: 150-330 kc.; 330-720; 720-1,460; 1,460-3,505; 3,505-7,400; 7,400-14,300; 14,300-25,000. The vernier tuning ratio may be varied from 6-to-1 to 20-to-1 by adjustment of the position of the small arm above the tuning knob; the position for maximum vernier action is very useful where tuning is critical.

One tube is the R.F. oscillator; the other, its 400 cycle modulator.



Above, rear view of all-wave oscillator. Right, a 1934 car radio set. The left-hand control knob is entirely removable. (No. 426)

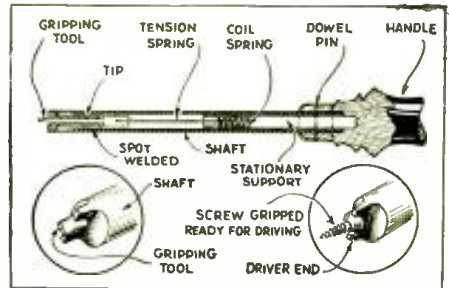

A Service Man's screwdriver. (No. 425)

## A RADIO SCREWDRIVER

FOR a long time radio men have needed a few special tools. It is of interest, therefore, to note that one manufacturer is now offering a chrome vanadium steel screwdriver, illustrated above, that fulfills some of the demands of Service Men. The unit is made of high-grade materials, and should give good service.

This tool is available in lengths of 3 to 10 ins. Its feature is a central, rotating section of the blade: this section presses firmly against the screw slot and holds the screw until its thread has a chance to catch hold.

## A NEW CAR RADIO SET

A 6 tube set of modern design is illustrated below. It incorporates two type 78 tubes, a 75, a 6A7, a 41 output tube and, in the "B" unit, a type 84 rectifier.

This set is entirely self-contained. Note that the new "airplane"-type dial is used in the remote control unit. The field coil of the dynamic reproducer obtains field current from the storage battery of the car.

(Continued on page 619)



Name of manufacturer of any device will be sent on receipt of a self-addressed, stamped envelope. Kindly give number in description under picture.





Shielded fuse retainer. (No. 427)

### AUTO-RADIO FUSE RETAINER

**A**LTHOUGH the device illustrated above was designed especially for use as a fuse retainer, it also may be used as a connector unit—especially, for connecting the flexible lead from the antenna connection of the car radio set, to the antenna lead-in. Previous types of “retainers” were unshielded.

Used as a fuse retainer, it takes the standard type 3-AG automotive fuse. The retainer hangs directly in the “hot” side of the “A” line, leading to the car radio set. The retainer takes auto cable up to 5/32-in. in dia.; the shielding, where necessary, can be attached to the retainer. Fuse renewals are made by turning a small bayonet lock.

When used as an antenna connection, the fuse is omitted, and the contact buttons are placed directly together instead of at the fuse ends. Contact is maintained by a strong spring.



Tube-Gripping Shield. (No. 428)

### SNUG-FITTING TUBE SHIELDS

**S**ERVICE MEN should find the tube shield illustrated above a profitable item to carry as a “side” line. This tube shield design differs from previous types in that it has a series of vertical depressions that, on the inside of the shield, form ridges which grip the tube tightly. This design serves two purposes.

First, it prevents the glass bulb from vibrating, and thus reduces the tendency to cause microphonic noises. Secondly, it prevents injury to the tube, and prevents it from loosening in the socket.

These shields are available in sizes to fit standard tube types.

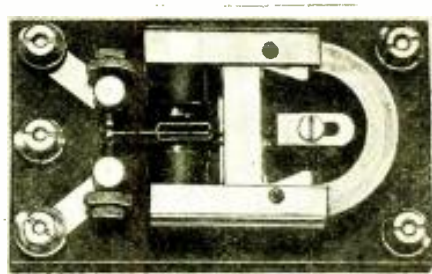

High-Resistance Relay. (No. 429)

### 6,000 OHM POLARIZED RELAY

**A**BOVE is illustrated a new relay designed to break 2 A. at 110 V., A.C., or 0.25-A. at 115 V., D.C., non-inductive load. An auxiliary relay will not be required in most cases.

These relays can be furnished with total coil resistance up to 6,000 ohms (approx.), and satisfactory operation can be secured with power consumption as low as .01-W., D.C.

The parts are mounted on an insulating base which measures 5 x 3 x 1/2-in. thick; the overall depth is 2 1/2 ins., including the base.

This relay is designed for operation where the D.C. in the operating coils must be kept as low as possible, and where reversal of the current in them brings about a reversal in the contact arrangement, but where no contact is made when the coils are de-energized.

# DON'T "FIGHT," BUT SHAKE HANDS WITH YOUR SERVICE OSCILLATOR

KENDALL CLOUGH\*

**T**HERE exists among Service Men widespread ignorance of the capabilities of the common, or “garden” variety of service oscillator—and even more regarding the newer, and vastly more efficient models that have made their appearance within the last year.

An outstanding example of the newest in service oscillators is illustrated in actual operation, in Fig. A. Strange it may be, but nevertheless true that the average Service Man would seldom attempt to use this instrument in the manner shown in the view, that is, to check the A.V.C. action in a receiver under suspicion. Perhaps if we point out the ease and speed with which many tests in radio receiver circuits may be made, the technician will be less inclined to “fight” his best tool—and will, instead, endeavor to master its many functions.

Included among the accomplishments of the latest design in service oscillators are the following:

- (1) Aligning R.F. circuits;
- (2) Aligning I.F. circuits for either “flat top” or “peak” resonance;
- (3) Aligning oscillator circuits;
- (4) Trimming oscillator padding condensers;
- (5) Checking tube efficiency;
- (6) Determining overall receiver gain;
- (7) Testing A.V.C. circuit operation;

- (8) Making stage analyses;
- (9) Checking overall receiver selectivity;
- (10) Neutralizing receivers incorporating any type of neutralization circuit;

(Continued on page 632)

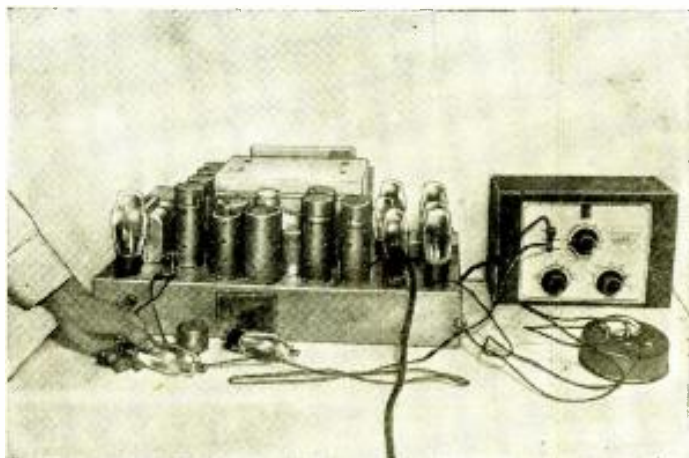

Fig. A

Meet Mr. Service Oscillator, “on the job.”

\* Chief Engineer, The Clough-Brengle Co.

# INTERNATIONAL RADIO REVIEW

## AUTO RECEIVER FROM ENGLAND

IN RECENT issues of the various English radio magazines, much interest has been displayed concerning the automobile receivers which have made their appearance. While these sets follow the general appearance and construction of American sets, there are certain fundamental differences imposed by the broadcasting conditions in Europe.

The set shown in Fig. A, is a typical set which was described recently in WIRELESS WORLD. The first thing of interest about this set that is noticeably different from American sets is that it consists of two units—the receiver and the speaker. Thus, it resembles the sets shown in this country a year or more ago. Also, an examination of the description in WIRELESS WORLD reveals the fact that the set is completely battery operated, the filament supply being taken from the car battery, while the "B" supply is taken from "B" batteries which are housed in a third box mounted under the floor of the car. In these respects, the set is behind the present designs of auto sets manufactured in the U. S.

However, in other respects it is quite modern. It has a T.R.F. circuit, using variable mu tubes, diode detection, A.V.C. and class B A.F. amplification. As we have pointed out several times, the latter A.F. method is exceptionally popular in England, at this time.

The set covers not only the regular broadcast band, but also the long-wave bands used by European broadcasters. The shifting from one band to the other is accomplished in the remote control unit, by the use of a relay actuated by the on-off switch. Two tuning scales appear at the dial window, illuminated in different colors for the two bands. Iron core R.F. tuning coils are used in the set (these coils have been discussed in this department in recent issues).

HERE is what the radio experimenter has been wanting for a long time—a semi-technical review of the thousands of new ideas which are continually appearing in overseas publications. Each month there are received at the offices of RADIO-CRAFT hundreds of daily, weekly and monthly magazines originating from every point on the face of the globe.

SINCE the cost of subscribing to each of these would be prohibitive for most radio men, we have arranged with technical translators to prepare for our readers reviews of all the really important, new developments illustrated and described each month in these international radio periodicals.

NOTE that the only available information is that which is published; the experimenter must adapt the ideas to whatever equipment he has on hand.

## GLOW-TUBE VOLTAGE DIVIDER

IN THE ordinary type of "B" power unit found in A.C. sets, the voltage supplied to the various tube elements varies according to the current taken by the amplifier tubes. As the load increases the voltages on the plates and screen-grids drop off. This effect occurs, even when a transformer with good regulation is used, because of the increased potential drop through the rectifier and filter.

To obviate this difficulty, the system shown in Fig. 1 has been developed. This unit was described in THE BROADCASTER AND WIRELESS RETAILER.

It consists of a gas-filled tube having constant voltage characteristics—that is to say, instead of following Ohm's law it can take an increase in current without producing any change in the applied voltage. This is caused by the varying resistance characteristic of the glow-tube used. This tube is a development of the Marconi Company.

## SHORT-WAVE IRON CORE COIL

IN RECENT issues of RADIO-CRAFT, we have pointed out that radio experimenters in Europe are becoming interested in R.F. tuning coils having various types of iron cores. It is claimed that the iron core increases the effective "Q" of the coil (the "Q" of a coil is the term applied by engineers to denote the efficiency; it is the ratio of the reactance to R.F. resistance of the coil.—Assoc. Editor) and at the same time limits the external field, so that interstage coupling is not a serious consideration even with high-gain tubes.

Up to this time, however, these coils have been limited to the broadcast band and the long waves used in Europe for broadcasting purposes. The coil shown in Fig. B is made in several different types, one of which covers the wave band from 13.8 to 78 meters (in two sections). This is an innovation, as it permits experimentation with these new coils on the higher frequencies which should produce fine results if the claims for these coils are correct. The knob of the coil shown is a switch to permit changing from one band to the other.

We are awaiting with interest the results of several rumors to the effect that American coil manufacturers are working on variations of the iron core R.F. and I.F. coupling coils. Experimenters will, no doubt, be anxious to try these new coils which are making such a hit abroad.

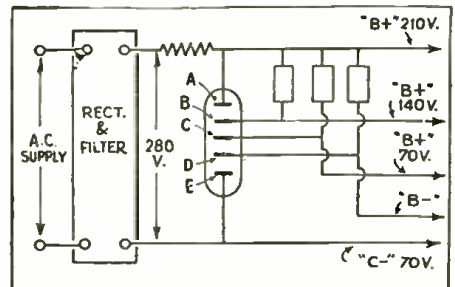
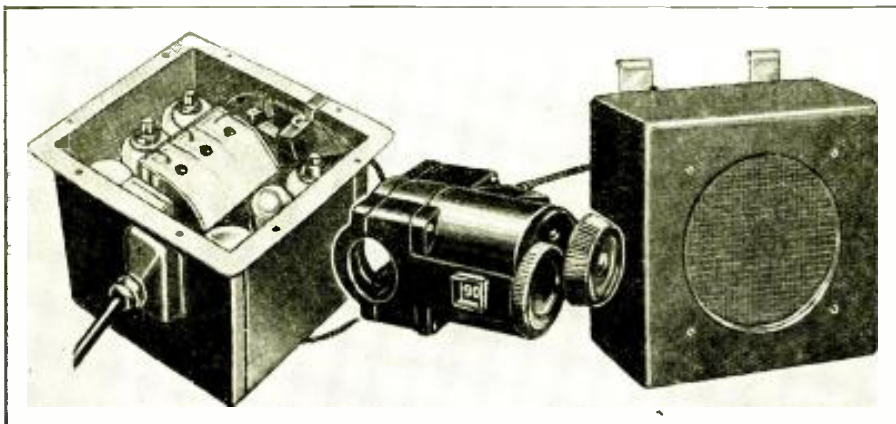

Fig. A, left  
The appearance of the English auto set.

Fig. 1, above  
A glow-tube voltage divider or bleeder.



## VOLUME CONTROL FOR BATTERY SETS

THE rejuvenation of interest in battery sets using the 2V. series of tubes with constant-potential primary batteries, opens up another field of experimentation for the radio set constructor and Service Man.

In a recent issue of WIRELESS WORLD, a novel system of obtaining volume control in battery sets using variable mu tubes was shown. The circuit is shown in Fig. 2. As you can see, it consists of a combination of "C" bias control and aerial-shunt volume control. This system has been used to advantage in A.C. sets in which the bias is obtained from a cathode resistor. However, this method is not very satisfactory for battery operation and it is usual practice to employ separate "C" batteries.

In order that the sensitivity may not be affected noticeably at the maximum position of the volume control, an R.F. choke must be inserted as shown, and also the grid decoupling resistor R1 must be of high value—about 50,000 ohms, in place of the more usual 5,000 ohms. Also, to prevent short-circuiting the "C" battery in the minimum position of the volume control, a fixed condenser C1, must be inserted in the aerial lead, .001-mf. will be satisfactory.

## ADJUSTABLE SPEAKER IMPEDANCE

THE difficulty of matching a speaker to the various output tube impedances has been met very satisfactorily in Europe by the speaker shown in Fig. C. This speaker is a permanent magnet dynamic unit in which the output transformer is equipped with a tapping scheme, thus permitting taps to be taken at the correct points to match the various tubes in use. The manufacturer shows how 17 different output impedance arrangements can be obtained with the double switch, and in addition four ratios are available for push-pull circuits.

A slightly different speaker to the one shown is advertised especially for extension or remote speaker use. This speaker is equipped with a separate volume control and an on-off switch so that it may be completely controlled from the remote point.

While there may be some loss in the unused portions of the matching transformer, this system is particularly useful for the experimenter and the loss should not be sufficient to be noticeable in the quality or volume of output.

## A NOVEL TUNING METER

THE FRENCH radio magazine, RADIO REVUE, recently contained details of the construction of an unusual type of tuning meter that the home set builder can make. As shown in Fig. 3, it consists of a milliammeter connected in the cathode circuit of one of the R.F. tubes of the set. The indicating needle is equipped with a light shutter and a small pilot light is focused onto the flat plane of the shutter. When the set is turned on, the indicating needle of the meter moves to the maximum position

showing maximum plate current flowing. Then as a signal is tuned in, the plate current falls off somewhat and the shutter blocks out less of the light of the pilot lamp.

A ground glass or translucent celluloid screen on the panel of the set, placed in the plane of the lamp and shutter will indicate to the operator the point of exact resonance by the width of the dark shadow on the screen.

The screen can be mounted over the dial of the receiver so that the tuning meter is in a convenient position. By adjusting the sensitivity of the meter by the use of shunts, the indicating needle can be made to move over the desired arc.

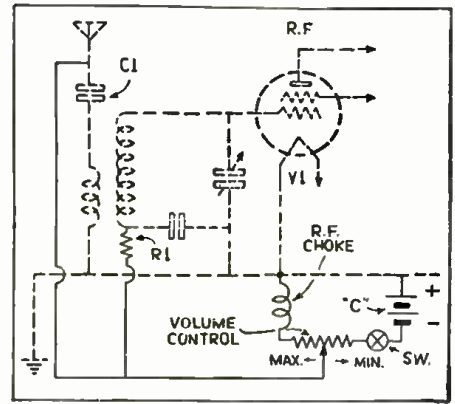

Fig. 2  
A volume control method for battery sets.

## AUTOMATIC RECORD PLAYER

RADIO and phonograph enthusiasts in England can now enjoy phonograph music without the nuisance of setting the record, turning on the motor and dropping the pickup in the correct groove of the record. By the use of the device shown in Fig. D, playing a record becomes as simple as dropping a letter in the mail box.

Records of any size are inserted in the "letterbox" slot. This switches on the current and sets the pickup. When finished playing, the current is switched off and the record automatically returned. These units are available for various voltages and frequencies of A.C. The unit consumes about 20 W. of power.

## RECORDING SOUND HEAD

THE unit pictured in Fig. E is a device available to the home-recording enthusiast in Austria. It appeared in RADIO-AMATEUR magazine.

It is a device for simplifying the task of cutting records at home. As you can see it consists of a cutting head, mounted on a horizontal frame, the end of which is connected by a flexible coupling to the central pin of the record turntable. By the use of this device, the motion of the cutting head across the record blank is caused by the motion of the flexible drive which is actuated by the actual movement of the turntable. This eliminates the need for synchronizing the speed of the record with the mechanism moving the cutting head.

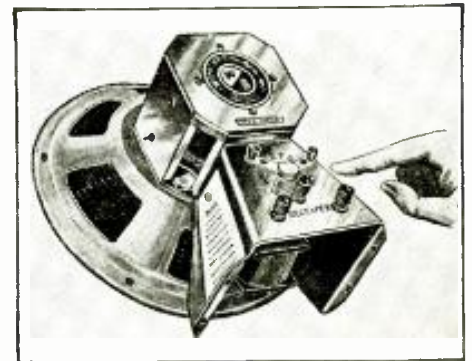

Fig. C  
This speaker can be matched to tube impedance.

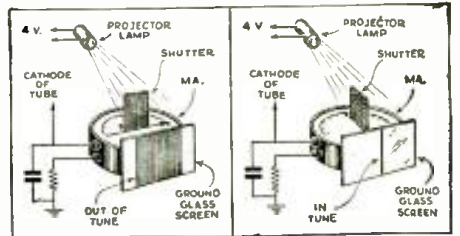

Fig. 3  
A tuning meter kink for the experimenter.

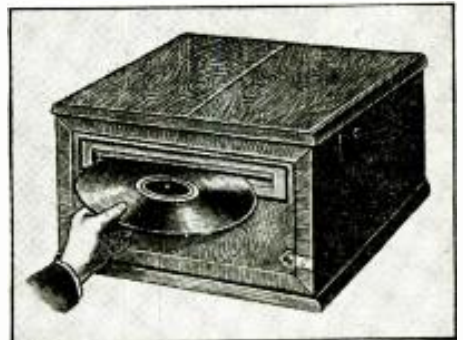

Fig. D  
A completely automatic phono. record player.

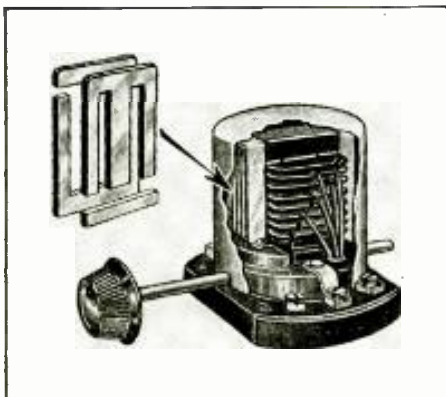

Fig. B  
The iron core coil for short waves.

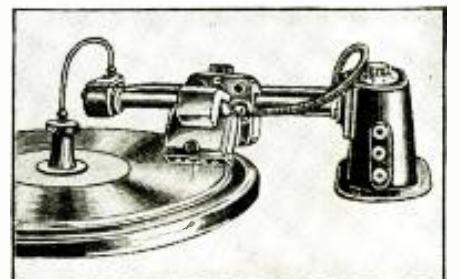
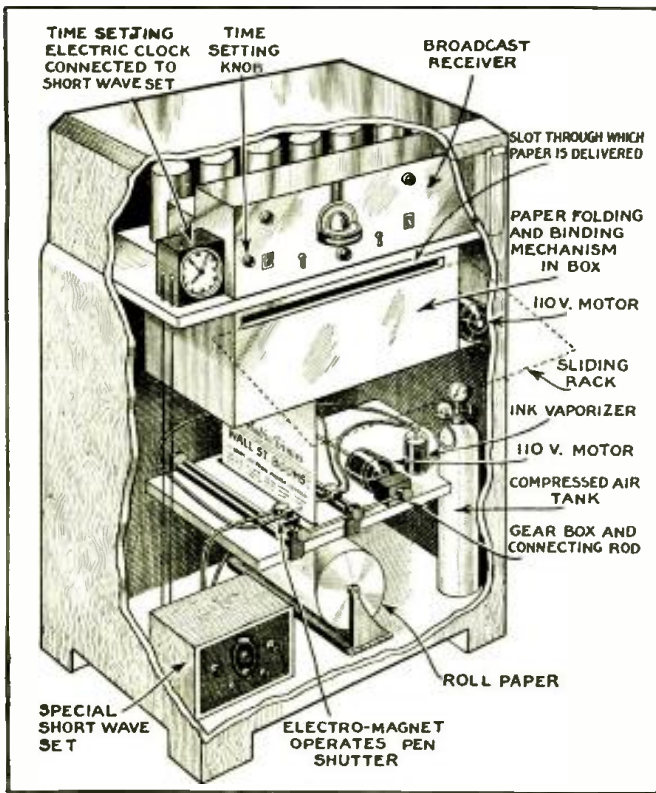

Fig. E  
An Austrian cutting head for home recording.

# RADIO SET

There can be no question that the future of radio holds forth the best and most promising inventions — and, amongst those that will probably be seen in the not too far off future—will be a complete newspaper received and printed by the radio receiver, with illustrations, text, and probably advertising. It is even possible to construct such a set now, since equipment in present use for facsimile picture transmission may be readily adapted for a "radio newspaper" unit. These methods and associated equipment and their adaptation are described in this article.



**A**S I have frequently observed—the great radio inventions are still to come. So far, the proverbial surface has not been scratched. As the radio technique advances, and we obtain better instrumentalities, it becomes possible to do a lot of things which have not even been dreamt of before.

The radio set of the future has been envisioned many times, but not even the most audacious thinkers, who have projected themselves into the future, have imagined the final radio set—if indeed there is to be such a thing as a final radio set in the dim and distant future.

There has been, ever since the advent of radio, a feud between radio broadcasters and the newspapers. Originally, newspapers gave radio a tremendous amount of publicity; but, of late, the newspapers have felt that radio has become their greatest competitor. Consequently, they have cut down a good deal on the space allotted to programs until in many cities, particularly in the Middle West, no free programs are printed at all in the newspapers. These newspapers argue that this is free publicity and, if you wish to have your program printed, the station must pay for it. In-

deed, in some of the Middle Western and Southwestern states, this system is now in vogue and the radio stations are indeed paying for their programs.

Recently, a new step was undertaken by the Columbia Broadcasting network to checkmate the newspapers; and Columbia now has its own newsgathering service which extends nationwide and abroad. Every night, a news service is put on the air; the information is, frankly, only "spot" or early, incomplete news; and the network is careful always to have a "by-line" which is as follows: "See tomorrow's paper for complete news." It is believed that in the future the rift between newspapers and radio broadcasters will widen.

The idea of using your radio set in your own home, to print a complete tabloid newspaper and deliver it to you, is not original with me. The idea has been mentioned by many well-known radio engineers ever since 1925, and perhaps even before that. There is, therefore, nothing novel in the idea itself; but the project so far, has not been translated into actuality. From the technical standpoint, it is perfectly possible to build, today, a radio set, for use in your own

home, which will deliver to you, early in the morning, a small newspaper, and do this regularly, every day in the week. So far, the only drawback has been, in my estimation, the price. Such a set is expensive to build, and somewhat complicated and costly. If, however, the country wants a *Radio-Newspaper Receiving Set*, the radio industry is, no doubt, in a position to furnish such a set on short order. Indeed, I will be considerably surprised if such sets are not on the market within the next five years.

While none of these sets have, as yet, been built, I have outlined in these pages the technical details of bringing it about; and, though the system which I show here may not be the only practical one, I have selected it because a similar method is now in use by the Radio Corporation of America in their picture-transmitting devices which are in operation twenty-four hours a day throughout the week.

Let us now see what the future radio newspaper set will look like:

As our cover illustration shows, it seems very much like any other radio set, but with certain attachments. These are, chiefly, a panel which pulls out, and



A recorder employed by RCA Communications for picture facsimile reception.

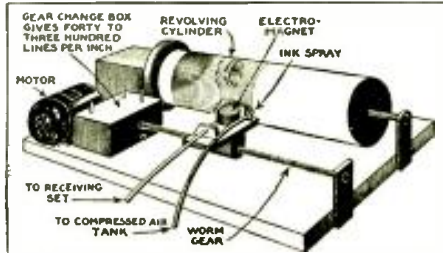

The same unit as shown on the left, but in schematic form with explanations of operation.

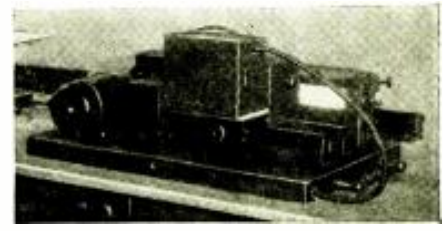

A scanning unit used in the transmission of photographs, by RCA.



# PRINTS NEWSPAPER

HUGO GERNSBACK

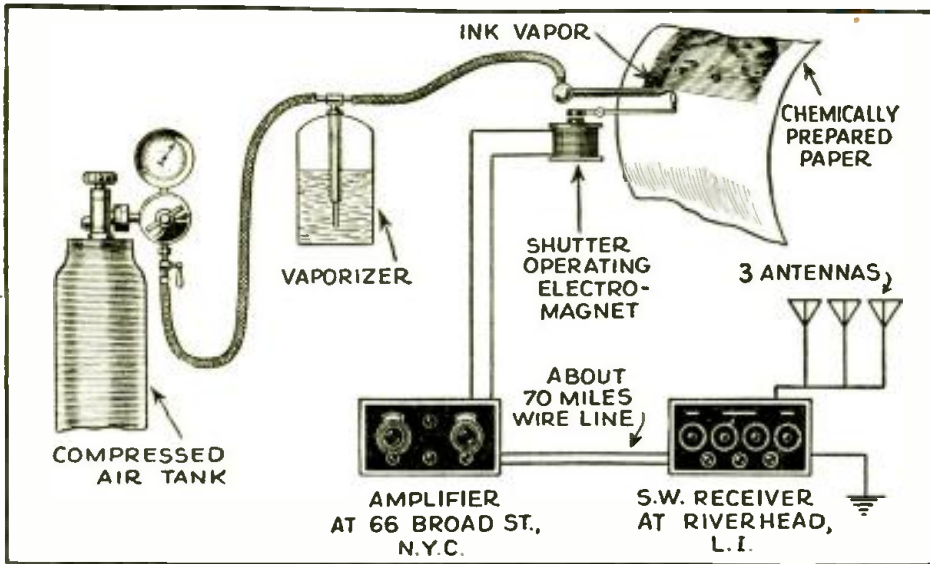

An ink-pen arrangement that was employed some time ago, but discarded in favor of improved methods.

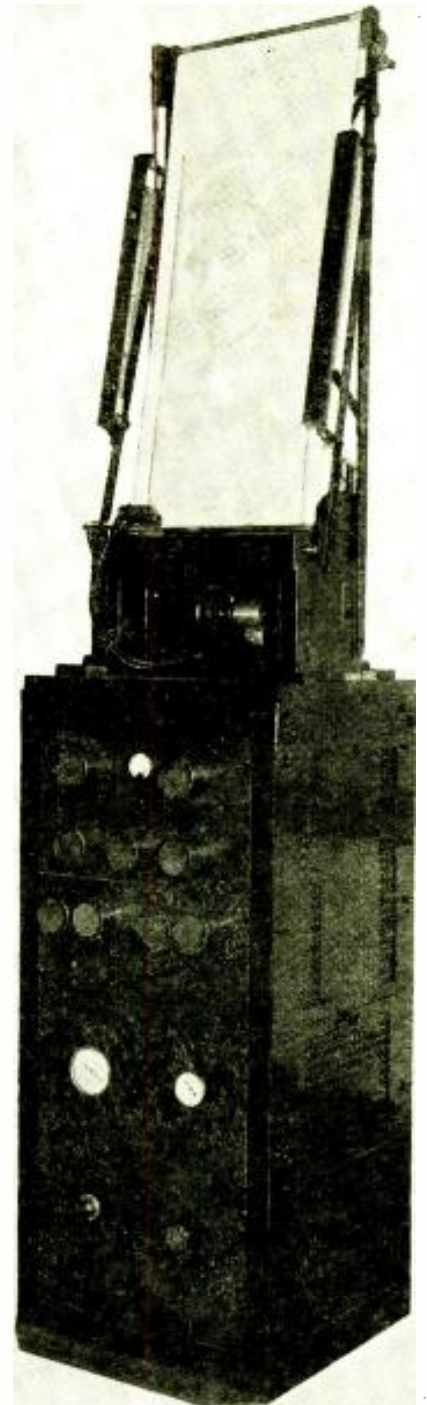

A complete RCA facsimile receiver used at the Chicago World's Fair in 1933.

upon which, in the rack provided, you will find a newspaper ready and printed in the morning. Remember, too, this will not be a bulky 64-page newspaper! it will be, probably, a 4- or 8-page tabloid, giving you condensed news and pictures of the important events, similar to that shown in the cover illustration.

The cabinet contains the usual broadcast and short-wave set, as we have them today. In addition to this, there is a separate special short-wave set, to take care of the reception of the news, and which will be described later. The set also contains a clock which is set for, let us say, 2 A.M. At this time, the clock disconnects the broadcast set from its aerial and ground and in its stead, switches on the special short-wave set; and, at the same moment, the electric motor (which has to do most of the work in printing the newspaper) is also placed into the circuit. A few seconds later the radio signal impulses begin to

come over the special short-wave set, and the newspaper is now being "printed."

In the particular method which is shown here, for the first time, there is no "printing" being done as we know "letterpress" printing today; it is all done by a special method, both sides of the paper being acted upon at the same time. I will explain details further on.

The electric motor, which feeds the newspaper roll, advances the roll little by little until, in an hour or less, the entire newspaper is printed. When it is finished, the paper is folded by an automatic folding attachment, and the newspaper, still moist, drops into the holder out of the set. No matter how early you rise in the morning, you will find your newspaper ready and waiting for you. The expense of the newspaper, it may be stated, is very slight. The paper, chemicals and the electricity consumed in manufacturing the newspaper only amount to a few cents—much less than it costs to produce a standard newspaper today.

The question arises immediately, why

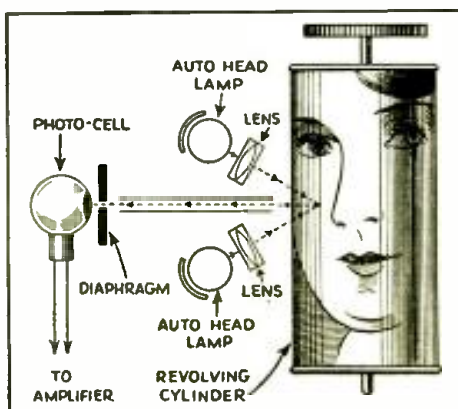

A photo is mounted on a rotating cylinder and scanned, impulses amplified and transmitted.

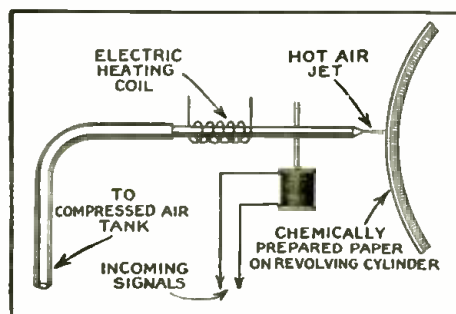

An obsolete method of recording, a solenoid controlled shutter modulates a hot air stream.

should the broadcasters set in motion all their transmitting machinery, as well as their news-gathering agency, the collecting of "spot" photographs of current events, etc.? The answer is that it will pay them to do so. They will probably accept a limited amount of advertisements and, if they obtain a sufficient amount of these, the enterprise can be made to pay for itself. Remember that,

(Continued on page 618)



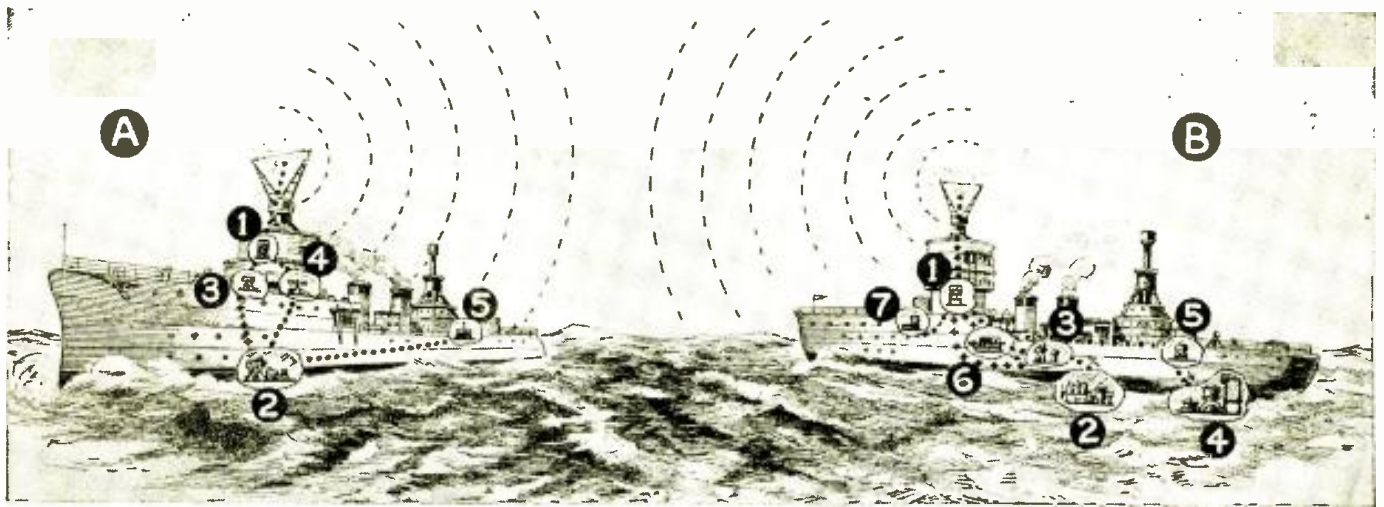

Fig. 1

In the control ship shown at A are (1) the transmitter, (2) main gyro-compass, (3) auxiliary gyro-compass, (4) gun control, (5) receiving apparatus. In the crewless ship are (1) receiver, (2) generator, (3) steering control-indicator with gyro-compass, (4) steering gear with mechanically operated rudder, (5) auxiliary gyroscope for the guns, (6) mechanism for gun control, (7) control transmitter.

# RADIO CONTROLS BATTLESHIPS

LATEST METHODS PERFECTED BY THE BRITISH NAVY FOR STEERING SHIPS, FIRING GUNS, DISCHARGING TORPEDOES, FROM A DISTANCE BY "WIRELESS."

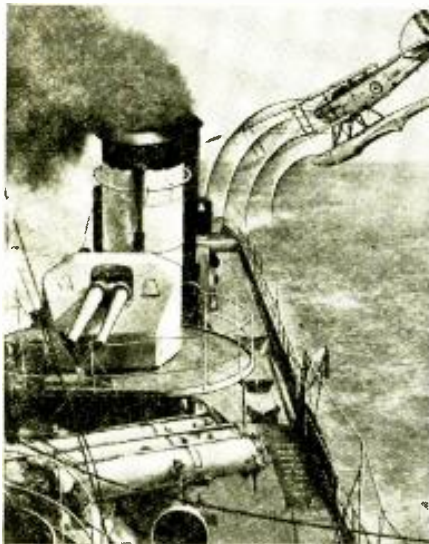

Fig. 2  
A seaplane directing the firing of guns aboard the radio-controlled ship.

**B**EFORE the ink on the peace treaty was dry the European nations began preparing for another conflict. These war preparations are no longer a secret. The question now remains, who is better prepared?

The continental nations, like France, Italy, Germany, Russia, etc., are concentrating in fortifying their land and air forces. However, the problem with Great Britain is different. British existence, since Napoleonic wars depends on her great navy. British naval supremacy must be kept up for reasons

that are well known to everyone. In order to perpetuate this supremacy she must adopt new means for protecting it.

British naval experts, since 1925, have been experimenting continuously to perfect the idea of steering air-land- and seacrafts from a distance by means of radio transmitted control waves, which was originated before the World's War. Their dream has been realized. Now, it is not only possible to steer her mighty ships without having a single man aboard, but also what is still more important

*(Continued on page 613)*

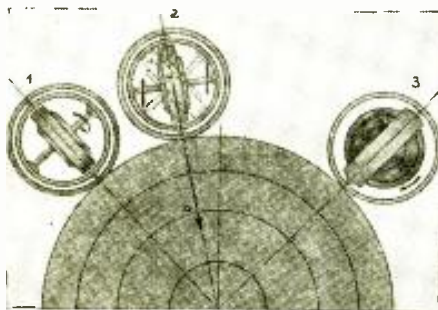

Fig. 3  
Gyroscope action in radio-controlled ship. See text for explanation.



Fig. 4  
Receiving apparatus shown on right, steering gyroscope in center.

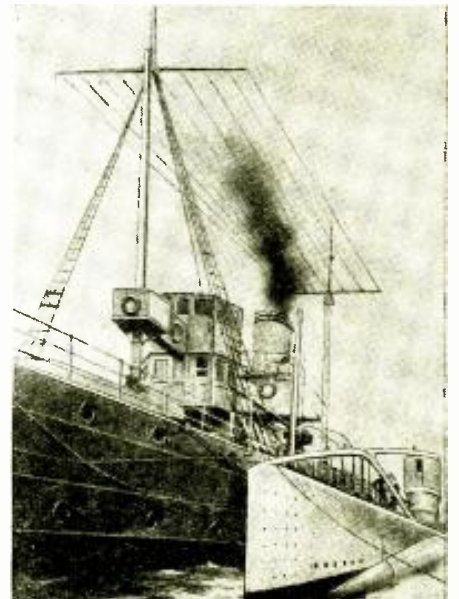

Fig. 5  
A crewless submarine lying alongside of its control ship before a trial.



# HIGH-FREQUENCY ADJUSTMENTS IN RECEIVERS

A description, in complete form, for realigning and stabilizing all types of receivers.

H. K. BRADFORD\*

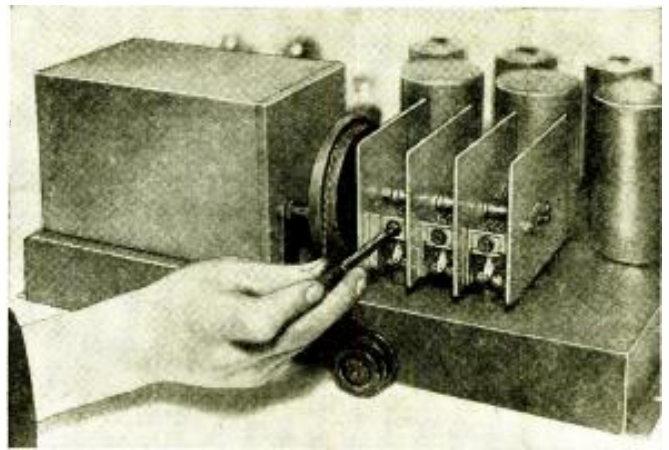

**W**HILE radio servicing definitely includes two classes of work, the Service Man really makes this distinction. These classes are: adjustment of the receiver and correction of definite trouble due to a breakdown of one or more parts in the receiver. The two problems are so intimately related in the Service Man's routine that there need be no definite division. On the other hand, one type of fault or trouble may fall in one classification whereas the Service Man may act on the other.

There is no substitute for the knowledge gained through experience with receiver troubles in distinguishing between poor adjustment and defective material. In many cases, much time is wasted attempting to "track down" some assumed defective part when the trouble may have its origin in poor adjustment. Hours spent in adjustment will prove ineffective if a defective part will not permit correct adjustment or correct operation, after the adjustment has been completed.

Without due consideration of the trouble with the necessary tests there is no absolute method of making the above mentioned distinction. A rather good rule in servicing is to make all adjustments as soon as it is possible to get a signal through the entire system. This

Chief Eng'r. Capitol Radio Research Labs.

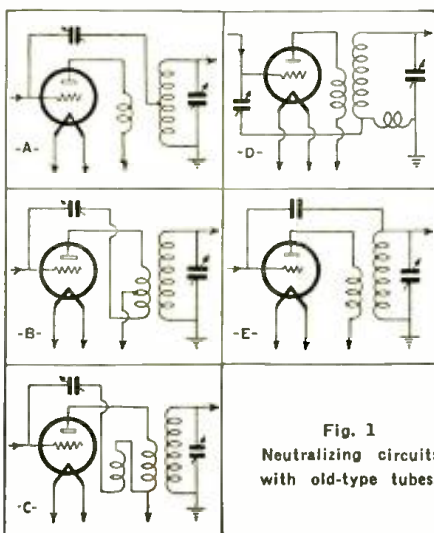

Fig. 1  
Neutralizing circuits  
with old-type tubes.

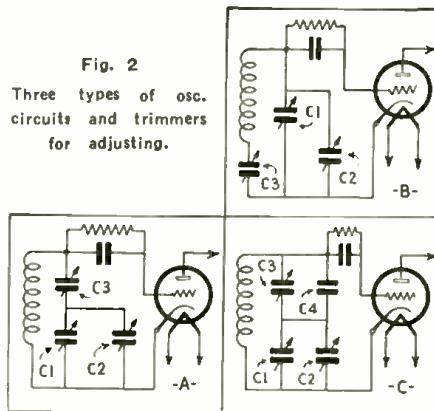

Fig. 2  
Three types of osc.  
circuits and trimmers  
for adjusting.

cannot be followed strictly as in some cases conditions will not permit such procedure. In addition, it would be unwise to make a complete alignment—neutralization and other adjustments—when a circuit correction may have the effect of undoing this work.

All possible R.F. adjustments applying to practically all receiver circuits are completely explained in the manner of a definite procedure. The order of the major adjustments and of the individual items of each major adjustment will follow.

The order in which the major adjustments should be made will depend on the type of receiver, that is, T.R.F., superheterodyne, etc., and in cases where more than one major adjustment is necessary in one receiver type, they should be done in the order specified.

For T.R.F. receivers requiring neutralization, this should be done first. The only other adjustment in the high frequency portion of this type of receiver is alignment of the tuned stages. For superheterodynes the I.F. amplifier should be first neutralized if necessary and then aligned. We next proceed with neutralization of the R.F. stages where necessary, then adjustment for synchronizing the tuned stages, finally to the tracking problem.

### Neutralization

The only other adjustment in the high or I.F. amplifiers and provided with no means of suppression of self-oscillation must be neutralized: 01A, 01B, 01C, 30, 9B, 26, 27, 37, 56, 215A, 40, WD11, WX12. These are the tubes commonly found in

the earlier-model receivers. In Fig. 1, several neutralizing circuits are shown, and of course, there are others. For a given class of receivers, that is, A.C., D.C., battery, etc., the neutralizing procedure will be essentially the same regardless of the system of neutralization used by the manufacturer.

When we have a D.C. receiver to deal with in neutralization we must realize that the filaments of such a receiver are wired in series and that the above procedure will not be suitable because we must not prevent the system from carrying signals in the process of neutralization. There are several ways to get around breaking the filament circuit—one is to break the plate circuit at the "B" supply for each individual tube as it is neutralized, making sure that the plate bypass condenser is not disturbed. Another is to apply sufficient bias on the grid of the tube being neutralized to cut off all plate current of that tube. The third, which is the most practical for the busy Service Man, is to secure a double socket adapter whereby another tube identical to the one being neutralized is used to supply filament continuity only. A fixed resistor having the same value of resistance as the tube filament will do the trick also.

For battery operated receivers and  
(Continued on page 612)

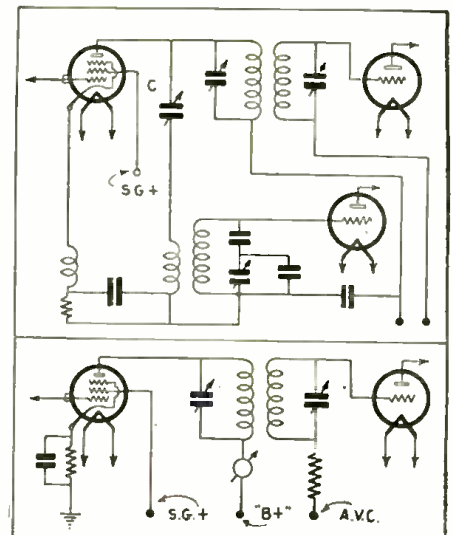

Fig. 3  
Intermediate frequency trimmer adjustments.

# TWENTY WAYS TO IMPROVE

There are, unquestionably, countless readers of this magazine who have receivers that are operating satisfactorily, and yet which do not come up to the standard that is set by present day sets. Perhaps, for the longest time they have contemplated modernizing their set, but have held off because of lack of information on this subject. If so here is all the necessary detail, which should be welcome to not only the above mentioned, but to the Service Man as well. Here are the facts—go to it boys!

**T**HERE are many thousands of radio receivers in use today that have become obsolete simply because later developments in receiver design have been made. These sets are not worthless; on the contrary they are giving their owners good service. But there is no reason why they cannot be brought up to date so that the results will rival even the most recent commercial sets. The fact that most people are more careful about spending money on such luxuries as a new radio set only makes the subject of modernizing receivers more lucrative, at this time.

To begin with, it must be understood that to cover such a general subject, it is not possible to supply actual circuits of all the available receivers. There are so many variations of the fundamental circuits in use that this would require an entire volume. Therefore, we must limit this discussion to types of circuits instead of specific examples.

In this way the man with a more or less general knowledge of set construction—the average experimenter, set builder or Service Man—can easily adapt the facts supplied to a particular receiver.

## New Tubes

One of the widest advances in the past

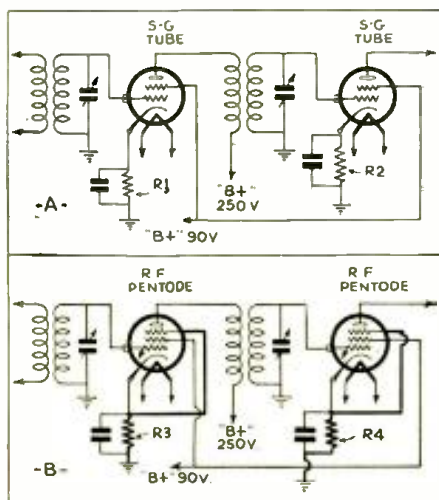

Fig. 1

A—R.F. circuit of old receiver using 24's.  
B—Circuit for employing higher-gain tubes.

year has been the development of new tubes. Those sets which use the early screen-grid tubes, such as the 24 can be greatly improved by certain simple circuit changes. The 24 type tube has a rated voltage amplification factor of 650 when a plate voltage of 250 is used. The 58, on the other hand is rated at 1,280, almost twice as much. Thus, if we can change the 24 type tubes in a set for the later 58's, we can increase the sensitivity of a set considerably.

The 58 tube is an R.F. pentode and has one more element than the 24. For this reason, the sockets must be changed from the 5 prong to the 6 prong type. This is easily accomplished, since most receivers use the wafer type sockets. The extra prong of the 6 prong socket is connected to the cathode, as shown in Fig. 1B. The cathode resistor must also be changed, to suit the new tube. Instead of the previous value (about 1,500 ohms usually), a resistor of 300 ohms is needed for each tube, where individual bias resistors are used for each stage.

Some sets use a single bias resistor for several R.F. or I.F. stages. In this case, a correspondingly lower value of resistance is required, depending on the number of tubes.

The same circuit changes can be applied to changing from the type 35, and 24A to the 58; the 32 can be changed to the 34; and the 36 to the 78.

The increase in the amplification of the newer tubes may possibly cause a little difficulty with oscillation. If this is encountered, it may be necessary to increase the size of the bias resistor or



Fig. A

A high-frequency horn for obtaining wide-range frequency response.



(Courtesy R.C.A.)

A modern radio set. Note improved design and control arrangement.

lower the voltage supplied to the screen-grid in order to lower the gain sufficiently to stop the trouble. Generally, where complete tube shielding is employed, no trouble in this direction need be anticipated. However, even with a slight reduction of the amplification per stage, there are still advantages in the use of the new tubes. The variable mu characteristic eliminates many cases of interference between stations (those which are caused by cross-modulation), and also the R.F. pentode can carry much stronger signals without overloading because the suppressor-grid removes the secondary emission so prominent in some sets using the ordinary screen-grid tubes.

The amount of reduction in gain necessary to permit stable operation is not ordinarily very great, so that the actual gain-per-stage is greater than with the previous tubes. Improvements in shielding will permit even greater amplification.

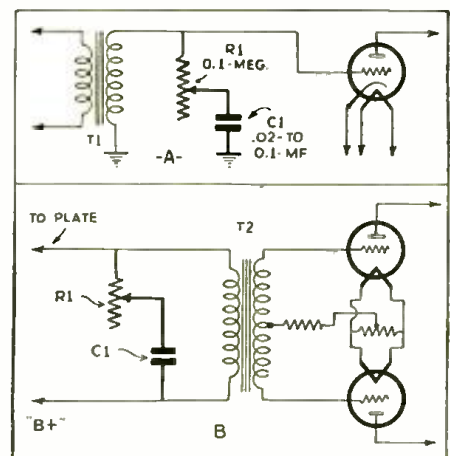

Fig. 2

A.—Regulating tone in a single power stage.  
B.—Regulating tone in push-pull power stage.



# YOUR RADIO SET — C. W. PALMER



Courtesy Crowe Name Plate & Mfr. Co.

Fig. B

Two sizes of airplane type tuning controls.

## Wide Frequency Response

The dynamic speaker under normal conditions in radio receivers is not capable of projecting sounds over the entire audible spectrum. In fact, the usual dynamic speaker does not even pass the band of frequencies transmitted by the broadcast station (about 30 to 5,000 cycles). In order to overcome this, some manufacturers have incorporated two or more speakers in their console cabinets, each speaker being especially designed to cover one part of the audible band so that the very high and very low frequencies are not lost.

The average single speaker set has a predominance of the low frequencies; sometimes cutting off as low as 3,000 cycles. In order to improve a set under these conditions, an additional speaker can be added. There are several special high-frequency speakers, such as that shown in Fig. A, available now, and it is not a difficult task to incorporate one in a console. The particular speaker shown is a dynamic which must be matched to the output impedance of the set to which it is to be added. Under some conditions, it may be connected either in series or parallel with the voice coil of the original speaker, without an additional matching transformer. However, to effect a correct match, the former method is preferable. With this speaker, too, a source of power is necessary to actuate the field coil. However, the experimenter can easily construct such a unit, or one can be purchased.

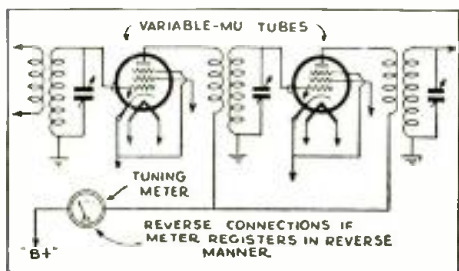

Fig. 4

Illustrating how a visual tuning meter may be wired in a receiver.

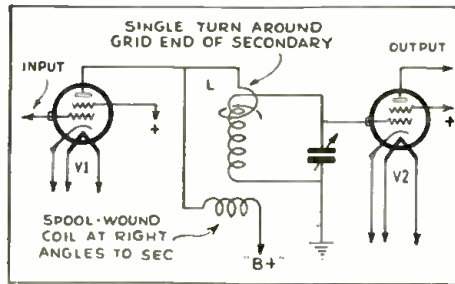

Fig. 3

Circuit employed for a high-gain R.F. coil.

The other type of high-frequency speaker available is a piezo-electric speaker, using a rochelle salt unit which drives a diaphragm similar to the dynamic unit. This type of speaker is easier to install than the dynamic type, as it does not have a field coil to actuate, and it may be connected directly across the voice coil circuit of the dynamic unit in the set. As the piezo unit has a capacitive reactance, and the voice coil circuit of the dynamic speaker is inductive, the two tend to balance, thus dividing the available power uniformly. The division of power also improves the power factor of the output circuit.

## Baffle and Cabinet Improvements

In addition to improvements that can be made by the addition of a second speaker, the actual frequency characteristic of the baffle and cabinet in which the speaker is mounted can be improved.

The first way to accomplish this is to remove the speaker from the cabinet, mount the unit on a sheet of acousti-celotex or other similar material of the dimensions of the inside of the speaker compartment and then replace the mounted reproducer in the cabinet. A hole the size of the reproducer cone is cut in the celotex. This will prevent to

(Continued on page 616)

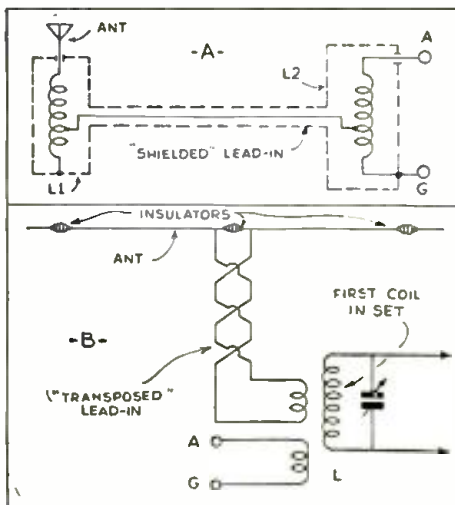

Fig. 6

A.—Method of reducing outside interference. B.—Reducing noise with a transposed lead-in.

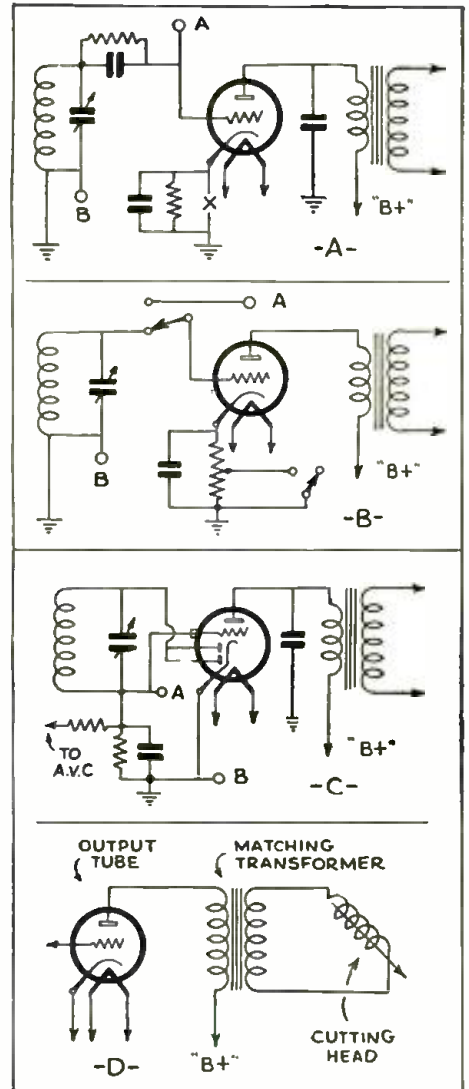

Fig. 5

A.—Phonograph connections in "grid-detector."  
B.—Phonograph in plate-detection circuit.  
C.—Connections made to grid and chassis here.  
D.—Connecting a recording cutting head to set.

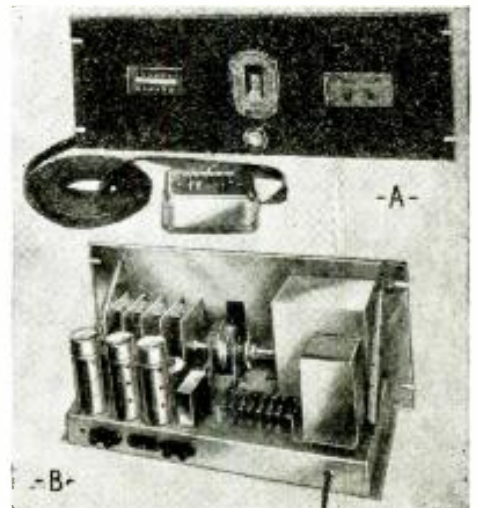

Fig. C

Service Men are augmenting their incomes by installing remote control tuning devices.

# SHORT-CUTS IN RADIO



Fig. A  
The parts of the latch-lock adapter.

## A "LATCH-LOCK" ADAPTER

Paul A. Miller

THIS is a short-cut in radio service, for those Service Men who still use Readrite analyzers. Take the plug, unsolder the 5 wire cable, unscrew the 5 prong plug from the handle, and drill a hole down through the top edgewise. Tap to hold a machine screw and cap for the grid wire of the new 8 wire cable (Fig. A).

Next cut a slot into the side of the handle about 3/16 of an inch from the bottom for the latch. Take a small 7-prong plug that screws into the handle and drill or punch a hole through the center; then take a regular tip jack and file the end of it off so that a phone tip will pass all the way through. Take a nut from an insulated-type phone tip and cut the point off as shown. Get a piece of brass and drill and bend to fit the nut; put a piece of a valve spring in between to keep the slide closed. Next take a brass rod the size of the phone tip jack and slot it as shown. Get a small 7-prong socket and make your own adapters as illustrated.

## A CHASSIS BENDER

From "Amateur Wireless"

A VERY simple device made of odd pieces of wood which is very satisfactory for obtaining neat angles. The drawing, Fig. 1, is very simple and is self explanatory.

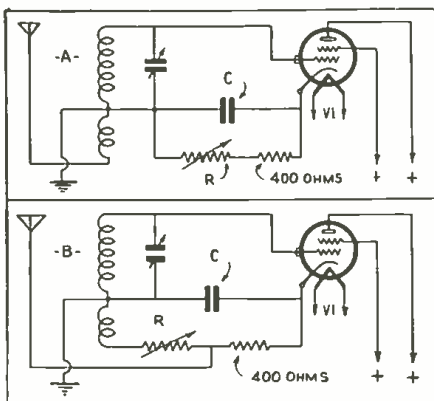
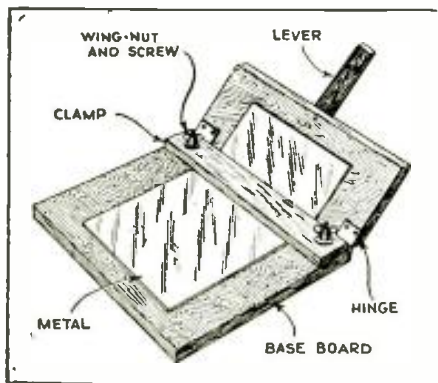

Fig. 2  
A volume control method that is effective.

## VOLUME CONTROL REPAIR

H. D. Hatch

I REPAIRED a set in which the volume control was a variable resistor in the cathode circuit, as shown in Fig. 2A. The value of the resistor was 10,000 ohms and the only substitute available was a 4,000 ohm unit and when installed did not cut the volume enough on loud locals. After some thought, I changed the wiring to that of Fig. 2B. Now R and the 400 ohm resistor make a potentiometer which is more effective.

## A SENSITIVITY CONTROL

E. W. Little

AT the present time manufacturers of radio sets produce receivers that have even sensitivity at all points of the band. Some times a customer desires more sensitivity on the lower wavelengths. This is solved by the connection of a small condenser as shown in Fig. 3, and then re-alignment of the first tuning condenser.

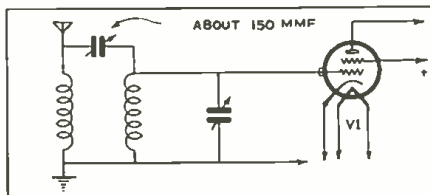

Fig. 1, left  
A simple chassis bender made at home.

Fig. 3, above  
A device for increasing H.F. sensitivity.

Fig. 5, right  
A gas engine power unit for "the sticks." Use a standard "voltage divider" resistor.

Hints, "kinks," ideas and suggestions that enable the amateur and professional to save time and money.

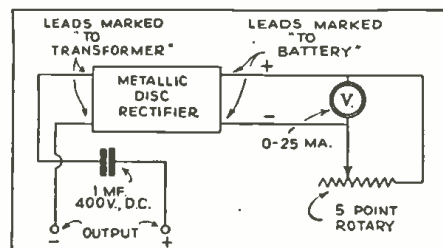

Fig. 4  
An output meter made from simple parts.

## A SIMPLE OUTPUT METER

Frank Hehre

QUITE a few Service Men have been looking for a suitable output meter for use with practically all sets. This is the one I use. The metallic disc rectifiers used some years ago for charging storage batteries along with a 0-25 ma. meter make up this unit. A Kuprox 110A unit is used.

The shunts are made to give four ranges; by doubling, tripling and quadrupling the original scale. See Fig. 4.

## A BACK-WOODS POWER UNIT

Marine Schell

WE needed a radio at our scout cabin in the woods; city power was not available and because we use it but once a week I thought that batteries would be too expensive.

So I decided to build a gas engine power plant. Luckily I had a 220 V. D.C. motor which gives about 300 V. D.C. turning at 2,200 r.p.m. I belted the engine to the generator with a V belt and a 4 in. pulley on the engine, and a 2 in. pulley on the generator. I used an old Maytag washing machine engine. The filter consists of a 30 hy. choke and three 2 mf. condensers. See Fig. 5.

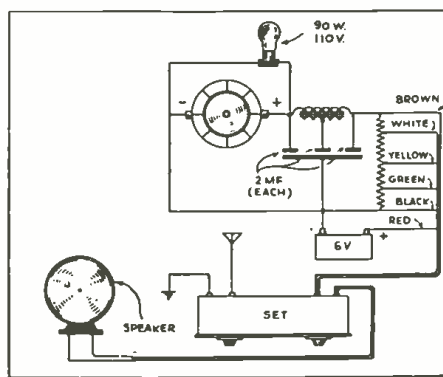



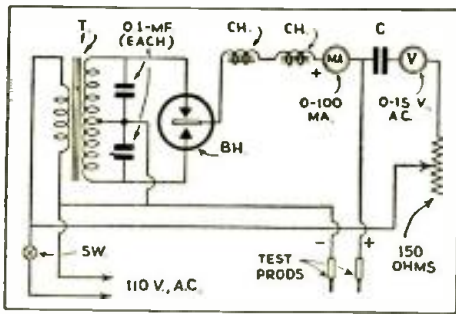

Fig. 6  
A test unit for electrolytic condensers.

## ELECTROLYTIC CONDENSER TESTER

E. A. Redmon

THIS tester will measure the capacity of a condenser and at the same time measure its leakage. To measure the capacity we must use alternating current and as we cannot use A.C. alone on an electrolytic condenser a rectifier is employed (a "B" eliminator will do as a substitute) as shown in Fig. 6. The voltmeter measures the capacity by calibrating the scale against known condensers and the leakage should not be more than 1. ma. per mf.

## A UNIQUE VOLUME CONTROL

Milton S. Solberg

IN experimenting with a variety of hook-ups using R.F. amplification, I use a type of volume control shown in Fig. 7. It consists simply of a modified form of tone control, the difference being that a larger condenser is used. A 50,000 ohm resistor in series with a 1 mf. condenser gives good results connected as shown.

## A TEST PROD IMPROVEMENT

M. C. Clapp

IF you use phone tip prods but occasionally have use for a sharp point, a bayonet can be made as shown in Fig. 8.

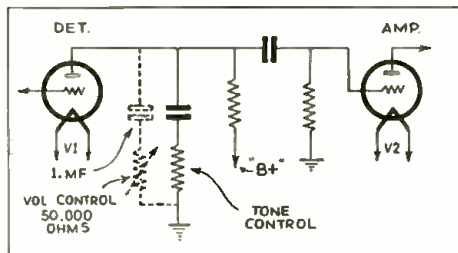

Fig. 7  
An unique experimenter's volume control idea.

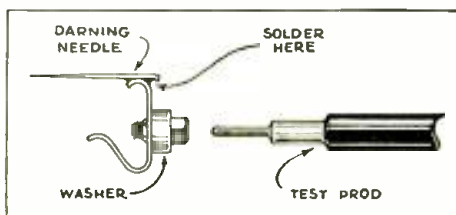

Fig. 8  
Test prods from phone tips and jacks.

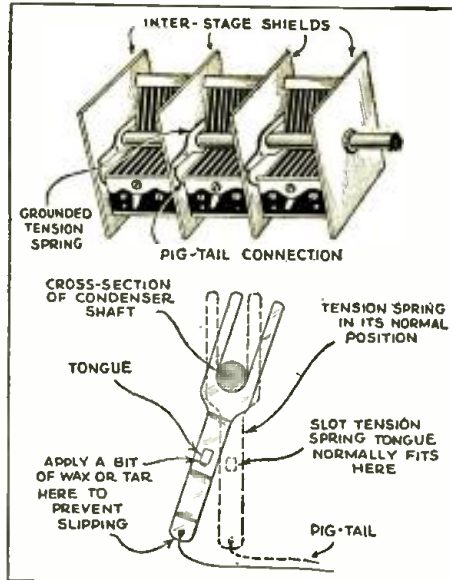

Fig. 9  
A way to fix noisy tuning condensers.

## NOISE IN TUNING CONDENSERS

Boris S. Naimark

MANY modern receivers employ grounding tension plates between the rotors of the condenser sections and the inter-section shield plates. When these lose their tension the receiver becomes noisy. In some cases, they can be cleaned, but it is usually better to replace them with short pigtail connections. See Fig. 9.

## A TUBE-NOISE INDICATOR

H. W. Malmstrom

IT is easy to sell a customer a new tube to replace a noisy one that tests good otherwise, if you can duplicate the noise that the customer hears in his set. Here is a simple but effective noise indicator that can be easily added to any tube tester that measures the plate current in the tube. It will give an audible demonstration of noisy tubes due to defects of a mechanical nature. A tube that has loose elements, erratic opens or shorts will cause variation in plate current when it is tapped. If a speaker is connected in series with the plate lead of the noisy tube being tested (in

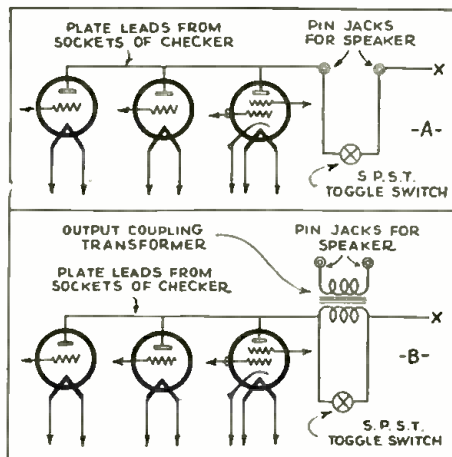

Fig. 10, above  
A noise indicator for the tube tester.

Fig. 12, right  
Methods for renovating a tube tester. It may be unnecessary to discard "old reliable."

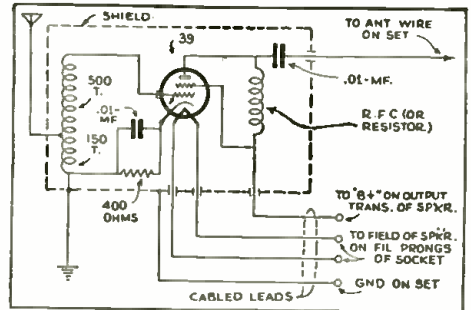

Fig. 11  
An untuned R.F. stage for the auto set.

the analyzer) it will produce static that will convince the most skeptical customer that the tube is defective. (Fig. 10.)

## A SENSITIZER FOR THE AUTO SET

Malcolm Mackay

IN WORKING with automobile receivers, especially those designed a year or two ago, I have found that many of them did not have sufficient sensitivity for use in this part of the country. Unless the car is traveling within a comparatively few miles of a station, it cannot be heard.

With this in mind, we built an untuned R.F. stage consisting of a 39 tube enclosed in a metal box just large enough for the tube and a few R.F. chokes, etc. Referring to the circuit diagram, a coil is made by winding 650 turns of No. 33 wire on a small machine screw. Choke R.F.C. is a standard type of R.F. choke designed for S.G. tubes.

The remainder of the parts used in the unit are evident from the circuit. The bias resistor has a value of 400 ohms, bypassed by a .01-mf. condenser. Another .01-mf. condenser is used to couple the untuned amplifier to the receiver.

## AN OLD TUBE TESTER—UP TO DATE

Iver Paulsen

THE Sterling R-409 AC, is an old timer made to test and reactivate 01A and 199's, which makes it practically useless to-day, but with a few minor

(Continued on page 618)

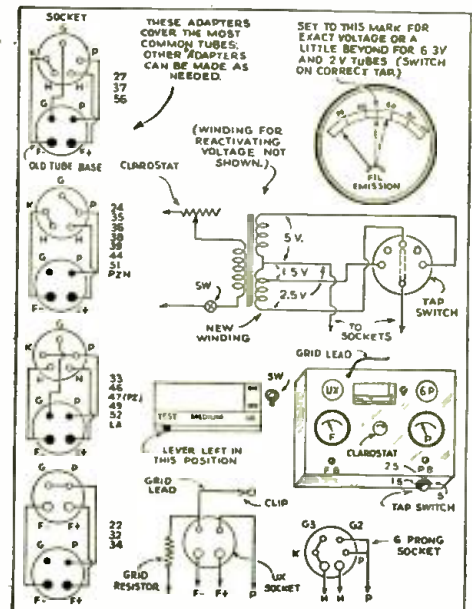

# FACTS ABOUT DYNATRON OPERATION

## PART II

C. M. DELANO

The first chapter dealt with theory in a non-technical style; in this closing chapter circuits are described.

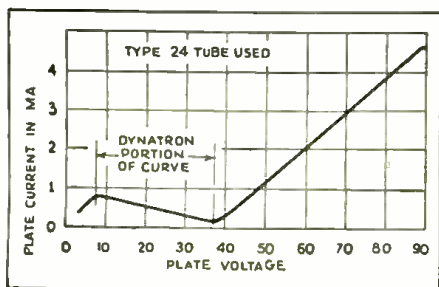

Fig. 6  
Dynatron portion of curve for 24 tube.

NASMUCH as the next tube to be considered is of the screen-grid type, it follows that one more element is available than was the case with the 3 element tube previously considered. It is practical to take advantage of this fact and put the extra element to good use in our circuit. Using the hook-up shown in Fig. 5, we can plot a graph along the lines indicated in connection with the discussion of the 3 element tube. Such a graph as the one already considered is representative of the usual type, with one exception; not all tubes will exhibit dynatron characteristics which indicate a reversal of direction when the graph crosses the base line. Many tubes indicating the dynatron characteristics operate in such manner that the downward slope of the characteristic dynatron curve ceases and the curve shoots upward before the base line of the graph is reached. (Notwithstanding what has been said in regard to screen-grid tubes being better for dynatron circuit purposes than the usual 3 element tubes, it is interesting to note that the curve already shown applied to a type 26, 3 element tube.) Figure 6 shows a graph plotted for a type 24 tube; in general it is found with plate voltages between 0 and 90, that the dynatron portion of the characteristic curve is found between plate voltage limits of about 8 and 38. Curves may also be plotted with plate voltages supplied by a single 45 V. battery but the general shape of the curve will change but slightly; different values of screen-grid current, too, will slightly alter the curve.

### Uses of the Dynatron

The question as to what practical use may be made of the dynatron, or, as it is properly termed, the "pliodynatron"

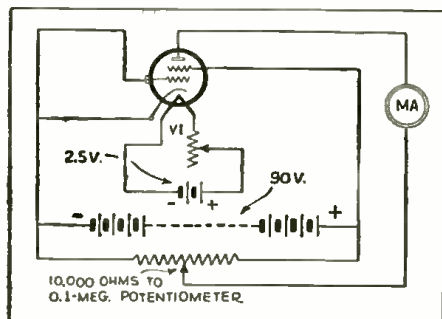

Fig. 5  
For checking dynatron characteristics.

when a 4 element tube is used, will now be considered.

The dynatron circuit is exceedingly useful as an oscillator generating R.F. currents, and in this connection the Service Man and experimenter will find it both practical and simple to construct and also very stable when frequency variation is considered. Some writers who have expressed themselves on this subject have gone so far as to say that the dynatron oscillator compares favorably with temperature-controlled crystal oscillators, although the writer has no data to support this contention. A hook-up which the writer has found very satisfactory for signal generation in connection with aligning both T.R.F. and superheterodyne receivers is shown in

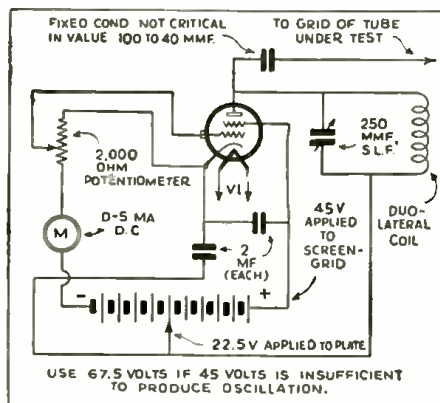

Fig. 7  
Dynatron oscillator circuit for 24 tube.

Fig. 7. The writer claims no credit for this circuit as it is a combination of circuits originally published in another magazine. Other methods of coupling the oscillator to the receiver may be employed, however, the writer does not recommend them to the beginner in this kind of experimentation and they will not be discussed at this time. Someone has referred to the dynatron as being a feeble oscillator. Under certain conditions this is true, but in general the writer has found that under identical oscillator tuned circuit voltage conditions there is no difference in signal strength between the dynatron oscillator and the more common types. Certain people, at times, in experimenting with the dynatron oscillator circuit, have come to the conclusion that a given dynatron hookup would oscillate better at some point in the spectrum than at others within the limits of the tuning

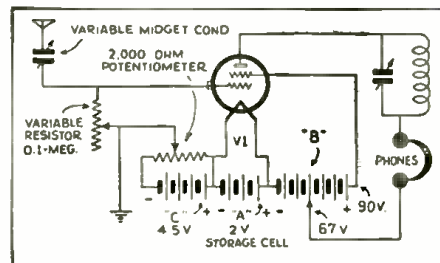

Fig. 8  
Dynatron biased detector—32 tube.

system employed, and only through a narrow band at that. The writer has found that the old-time "honeycomb" or duolateral type of coil tuned with a straight line frequency condenser, when used in the dynatron hookup, makes a very satisfactory and easily changed tuning inductance (in this connection it is proper to note that the October, 1933 edition of RADIO-CRAFT, page 230, contained some very complete and timely data on the choice of proper coils and condenser values as this pertains to the use of duolateral inductances). In addition to the fact that the dynatron circuit lends itself readily to the use of simple types of tuning inductances which may be easily interchanged, it is also true that the dynatron oscillator can emit many harmonics and it is possible to do a lot of practical and useful work with this circuit by making use of different harmonics. The problem of identifying harmonics is one that is very interesting but inasmuch as it has been discussed in detail in past issues of RADIO-CRAFT and in several other publications it will not be dwelt upon in this article. (Anyone desiring information on this should refer to the July and August, 1932 issues of RADIO-CRAFT for detailed information). The R.F. oscillator is invaluable in service work. If

(Continued on page 625)

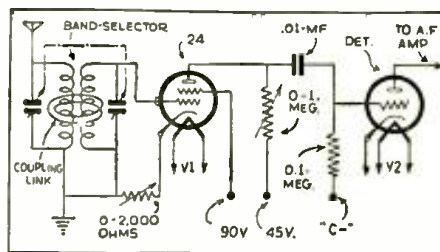

Fig. 9  
Dynatron radio frequency circuit.



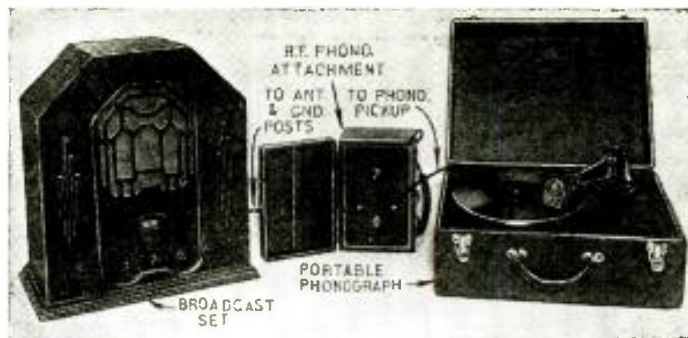
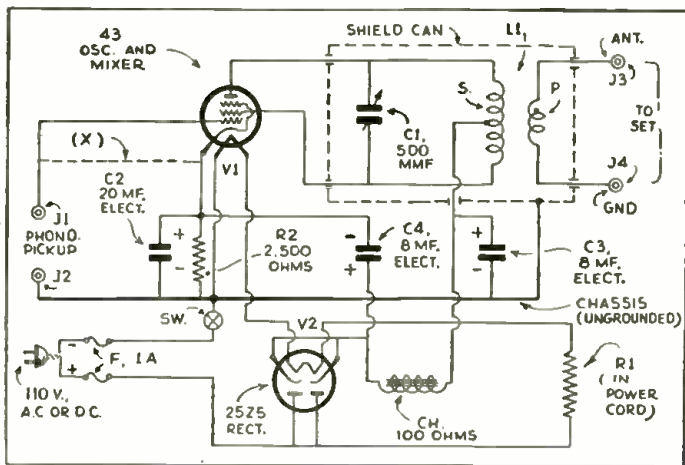

Fig. A, above  
The pickup "feeds" the "Ant." and "Gnd." posts of the radio set.

Fig. 1, left  
Completely lettered diagram of the R.F. phonograph attachment.

## HOW TO MAKE A NOVEL, PORTABLE, A.C.-D.C.

# R. F. PHONOGRAPH ATTACHMENT

R. D. WASHBURNE  
and N. H. LESSEM

WHILE radio is a very wonderful invention, it would be even more wonderful if, by merely throwing a switch, we could select the very music or programs which we desire to hear at any particular time. This is exactly what this "R.F. phonograph attachment" will do when connected to the antenna and ground posts of any radio set. Have you ever had the experience (or shall we call it embarrassment) of not being able to furnish, let us say, dance music at a social gathering, simply because there was none to be had over the air?

With this little device you can, in a moment, take any phonograph record and reproduce it electrically through your regular radio receiver—without touching the interior of the set, or using any type of "adapters." In this manner you can choose your own programs for particular occasions and not be dependent entirely upon radio stations!

In the first place, a phonograph pickup cannot be conveniently or efficiently added to a surprisingly large number of radio sets. In many instances, the removal of an "overall" shield will destabilize the receiver; in others, the removal of an individual tube shield produces the same result. Some sets do not have sufficient clearance to permit an adapter to be used; others go into circuit oscillation if a lead is brought out of the detector tube socket; anyway, still other adapters would be needed to adapt the attachment to the various

types of detector tube sockets and circuits in the sets encountered. Also, when a pickup is connected into a tube circuit it is seldom that exactly the correct matching of values can be obtained; this results in a loss of fidelity. Finally, even if the set is equipped with phono-pickup connections, only the amplification of the A.F. section of the radio set is available, whereas, the use of the "R.F. phonograph attachment" permits the amplification of the R.F. section also to be utilized.

This device, a "radio frequency phonograph attachment," is illustrated in Figs. A and B; as the schematic circuit, Fig. 1, indicates, the connections are extremely simple.

First of all, note the simplicity of the design; there are only two tubes, two resistors (one of which is built into the power cord), one coil, one small-space variable condenser, one small filter choke and three fixed condensers, as major components.

### How to Use It

To use the portable R.F. phonograph attachment, first remove the antenna wire from its binding post on the broadcast set, and permit the wire to lie unused. Next, connect a wire from "ANT" of the attachment to the antenna post of the broadcast set; and another wire from the "GND" post of the attachment to the ground post of the set (the latter, in addition to the regular ground wire,

(Continued on page 620)

### FEATURES

- (1) Operates on either A.C. or D.C.
- (2) Attaches to any radio receiver, without recourse to adapters.
- (3) Wires to "Ant." and "Gnd." posts.
- (4) Uses any high-impedance pickup.
- (5) Utilizes R.F. amplifier of set.
- (6) Requires only 2 vacuum tubes.
- (7) Compact and inexpensive.
- (8) Resistor in power cord prevents high heat dissipation inside unit.
- (9) Easy to build and operate.
- (10) Portable—weighs only 4 pounds.
- (11) Versatile—may also be used with a double-button microphone, and matching transformer, as a public address unit for addressing small gatherings, via any conveniently available radio set.

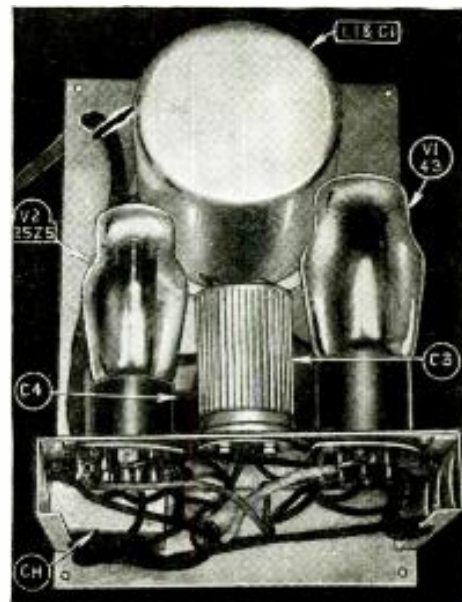

Fig. B  
Rear view of the phonograph attachment.

# A NEW METHOD FOR AUTO NOISE ELIMINATION

Aircraft radio installers get good results by the simple method of complete shielding. In this article, the author tells how the auto-radio man may duplicate that method.

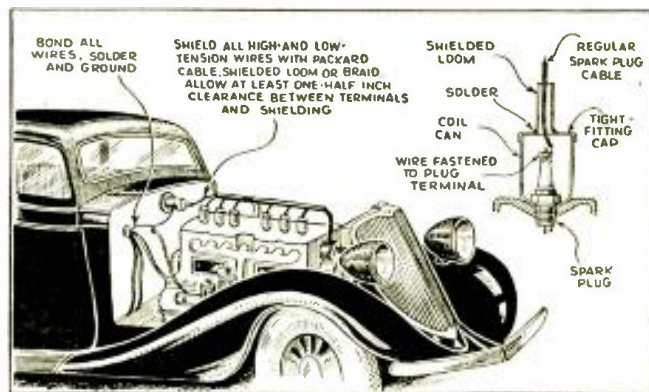

Fig. B  
Illustrating how to shield spark plugs with coil cans.

J. T. BERNSELY

TO those in the auto-radio installation and service profession who have encountered all sorts of trouble in eliminating ignition noises after a radio has been installed in a car, or who have had complaints from the car owner that the installation of the set seemed to affect the efficiency of the car, the contents of this article may prove a godsend. It is an established fact that the elimination of noise is easier in some cars than in others. In the case of the Buick automobile, for example, the procedure is very simple and excellent results are obtained; primarily due to the fact that the motor is of the "valve-in-head" type and hence all spark plugs are completely shielded. Also, due to this feature, no suppressors are necessary except one to the high-tension lead (center contact) of the distributor. As a result of the elimination of suppressors in this type of car installation, practically no decrease in the motor efficiency is experienced after the installation is made.

To some, the statement that suppressors materially affect the motor per-

formance may be news, yet it is an absolute fact that the decrease in efficiency, in some cases, is as high as 20 per cent. The author has gone into detail, on this subject, with a number of master mechanics, besides having made personal tests, and has had this fact verified. The insertion of a resistance, generally about 25,000 ohms at the spark plug end of the high tension lead and again in the high tension lead at the distributor, produces a total resistance in this circuit of 50,000 ohms. Although the current here is small and the resultant voltage drop of a low order, the effect of heat on the value of these resistors is tremendous, particularly on certain types of suppressors.

In most cases, the resistance value of the suppressor decreases, especially when it is of the carbon type, which serves to reduce the efficiency of the unit as a noise eliminating device. Then again, the resistor after a few months of use will become damaged or defective, due to the constant dissipation of energy that takes place when current flows through it, which generally results in a "missing plug" and consequent loss of power. However, the following explanation is probably the real reason for the decrease in motor efficiency after the suppressors are connected to the spark plugs.

The amount of energy that is supplied to the primary (during the interruption of the breaker points) and transferred to the secondary winding remains constant for that short period. Now if we assume that the complete circuit of battery, breaker points, primary and secondary windings of the spark coil, and up to the contact points of the plug as equivalent to a resistance "R," and the spark gap resistance as "Rx," then the energy dissipated in "R" we know to be useless, whereas the energy dissipated in "Rx" is useful, since it is expended in creating the spark discharge for igniting the gas mixture. (See Fig. 1.) It is therefore logical that any added resistance (in the form of suppressors) introduced in that circuit existing outside of the plug points would only dissipate additional energy uselessly. The net result, when this addition is made, is that an inferior spark is obtained and conse-

quently the performance of the car is affected. Unfortunately, no actual data is available concerning the resistance at the plug gap, during the discharge, which incidentally is a variable factor, and which would permit us to calculate the actual effect of the added suppressor in the form of additional dissipated energy.

The fact that this method of eliminating noise from radio reception in a car never was completely satisfactory is in itself sufficient reason to condemn it. Installation men who are constantly installing radio sets in cars, are well aware of the fact that generally there is considerable additional work to do to eliminate the ignition noise, even after the suppressors are installed. In most cases the noise, at that point, is generally found to be due to the antenna pick-up of the spark discharges as they occur at the various plugs. This in itself is proof of the inadequacy of the suppressor, since, if this device was efficient in accomplishing its purpose, no radiations would occur.

What then should be done to successfully eliminate ignition noises when a radio is to be installed in a car—and yet maintain the motor efficiency that was existent prior to the installation? In seeking a better method we would do well to first ascertain the methods employed by aircraft radio engineers when installing receiving equipment in planes. Naturally, we would find in this instance the efficiency of the plane and motor considered uppermost since the safety of the plane, passengers, and pilot depend upon this factor. Devices that would in any way tend to diminish this

(Continued on page 628)

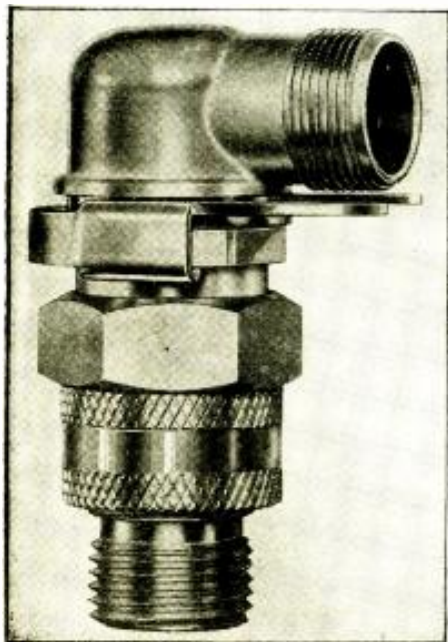

Fig. A  
A shielded spark plug for airplane motors. Name of manufacturer supplied upon request.

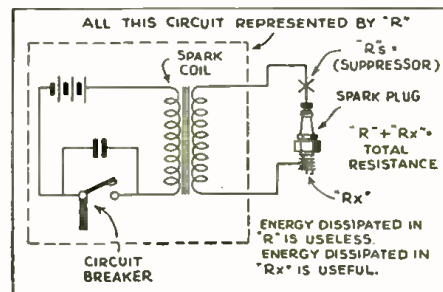

Fig. 1  
A better spark is obtained without suppressor.



# SERVICING THE "TALKIES"

In this article the author deals with the manager's problems and the best method for approaching him. Some very valuable suggestions are made in this connection.

PART VI.

AARON NADELL



A typical small-theater amplifier, incorporating volume control, fader switch, and monitor jack.

In most theatres, the man who has power to place orders—and sign checks in payment—is the manager.

Consequently, before we are ready to consider definite and concrete ways in which theatre and Service Man can be of use to each other we must first determine the considerations that are most likely to persuade him to say "yes" instead of "no."

## Show Business and Managers

The manager is a showman (that is his profession) selling his public psychological intangibles. Therefore, it is very necessary to catch his attention and capture his imagination. Talk about occluded gas in vacuum tubes, or molybdenum plates in vacuum tubes means very little to the manager himself; and if molybdenum is something Mae West hasn't got, his customers won't be interested. Therefore, you must first talk about what you can do for his show—and his budget.

Although there are many concrete ways in which the radio man can be of use to the theatre with good profit to himself, not a few will revolve, directly or indirectly, around the manager's problems of advertising and ballyhoo; those that center directly upon exploitation will be of the greatest initial use to the radio man in selling his services to the manager.

## Advertising—Ballyhoo—Tie-Up

Like the radio store, the theatre sells a luxury. Unlike the radio store, it has to sell the same luxury over again to the same people, two or three times a week. Most folks that do not have a radio—want one; most folks that have poor "radios" want a better one. But no one wants to go to the movies every night. The manager's problem is to make as many persons as possible desire to go to the movies as many nights per week as possible. To do that he advertises, but—what has he got to advertise? All he sells is time—two hours, more or less, in a more or less comfortable seat. He advertises glamour, romance, adventure, commodities he cannot weigh out for his patrons, or tie up for them to carry away. At least, he tries to advertise those things, but in themselves they are too difficult, too intangible, to solve his problem wholly. Therefore, he relies on other methods when he can get them. He has two chief resources, ballyhoo and the tie-up.

Essentially, ballyhoo is anything that will attract attention. It is likely to be mighty expensive and therefore occupies a large percentage of the manager's thoughts. This will partly explain why any radio man is likely to encounter a degree of disinterest if he walks in cold to offer to save the manager some part of his battery costs. The manager will probably be too busy wondering whether he can afford to send a truck-load of singing harpooners through the streets to advertise "Moby Dick," or obtain prizes that may prove awards of interest to every member of the family, or a thousand-and-one other ideas. He is a business man, not a technician, and although a breakdown in the show is very important to him—and he will do almost anything to avoid it, even listen to a lot of engineering talk, if necessary—his most important thoughts are naturally and quite properly

centered elsewhere, and must be recalled before he is in a mood to listen to a talk on electricity.

The tie-up is a means used by theatres to keep their advertising and ballyhoo costs within reasonable limits. The essence of the tie-up (here again the Service Man enters the picture) is to obtain advertising or ballyhoo by a swap of some kind rather than a cash payment.

Those prizes, for example. They may be bought by the theatre; but they are quite as likely to be donated by a local store, which in return will receive all the advertising the theatre can give, from the stage, in the lobby, perhaps in part of the newspaper space paid for by the theatre.

But this is only one of almost innumerable forms of tie-up. For example, that truck-load of harpooners to publicize "Moby Dick." A P.A. amplifier on the truck would be very helpful; the theatre may be willing to rent one from the Service Man, and pay for the rental in cash; but he is more likely to try to offer payment in the form of an exhibition of radio receivers in its lobby, together with the card of the radio merchant or Service Man.

The average theatre manager will spend a good deal of time working out new methods of tie-up; he is always willing to listen to any new suggestion along those lines.

But ballyhoo, advertising, and tie-ups are very far from being the only concerns of the manager. In order to understand just what part sound equipment and servicing play in the thoughts of this autocrat of the theatre it will be well to glance briefly at a list of some of the typical exhibitor's other responsibilities.

## Responsibilities of the Manager

There is *booking of the show*; selecting the pictures to be shown and the most suitable dates on which to run them. Then there is *arranging the show*; the order in which feature, news reel and shorts are to appear; it is sometimes thought poor showmanship to run a slap-stick comedy directly after a serious drama—a newsreel, at least, should intervene. Also, the *timing of the show* is important: the second show of the evening should begin in time to catch the greatest crowd, and much the same idea applies to holiday showings.

Then the manager is in charge of "maintenance," under which heading sound equipment is included. He has the roof fixed, and the plumbing seen to; he buys carpets, chairs, painting, electric light bulbs in all colors; he must keep the theatre well cleaned at the smallest cost; he is responsible for any safety hazard (such as loose carpet on a stair case, or even chewing gum on a seat) that may injure patrons or their clothes. He buys all projection room parts, supplies and repairs, and all equipment needed back-stage, if there is a stage. As an employer of labor he hires and supervises projection operators and stage-hands, porters and cashiers, ushers and advertising writers, not to mention the harpooners-for-a-day who ride about town on the ballyhoo truck. (But in a very small theatre the manager may run the projection himself, his wife sell tickets, both of them sweep up

(Continued on page 612)

# SAVE YOUR OLD TUBE TESTER

For those who desire to rewire and convert their old but expensive tube testers, here's a complete article with all data, that will permit them to make this change with little expense or trouble. To get an idea of how simple, efficient, and up to date this unit is, just glance at the following features.

1. Brings obsolete testers up to date.
2. Economical, may be built for less than \$6.00.
3. Supplies all new filament voltages, all instructions engraved on panel.
4. All new tubes listed on panel.
5. Simple to operate.
6. Provides for future changes.

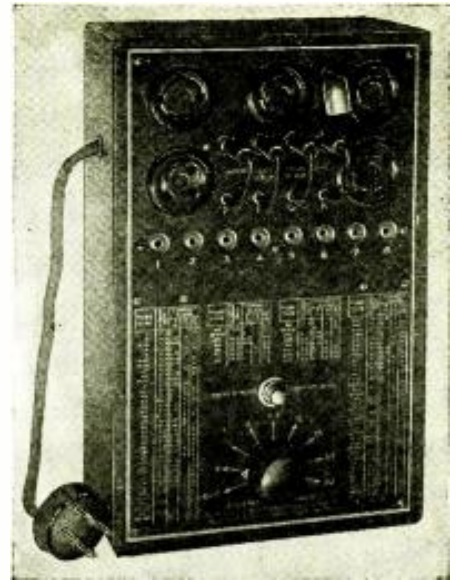

Fig. A  
Front view. Instructions engraved on panel.

MILTON REINER\*

ONLY a small percentage of the total number of tube testers, which are owned by Service Men, dealers and distributors are up-to-date. In most instances the owner of a tube checker cannot test many of the new tubes that are in frequent use in receivers today and this predicament presents an embarrassing problem which often results in the loss of confidence by the customer.

The serious deficiencies of the obsolete testers may be classified as follows: (1) Lack of new sockets to accommodate the new tube bases; (2) Lack of proper filament supply to operate the tubes; (3) Lack of circuits to apply re-

quired test voltages to various elements and to provide inter-connection of different tube elements.

Although an up-to-date and economical tube tester was described by the writer in the August, 1933, issue of RADIO-CRAFT, and many testimonial letters acclaim its value, there are many owners of testers who do not feel justified in scrapping an expensive, well-made instrument, which they have, because it is obsolete; and getting a new one that is not as pretentious, nor as costly. For this group of radio mechanics and dealers, the author has designed a comprehensive adapter that will bring their

obsolete testers entirely up to date, at a very nominal cost.

This device is designed to overcome the deficiencies mentioned above. The instrument is designed to test tubes as triodes, which is the fundamental circuit of almost all the "obsolete" equipment on the market; also, this "super-multidapter" is extremely simple to use. (The 4 prong plug of the super-multidapter cable is inserted in the 01A socket of the old tester and from then on it is an easy matter to test a 25Z5, 6F7, 12Z5, 48, or any other type tube).

Figure A illustrates the complete unit. (Continued on page 634)

\* Chief Engineer, Radio City Products Co.

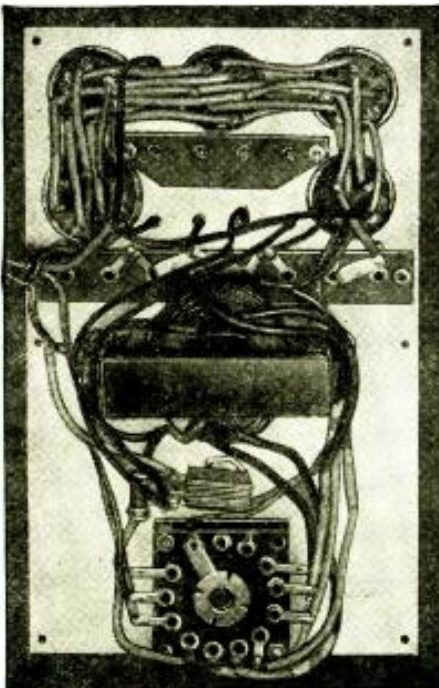

Fig. B  
Back view, showing location of parts.

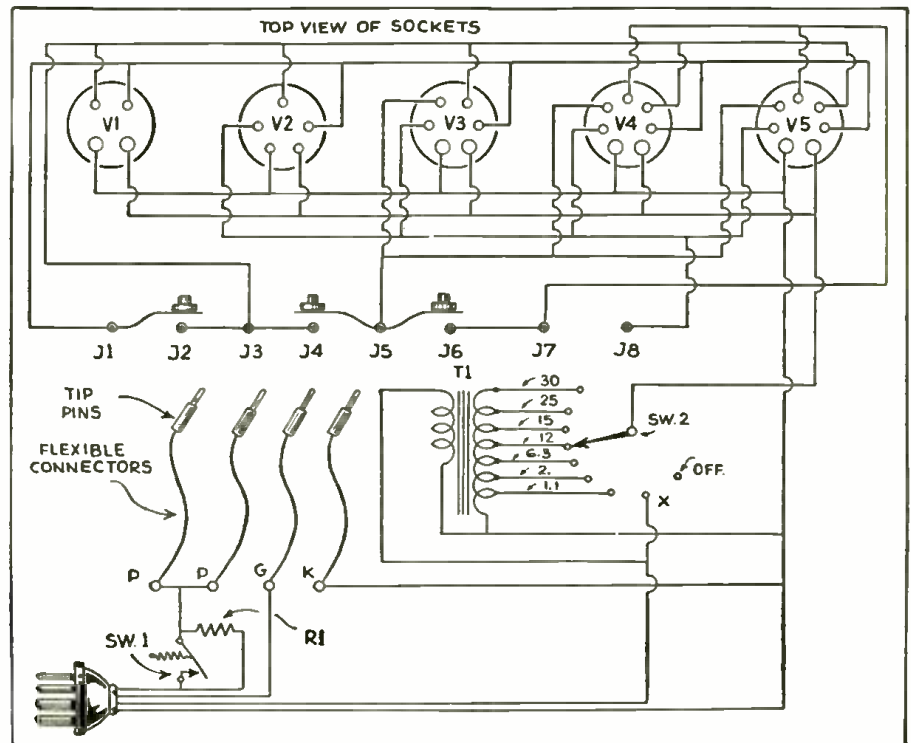

Fig. 1  
Wiring diagram of a "super-multidapter," the transformer supplies all requisite voltages.



# BEGINNER'S 3 TUBE ALL-WAVE SET

F. R. HARRIS

Here is a more advanced, yet simple and easily constructed, set for the newcomer to the radio field. It will receive both short-wave and broadcast-band stations, and although headphones are recommended loudspeaker results can be obtained.

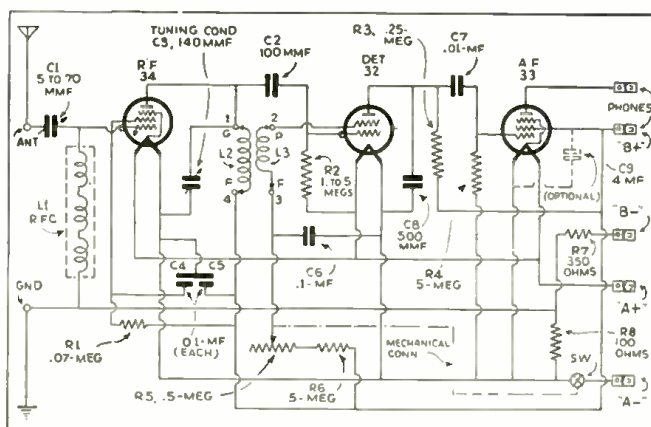

Fig. 1  
Schematic diagram of the 3 tube beginner's set.

IN THE February Beginner's Department we described a simple, 1 tube, all-wave set designed to serve as an introduction to the short-wave field. At that time the prediction was made that, having once gotten into short-wave work, you would not be satisfied until you built a more elaborate outfit. There has been plenty of time since then for you to get thoroughly acquainted with the possibilities—and limitations—of your 1 tube job; hence, we present this time a 3 tube set that should reach out and bring in those elusive stations that you just almost got on the smaller set, and will bring in the stronger ones on the loudspeaker.

## The Circuit

Ordinarily, a 3 tube circuit would involve considerable complication but in this particular layout the main consideration has been simplicity, which of course involves some sacrifice of other factors, but, on the whole you will find that the performance of the finished product will amply repay the time and effort spent upon it. It makes use of an untuned antenna input to the control-grid of a type 34 tube. The plate coil of this tube constitutes the only tuned circuit in the set, and the only coil that must be changed in going from one band to another. (See schematic diagram Fig. 1.) The signal is fed to the type 32 tube, operating as a grid detector, through the condenser, C2, serving the dual purpose of acting as grid condenser

and isolating the plate voltage from the grid of the detector tube. The leak, R2, serves to keep the grid from "floating" and to give it the slight positive bias, (due to its being returned to the positive leg of the filament), which makes for greatest sensitivity for this type of detection. The signal, which is now of audio frequency, is then fed to the grid of the type 33 tube through coupling condenser, C7, and thence to the phones or speaker. Regeneration, necessary for sensitivity, selectivity and to permit code reception, is obtained by feeding the screen-grid of the detector tube through the tickler on the tuned coil form and is controlled by varying the voltage on the screen-grid by means of the potentiometer, R5.

The set has been laid out to be constructed on the same panel and baseboard as the previous one—although this time the batteries will have to be put elsewhere as the set occupies the entire baseboard. The first thing to do, therefore, if you have built the previous set, is to clean everything off the baseboard, unsoldering all wires and cleaning out all connection lugs.

For those of you who are starting "from scratch" of course the first thing to do is to cut the panel and base to size, drill the panel with mounting holes along the bottom and for the tuning condenser and potentiometer, then mount it on the baseboard, after which the condenser and potentiometer can be put in place.

Next, screw all parts down to the baseboard. The locations are very clearly shown in the back view (see Fig. B). On the extreme right is the input choke, next to this the type 34 R.F. tube, on the left the type 33 output tube. Next to the panel the socket to the right is for the coils and to the left for the type 32 detector tube. Mount the seven fahnstock clips as shown—two on the right for antenna and ground, three across the back for "B" battery and phones, and two near the panel on the left for the "A" battery.

Wire up the filament circuit, being sure to include the switch which is an integral part of the potentiometer specified in the circuit—and don't forget a

wire connecting the rotor lug of the tuning condenser to the negative filament line. Then, starting with the R.F. tube, wire up the remainder of the circuits going to each socket in turn—completely—before proceeding to the next; in other words, wire up the circuit in the same sequence as a signal proceeds through it, and the chances of making a mistake or leaving something out are then greatly minimized. Be sure, also, that the shield can of the R.F. choke, L1, is grounded.

Keep all leads as short and direct as possible and be sure to make good soldered joints. Perhaps some of you who have followed this series grow tired of this constant repetition of the advice to make good soldered joints and the insistence on a definite plan and sequence in construction; but rest assured that no single factor makes for smooth and consistent performance of radio equipment more than solidity, and no single factor helps to prevent mistakes more than systematic methods of doing things.

## Operation

After you are sure that every wire is in its place, and its correct place, plug in the tubes and attach the "A" battery; (Continued on page 614)

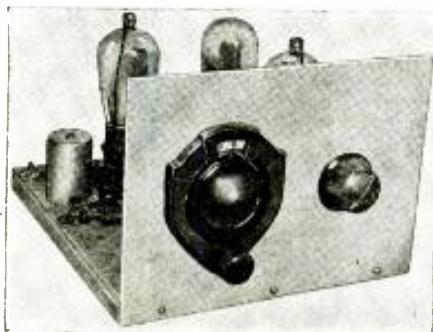

Fig. A  
Front view illustrating panel layout.

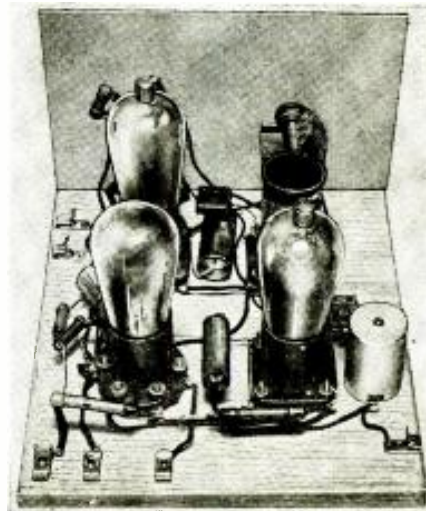
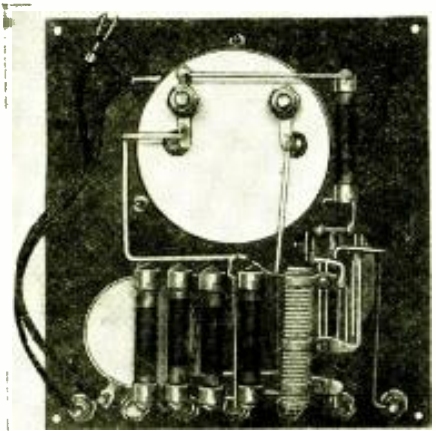

Fig. B  
Rear view showing location of parts.

# THE KNOCKABOUT TESTER

JACK GRAND\*



Rear view—showing assembly

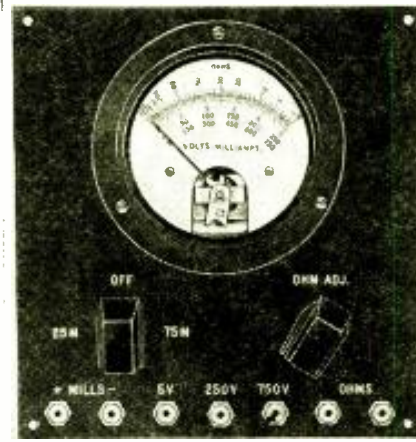

Front view of unit

THERE ARE occasions when a Service Man or an experimenter would like to use a compact and inexpensive volt-ohm-milliammeter in place of his regular tester. Many reasons can be advanced for this desire; such as a lack of space, or that the test does not require extreme accuracy, or the fact that one or two tests are to be made in a hurry.

The knockabout tester was designed to meet these demands, and supplies the following ranges:

- D.C. V. .... 0-5, 250 and 750
- D.C. Ma. .... 0-25 and 75
- D.C. Resistance ... 0-200,000 ohms

\* Chief Engineer, Sun Radio Co.

It is fortunate that lately, some manufacturers have released inexpensive 1 ma. meters. These meters are guaranteed by the manufacturers to have an accuracy of 2 per cent, incorporating various voltage ranges at 1000 ohms per volt.

The meter selected was a Beede 1 ma., 3/4 in. meter, having an internal resistance of 50 ohms and is furnished with a scale that allows for the ranges described.

The resistors used as multipliers are of the metallized type that the average Service Man has in quantities. If the resistors are purchased from good manu-

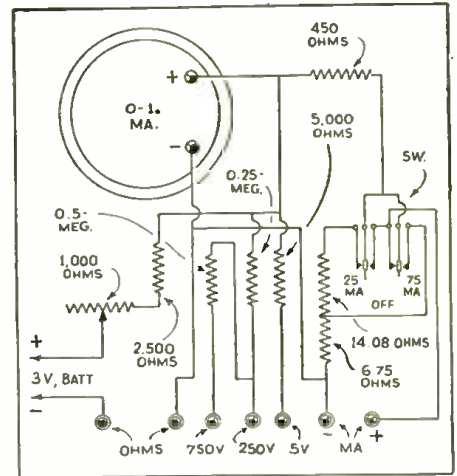

Schematic circuit of the tester

facturers, some can be selected that may be within 2 per cent accuracy, and will maintain this accuracy for a reasonable period of time.

For current readings, an Electrad 10 W. wire-wound resistor with an extra clip was used. To make calibrations easier, a resistance of 450 ohms was placed in series with the meter. Therefore, the shunt resistance for the 25 ma. (Continued on page 626)

## A COMBINED P. A. AMPLIFIER AND BROADCAST TUNER

PART II

LEON J. LITTMANN\*

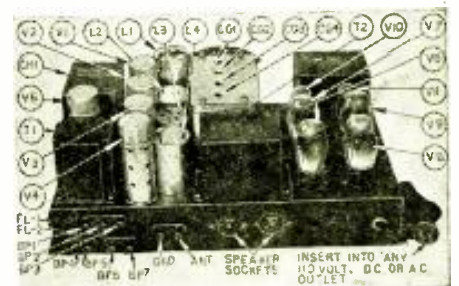

Fig. 3  
View showing layout of equipment

UP TO THE present time it has been practically impossible to place the phono-microphone matching transformer on the same chassis as the power amplifier and power pack proper, without introducing an objectionable hum into the loudspeaker. This was invariably the case, due to the impracticability of shielding the input transformer well enough from the strong magnetic fields of the power transformer. However, this unit does not use a power transformer.

The universal input transformer, T1, has not only a winding for a double-button or two single-button microphones, but also has a high-impedance phono. winding, BP4, 5, 6 and 7, of 3,000 ohms, tapped at 500 and 200 ohms, to permit the use of practically any phono. pickup or line. In other words, any phono. pickup may be connected directly to this universal input transformer. The vari-

ous input impedances permit any phono. pickup to be correctly matched, enhancing thereby the possibility of distortion-free and life-like reproduction with maximum gain. Similarly, a double-button microphone, or two single-button microphones may be correctly matched when connected to the corresponding binding posts BP1, 2, 3, after a 3 or 4 1/2

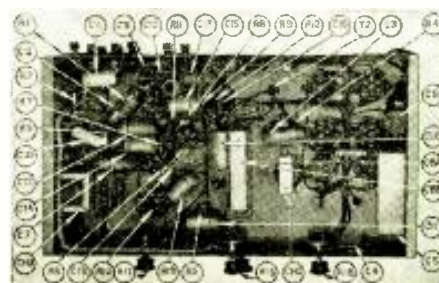

Fig. 2  
Internal wiring and layout

V. "C" battery is connected to the two flexible extension leads FL1, FL2. No precaution in respect to polarity needs to be taken. The input signals to the phono-microphone amplifier are fed from the universal input transformer through a .5-meg. tapered attenuator, R16, directly into the grid of the first triode section of the 79 tube. Its plate, P1, is resistance-capacity coupled to the second triode (contained within the same glass envelope) of the 79 twin audio tube. As these two triodes have a common cathode and cathode resistor, the bypass condenser across it, C6, should be a 50 mf. 25 V. electrolytic condenser to prevent the 79 tube from breaking into oscillation. Switch Sw.1 and R16 are ganged, and when snapped on the switch (Continued on page 630)

\* Chief Engineer, Coast-to-Coast Radio Corp.





# A DIRECT-COUPLED P. A. SYSTEM

A complete and efficient rental or demonstration portable 10 W. push-pull set-up.

HUBERT SHORTT\*

**W**ITHIN the past few years, the demand for portable systems has increased tremendously. Many radio Service Men have taken advantage of this situation, increasing their profits to a point where

\* Chief Eng'r, Wholesale Radio Service.

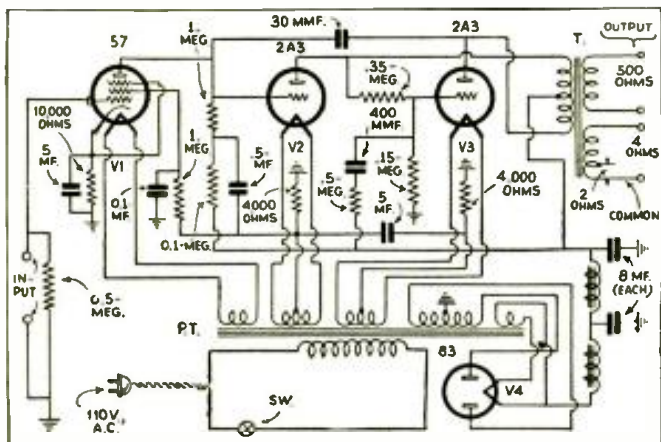

Fig. 1  
The schematic wiring diagram of the amplifier

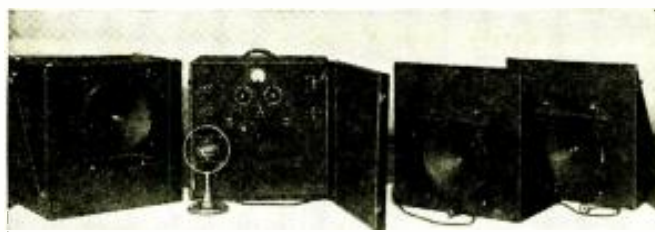

Fig. A  
The complete equipment of the portable P.A. system

they were able to specialize in this particular field and leave the less profitable types of work to slow-moving competitors.

Right now, the market is still wide open and there is no excuse for delay in getting started. Portable P.A. systems are required by lecturers, vaudeville acts, political speakers, fraternal orders, for demonstrations of all kinds, etc. Once a demonstration of a P.A. system has been made, a sale is readily assured. No special knowledge is required.

Modern P.A. systems are fool-proof and are exceedingly easy to operate. The particular system described here has been designed especially for use wherever a compact and portable P.A. outfit is required. Due to its compactness and light weight, it may be moved quite easily from place to place. Its output of 10 W. permits it to be used in theatres, dance halls, and for outdoor gatherings up to 3,000 people.

The complete system is built into two handy cases, one of which contains the amplifier and mixing panel, and the other two dynamic speakers to assure adequate sound distribution.

The mixing panel incorporates a master switch with pilot light, a mike current control, a Weston mike current meter, two jacks for breaking into either button line for measuring button current, a master gain control, a tone control and a phono-mike changeover switch. All connections—microphone, phono. pickup and speakers—are made from the front of the panel. In this way, complete control is available di-

(Continued on page 614)

# ARE HEADPHONES COMING BACK AGAIN?

**I**T seems that radio fads or fancies are cyclic in that Mr. John Radio Public is bringing back into use receiver instruments that have gone out of popularity some time ago—at least where headphones are concerned. And the reason for the present resumed popularity of these ear clamping devices is obvious when we consider the renewed activity of DX fans. The possibility of obtaining remote stations by means of short-wave reception, the improved efficiency and increased power of present day broadcast stations, more sensitive and improved receivers, are all the potential reasons for the reincarnation of the "distance getter" and consequently the

motivating force behind the increase in sales of headphones.

Distance can best be received in the early hours of the morning, even on short waves. This is due to the time difference that exists where stations are remotely located from the receiver, and also due to the "signing off" of local stations (most of them, anyway) around midnight, which removes station congestion all over the receiver dial, and as a result permits going after out-of-town reception. However, there's the wife, baby, or rest of the family to consider, whichever the case might be, and so phones must be used unless an anesthesia is administered to those who retire early so that they might not be disturbed later. Then again, some signals will be received very feebly, necessitating the use of phones if the program or the station call letters is to be heard clearly.

Not all sets have provision for this item, due to the waning popularity of phones in the past few years, up until this time. While there are many who have a sufficient knowledge of radio circuits and are therefore able to make the necessary circuit changes and additions, there are still a considerable number



who are not equipped with this knowledge, or still another class who would hesitate to make any alterations on their receiver for fear that the changes might in some way diminish the efficiency of the set. While there is no real ground for fears of this nature—providing the slight changes necessary are done properly, nevertheless there is no need for all this work since there are many devices or "adapters," now on the market.

One of these units that is very much different from the conventional type and

(Continued on page 626)



This adapter, while slightly larger than the average, incorporates added features.



# THE ANALYSIS OF RADIO RECEIVER SYMPTOMS OPERATING NOTES

## WHAT THIS DEPARTMENT IS FOR

It is conducted especially for the professional Service Man. In it will be found the most unusual troubles encountered in radio service work, written in a practical manner, by Service Men for you.

Have you, as a professional man, encountered any unusual or interesting Service Kinks that may help your fellow workers? If so, let us have them. They will be paid for, upon publication, at regular space rates.

## CROSLLEY 124

A CROSLLEY model 124 presented the greatest number of ills heretofore encountered in any one particular radio set. The most prominent ailments appeared to be lack of volume, persistent fading, and a rasping reproduction of sound with frequent low-frequency howls.

A voltage analysis disclosed abnormal plate and screen-grid voltages on the R.F. and I.F. tubes. This trouble was traced to an erratic 15,000 ohm resistor feeding this section.

The fading was then traced to the condenser block containing four .1-mf. bypass condensers. Replacing one section at a time, the entire unit in this case had to be replaced before the fading subsided.

And so, by the process of elimination, all that remained to be remedied was the faulty reproduction and accompanying howl. Since this was obviously caused by the dynamic speaker, this member was put into operation in a dark room for observation. (Examina-

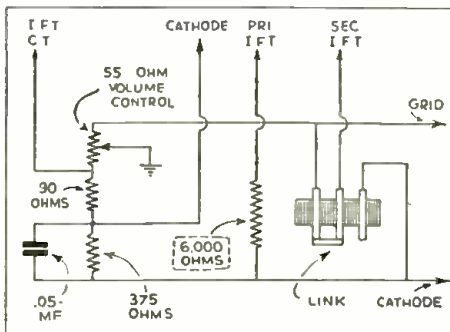

Fig. 2  
Overcoming low volume in Radiola 66.

tion of the voice coil had previously disclosed the cause of the rasping sound to have been a "rubbing voice coil," but eliminating this defect failed to cure the howl, therefore the "dark-room" experiment. Even though the voice coil appeared to be perfectly centered, a series of tiny sparks were seen each time a howl occurred. This same kind of howl could be simulated by allowing one of the bare voice-coil leads to intermittently touch the speaker chassis, thereby creating a low-frequency buzzer action. A more careful examination of this voice coil revealed the cause of the entire difficulty to be in a distorted coil. The innermost end of the coil-form proved to be larger in diameter than elsewhere along its length. During the coil's outward excursion, when reproducing a tone of low-frequency, the above mentioned buzzer action would take place with its resultant howl. A new cone replacement overcame this difficulty and made the set perform normally.

## PHILCO 30

SINCE the bakelite encased condensers manufactured and used by Philco in their battery and electric models appear

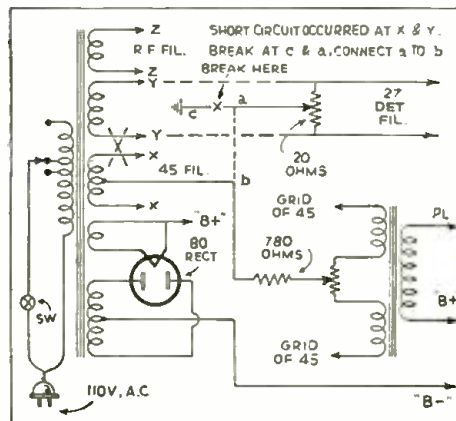

Fig. 3  
Removing hum and distortion in Edison R4-R5.

to be such persistent offenders, it naturally follows that an initial check-up of these units is not amiss, usually resulting in the discovery of the offender.

The battery model Philco 30 is no exception to this rule. When radio signals do the disappearing act in this model, i.e., fade out regularly, the trouble can nearly always be traced to one or more of the .05-mf. blocking condensers in the R.F. stages, most often the first as indicated in the accompanying schematic part-circuit diagram, Fig. 1. The offending unit can usually be made to "act-up" by exerting a slight pressure on one or the other of its connector lugs with the set in operation. A proper replacement obviously effects the cure.

## RADIOLA 66

A LACK of volume in the Radiola 66 superhet. can often be traced to the red and yellow bleeder resistor connected (as indicated in Fig. 2) to the primary of one of the I.F. transformers. (Continued on page 622)

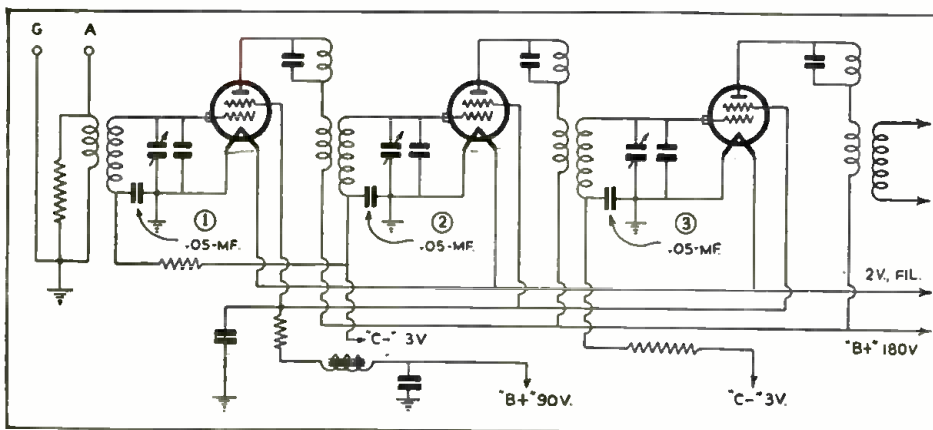

Fig. 1  
Intermittent reception in Philco 30's is sometimes caused by defective bypass condensers.

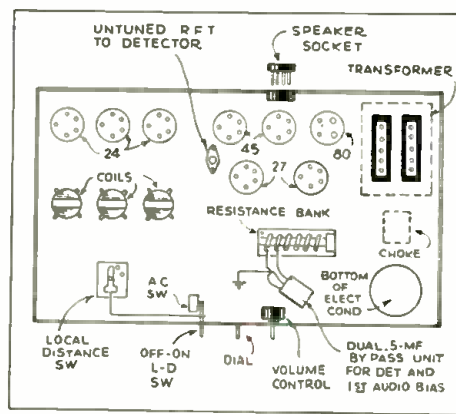

Fig. 4  
Crosley 42's, dual bypass unit causes grief.

RCA VICTOR MODEL 261, 555 TO 107 METER, DUAL-RANGE, 10 TUBE SUPER.

(Incorporates tone-compensated volume control; A.V.C.; interstation noise suppression; push-pull A.F.; electrostatically-shielded power transformer; and individual treble and bass tone controls.)

A frequency-range switch is the top control. Turn it clockwise for the 540 to 1,500 kc. broadcast band; using the range numerals, the dial scale reads directly in kc. for this band. Turn clockwise for the 1,400 to 2,800 kc. bands (services 1, 2 and 3, below); using the small numerals at the bottom of the dial, add 2 ciphers to obtain the kc. reading. The three services mentioned above are as follows: (1) police calls—1,574 to 1,712 kc., and 2,400 to 2,500 kc.; (2) amateur phone—1,800 to 2,000 kc.; (3) aviation phone—2,500 to 2,800 kc. (Strong local stations in the broadcast band may be sometimes heard at more than one point on the dial, when the frequency-range switch is set for the 1,400 to 2,800 kc. band.)

At the lower left of the panel is the silent-tuning control; next, right, the bass and treble tone controls; and, extreme right, the combined off-on and volume control.

With the silent-tuning control set in the extreme counter-clockwise position tune to a point at which no station is heard within several scale divisions, then turn the silent-tuning control clockwise until the background noise just disappears. This adjusts the inter-station noise suppression circuit.

Next, without touching the silent-tuning control accurately tune the receiver to a desirable program and adjust the volume control to a fairly low value. Then, tune the receiver accurately to a position midway between the points on the dial at which the program becomes unintelligible or disappears. Finally, re-adjust the volume control for the desired sound level and vary the two tone controls to obtain the desired tone shading.

To reduce the high-frequency (treble) response, or to decrease the background noise interference on station settings, turn the right-hand or treble-control knob counter-clockwise. To reduce the low-frequency (bass) response, or to decrease low-pitched hum present on the signals of some stations, turn the left-hand bass-control knob clockwise.

All resistance values, including those of coils, are shown in parentheses.

Tube operating voltages are as follows. The voltages are read with the volume con-

trol at minimum, no signal being received, and a line potential of 120 V.

Tube Type	C.G. Volts	S.G. Volts	Plate Volts	Plate Ma.
V1	3	100	230	7
V2	8	95	220	2½
V3	—	—	105	6
V4	7½	100	225	2½
V5	7½	100	225	2½
V6	20	—	0	—
V7	17	—	250	1.2
V8	18	255	245	33
V9	18	255	245	33

The recommended outdoor antenna length for this receiver is from 25 to 75 feet, including lead-in and ground wire.

The power consumption of this set is 120 W. The undistorted power output is 4 W.

Four adjustable condensers are provided for aligning the R.F. and oscillator circuits. Lack of alignment may result in poor tone quality, insensitivity, poor A.V.C. action, and possible inoperation of the receiver. To align the R.F. circuits use a service oscillator having A.P. modulated signals of 600, 1,400, and 2,440 kc. The output meter may be a current-squared galvanometer connected to the secondary of T2 instead of the voice coil; a 0.5-ma. meter connected in the plate supply circuit of V7; or, a low-range A.C. voltmeter connected across the reproducer voice coil. Plug a dummy, type 56 tube (a "good" 56 from which one heater prong has been removed) in place of V6.

First check the chassis and carefully ascertain that the dial pointer reads exactly at the first line on the scale when the rotor plates of the tuning condenser unit are fully meshed. Then, couple the 1,400 kc. output of the service oscillator to the antenna connection, turning the range switch counter-clockwise and setting the dial exactly at 1,400. With the output meter connected to the set, place the volume control and suppressor control, if noise level will permit, at its maximum position and adjust the oscillator input for a moderate output meter reading. Adjust the circuits of V3, V2 and V1, in this order, for maximum deflection of the output meter.

To align the high-frequency band, adjust the service oscillator to 2,440 kc., set the dial at 1,200, and turn the range switch to

the clockwise position; align the condensers on the selector switch for maximum output meter reading.

Now, set the service oscillator at 600 kc. and align C9 for maximum deflection of the output meter while rocking the tuning condenser gang back and forth.

A similar series of procedures is to be followed with the service oscillator adjusted to 1,400 kc., to complete the alignment of the R.F. circuits. Note that I.F.T.2 is untuned. The tuned I.F. transformers are broadly peaked.

Still using an output meter, and a dummy type 56 tube, couple the 175 kc. output of the service oscillator to the control-grid of V2 and to ground, after having removed V3 from its socket. The chassis should be connected to a good ground. Adjust the oscillator output for maximum output meter deflection, with the receiver volume control at maximum. Adjust the I.F. trimmers in the following order: C22, C21, C15 and C14; repeat this series of procedure until maximum deflection of the output meter is obtained.

Due to the inter-locking of adjustments it is good practice to follow the I.F. adjustments with the R.F. and oscillator adjustments.

Do not apply power to this receiver until all the tubes are in place. Make certain that all the tube shields are rigidly in place. Also, check the spring connectors of the short, flexible (control-grid) leads and make sure that they are securely attached to the dome terminals of the correct tubes; it is important that the adjacent green and black leads be connected correctly—that is, not reversed. The shield-can lids must be securely in place.

The resistors on the resistor board are placed on this board in the following order: R25, R26, R11, R12, R13, R7, R2, R4.

Note that the tuned secondary of L3 is permitted to "float" without connection to any other part of the circuit, and results in extreme frequency stability.

The audio system of this receiver merits special consideration. If it becomes necessary to replace any of the components, extreme care should be taken to use high-quality replacement components of exactly the specified values.

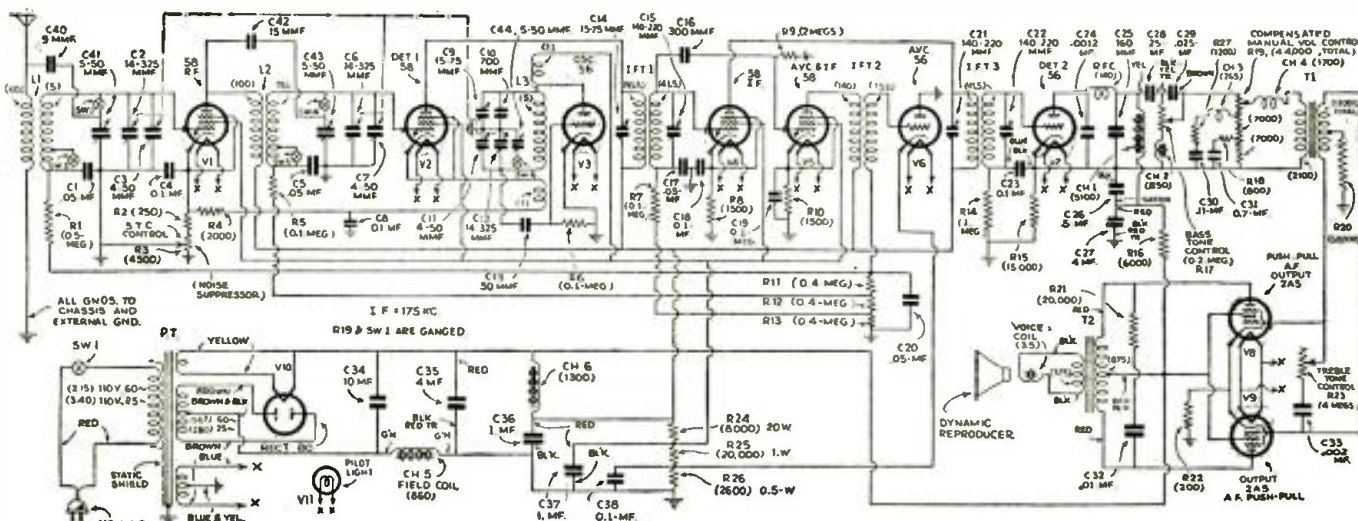



EMERSON MODEL 678 "AUTO-DYNAMIC" 5 TUBE SUPERHETERODYNE

[Incorporates delayed A.V.C.; push-pull A.F. amplification; full-wave, tubeless "B" supply; tone control; automatic tone-compensated volume control; interstation noise suppression.]

Recommended as a self-contained automobile and motorboat superheterodyne receiver, this set has a sensitivity of less than 1 microvolt-per-meter; the battery drain is only 4.8 A. The maximum output is 4 W. Following are the voltage readings for this receiver, all voltages being measured to ground:

Tube Type	Cath. Volts	S.-G. Volts	Plate Volts
V1	3.25	80	205
V2	3.25	80	205
V3	4	80	205
V4	16	205	195
V5	16	205	195

Use a high-resistance voltmeter. The figures given are average values taken with a fully-charged storage battery and with no signal being received. The field coil has a resistance of 6 ohms; the potential across the coil is 6 volts.

If the positive terminal of the storage battery is grounded no changes are necessary in the receiver when making the initial installation. If the negative terminal of the battery is grounded a slight change in the receiver connections is necessary. Remove the top screw and loosen the bottom screw holding the serial number plate to the right side of the receiver cabinet. Tip the plate down and reverse the red-and-black-marked spade lugs so that the black-marked lug will be on the top, and the red-marked lug will become the lower one. Test for battery polarity by using a low-reading D.C. voltmeter. When connecting the twin-conductor, shielded cable to the battery the black wire always connects to the grounded terminal of the battery, and the yellow wire to the "hot" terminal, regardless of battery

polarity. Ground the cable as often as possible along its entire length, and run the cable as far as possible from the engine compartment and all wires which might act as interference carriers.

Noise suppression resistor R1 is adjusted at the factory for minimum suppression. If the interstation noise is considered too high (this may be determined best by tuning in an average station at a setting of average volume, then detuning the dial slightly, without touching the volume control setting, so that no signal is received), adjust R1 clockwise sufficiently for best interstation noise suppression. Adjustment beyond this point may desensitize the receiver to weak stations although not affecting strong ones.

Tone control R2 is adjusted at the factory, for full-register reproduction, to the best setting recommended for reception of local programs in closed cars; turning the control clockwise brings up the low tones and is recommended for the reception of musical programs in open cars (incidentally, the position recommended for the reduction of static, and other high-frequency interference).

Do not adjust R2 clockwise more than necessary as definition of speech may be lost due to the attenuation of the higher frequencies caused by the acoustic characteristics of the interior of the car. To align the I.F. circuits connect the oscillator output to the control-grid cap of V1 and the chassis; connect a rectifier-type output meter across the voice coil of the speaker or the primary of T1. Then, ground the antenna lead, and turn the tuning dial so that the only signal received, with the volume control at maximum, is that of the service

oscillator. Align for maximum output, using a non-metallic screwdriver.

To align the R.F. section couple the oscillator to the antenna lead and chassis. Align for maximum output, using a weak signal of about 1,400 kc.; re-align the trimmers once or twice.

A slight buzz or vibration of the "B" unit when in operation is normal; lack of this characteristic may indicate a fault in the unit (in which case the output voltage should be checked).

The fuse in the remote control unit is a 10 A. unit. If it burns out, determine the cause before replacing it.

In previous DATA SHEETS and elsewhere in past issues of RADIO-CRAFT, the suppression of car radio noise has been given detailed consideration. The following data supplements this information. Interference may be generally classed as (1) body noise; (2) brake static; (3) hash. Body noise may be checked by permitting the car to coast with the motor shut off. Eliminate the fault by tightening all body bolts and bonding metal parts which are not thoroughly grounded. Brake static is a peculiar noise developed in the brakes and can be eliminated by cleaning and adjusting the brakes, and bonding all metal parts which are not thoroughly grounded. Hash is a term applied to interference caused by vibrator-type "B" units. It may be picked up by either the antenna of the set, or the set cables. Complete shielding and frequent bonding of the antenna lead-in will eliminate this type of interference.

Coils L3 and I.F.T.1 are a composite unit. The condenser furnished with the noise suppression kit is a 5 mf. unit.

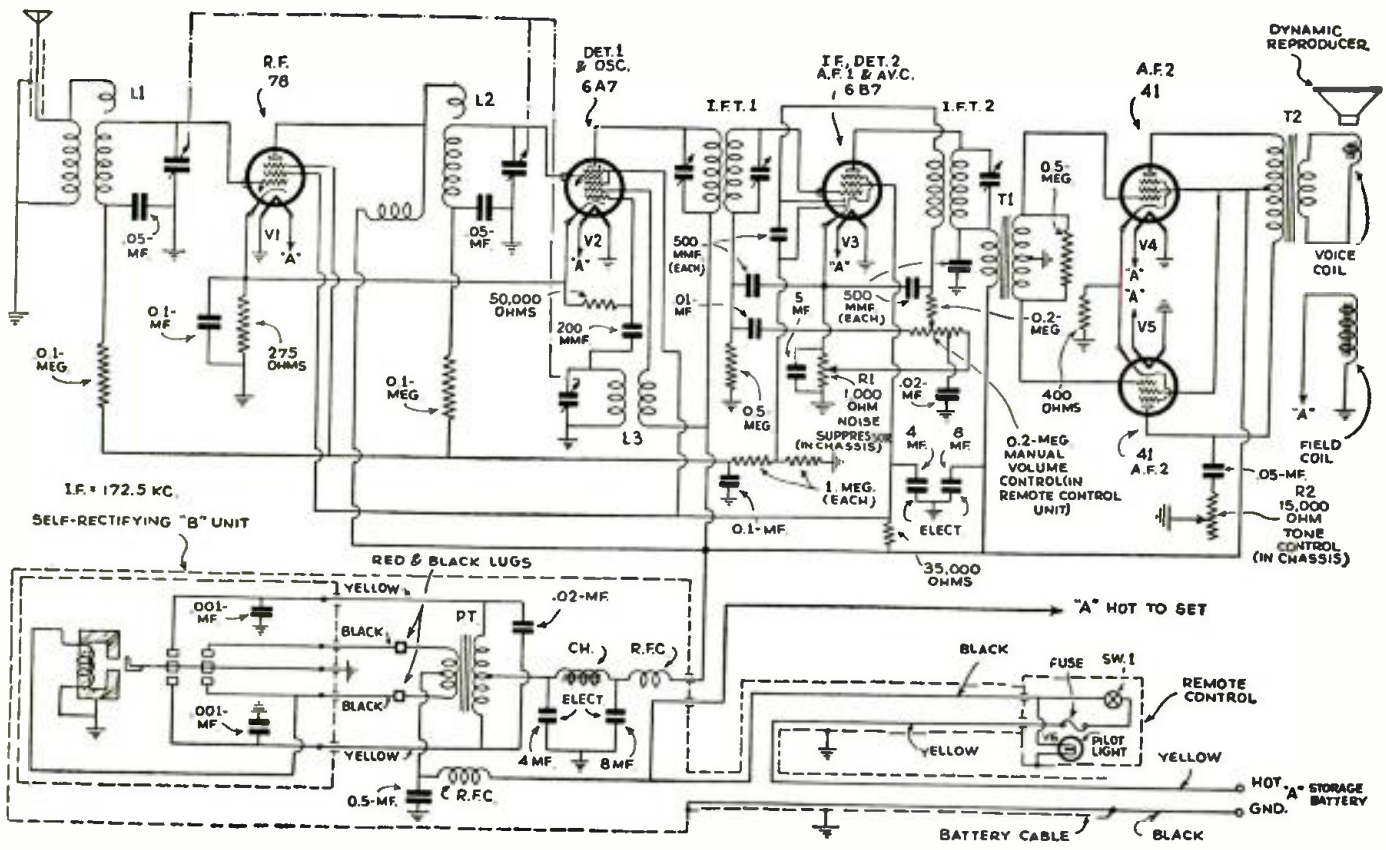

# RADIO-CRAFT'S INFORMATION BUREAU

SPECIAL NOTICE TO CORRESPONDENTS: Ask as many questions as you like, but please observe these rules:

Furnish sufficient information, and draw a careful diagram when needed, to explain your meaning; use only one side of the paper. List each question. Be SURE to sign your name AND address.

Those questions which are found to represent the greatest general interest will be published here, to the extent that space permits. At least five weeks must elapse between the receipt of a question

and the appearance of its answer here.

Replies, magazines, etc., cannot be sent C. O. D.

Inquiries can be answered by mail only when accompanied by 25 cents (stamps) for each separate question; answers are subject to subsequent publication, if considered of exceptional interest.

Other inquiries must be marked "For Publication."

## "TREASURE LOCATOR"

(249) Mr. L. C. Wright, Springfield, Ohio, (Q.) Although I have carefully built up the "treasure locator" described in the July, 1933 issue of RADIO-CRAFT, and checked over the instrument as per the additional information in the Information Bureau of the November, 1933 issue, the device seems to lack sensitivity. Can you make any further suggestions?

(A.) We are fortunate in being able to print below the following interesting letter received from Mr. Iven Gill of Pueblo, Colo. Although the directions published in the July and November issues of RADIO-CRAFT have been given official sanction by Mr. Server, the following reference data may prove useful in checking the operation of balky models.

"Having built the metal locator described in the July, 1933 issue of RADIO-CRAFT and not being successful in getting my apparatus to function in the floating oscillator circuit shown, I rewired the circuit slightly as shown in Fig. Q.249. When completed, using this Hoffman balanced Colpitts circuit, the outfit worked satisfactorily on first trial, "detecting" metal at a distance of 6 feet in the open air and in the ground at a distance of about 3 feet! The general construction and mounting of parts remains the same as in the original article; I have not tried the later circuit given in the November, 1933 issue."

## "THE 'PHONOSONE'"

(250) Mr. J. A. Parrisch, Baton Rouge, Louisiana.

(Q.) Is the Osophone a practical device for use as a deaf aid? (This instrument is designed to be gripped by the teeth of a person who is hard of hearing, its vibrations being "heard" through the teeth.)

(A.) Although the Osophone as originally designed functioned very satisfactorily it was inconvenient to use it and for that reason the "Phonosone" has been designed; a description of this later unit has been published in the March, 1934 issue of RADIO-CRAFT. For those who may be interested in experimenting with this idea there are given in Fig. Q.250, two improved circuits for connecting the Phonosone to the radio set.

At A are indicated the connections for a

single output tube; and at B, the diagram to be followed if the output tubes are in push-pull. When the switch is in position *a*, only the "unit" is being used; at *b*, only the regular dynamic reproducer in the set is used; in neutral position *c*, both units are inoperative. The switch is of the 12 leaf, 3 position, anti-capacity type.

## REVAMPING OLD SETS

(251) Hawley Fleming, San Francisco, Calif.

(Q.) As I would like to rebuild a Sparton model 40 automobile radio set for greater sensitivity and volume, kindly furnish all information regarding the necessary resistors, condensers, and applied voltage values to use the following tubes. In place of the original type 26 tubes, I would like to use the type 39, and two type 89 tubes in push-pull in place of the 38.

(A.) To successfully incorporate the tubes mentioned it would be necessary for you to obtain an entirely new set of coils, tuning condensers, resistors and fixed condensers. The cash outlay and labor involved would outweigh the improvements that might be secured.

## TYPE 58 TUBE

(252) Mr. Louis Giordana, Arlington, New Jersey.

(Q.) Isn't there some mistake in the connection of the type 58 tubes in the diagram of the "Ultra-Modern Super" shown in the October, 1932 issue of RADIO-CRAFT? A schematic shows the suppressor-grid connected to the cathode internally, whereas, the tube data in the July, 1933 issue shows the connection to be external. I have made a continuity test between cathode and suppressor-grid and there is no connection.

(A.) The suppressor-grid connection of the type 58 tube should have been shown as being made external to the tube, as indicated in the RADIO-CRAFT Tube Chart to which you refer.

## SUBSTITUTING TUBES

(253) Mr. Arturo E. Govin, Habana, Cuba.

(Q.) I beg to refer to your editorial published in the January, 1934 issue of RADIO-CRAFT, suggesting the substitution of the type 27 tubes by the new 56; and, the type

24 tubes by the new 57 or 58 tubes, and others.

In the first place, I hardly see how a tube of higher plate voltage can be used instead of one of lower plate voltage as is the case with the new 57 tube and the old 24 tube. The same applies to the new 56 tube in connection with the old 27 tube. Consequently, I do not think such substitution could be done in a receiver using three type 24 R.F. tubes and one 27 as detector, as we would have available only 180 V. and 90 V. plate voltage, respectively, and if we would like to use three 57's as R.F. and one 56 as detector, we would need to have available 250 V. plate voltage in both cases.

Furthermore, in using the new 57 instead of the old 24 there is an additional connection to be made—the S.G. prong of the 57, which you do not indicate in said article. I presume that this additional connection of the 57 (S.G.) should be made to the cathode of the tube or to chassis, for I understand that leaving open this lead the new tube would be inoperative.

I would highly appreciate your suggestions in connection with the points above referred to.

(A.) In the first place, the editorial was not intended as a technical presentation but merely as a suggestion as to what can be done. The types 56, 57 and 58 tubes are rated at 250 V. on the plate. This does not necessarily mean that you cannot apply less than this amount. If you have 180 V. available this may be applied with excellent success, even though the label on the tube says "Plate Voltage, 250."

In using the 57 instead of the 24, the additional grid should be tied directly to the cathode of the tube, remaining connections being the same.

In connecting these new tubes, of course, you must be familiar with their ordinary usage and arrange your circuit so that it can be accommodated.

## "MEGADYNE 'N'"

(254) Mr. G. T. Her, Fanwood, N. J.

(Q.) I have notified with keen interest the circuit and description of the Megadyne "N" receiver described in the April, 1933 issue of RADIO-CRAFT. I notice that the tickler coil you state is connected in the screen-grid circuit, while the circuit shows it connected in the control-grid circuit. Which is correct?

(A.) The correct connections of the Megadyne circuit are as they appear in the schematic diagram. (Continued on page 620)

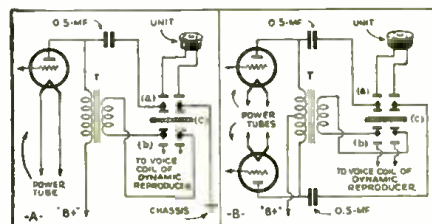
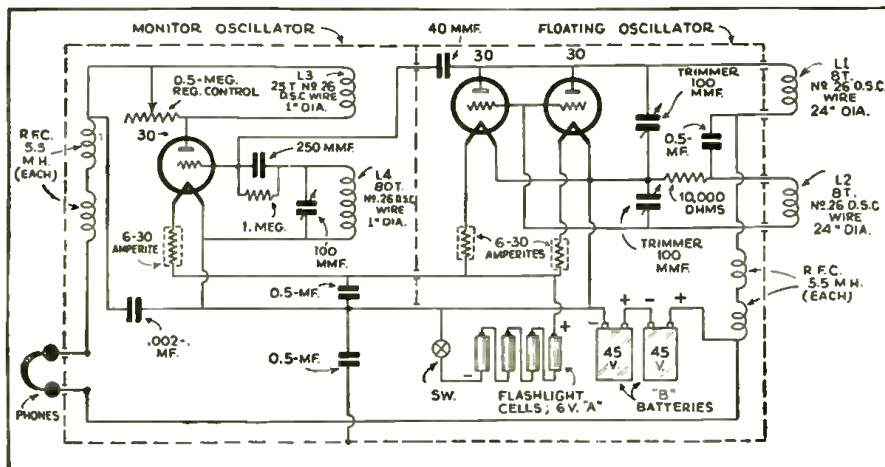

Fig. Q.249 On the left, an improved floating oscillator for "Treasure Locator," to increase sensitivity.

Fig. Q.250 Above, improved circuits for connecting the Phonosone to sets using 1 or 2 output tubes.





**\$3.50**

Reg. List Price

400 Pages  
Over 2,000 Illustrations  
9 x 12 Inches  
Flexible, Looseleaf  
Leatherette Cover

## There's plenty of Servicing Material in the **NEW 1934 Manual**

**T**HE necessity of GERNSBACK Manuals in the radio field has been shown by the fact that the total sales of the first three OFFICIAL RADIO SERVICE MANUALS, including the new CONSOLIDATED EDITION, now exceed 80,000 copies. Radio Service Men and others engaged in various branches of radio know the importance of such books, and how they must depend upon them for reliable information. Whether for public-address work, tube information or a circuit diagram, the material needed is certain to be found in one of the OFFICIAL RADIO SERVICE MANUALS.

In preparing this new edition many of the outstanding problems of the Service Men have been considered—methods of servicing, the new equipment constantly needed to cope with new tubes and sets, and the other fields of radio, such as public-address systems, short waves, auto radio and others.

The illustrations in the 1934 Manual are more explicit than before; inasmuch as the diagrams are not limited to the schematic circuit, but other illustrations show the parts layout, positions of trimmers, neutralizers, etc. There are hundreds of new circuits included, and not one from any previous editions of the manuals has been repeated. *This we unconditionally guarantee.*

As in previous years, the 1934 Manual also includes a FREE QUESTION AND ANSWER SERVICE. In each book will be found 25 coupons, which entitle you to free consultation on any radio service topic. These coupons give you a complete mail service—questions on servicing and operating any set or circuit are answered promptly and accurately by the editors. Remember that, at the regular rate of 25¢ per question which is usually charged by radio magazines, this service alone is worth \$6.00. And for the Manual, we charge only \$3.50.

It is quite evident that the 1934 Edition of the OFFICIAL RADIO SERVICE MANUAL is a decided improvement over previous volumes.

### ORDER YOUR COPIES NOW

It is important to every Radio Service Man and Dealer to get his copy of the 1934 OFFICIAL RADIO SERVICE MANUAL now. The new book will prove itself to be invaluable as those volumes of previous years.

No need to delay sending us your order—the 1934 MANUAL, like its predecessors, is a necessity in your business. We strongly advise you to order your copy today.

**GERNSBACK PUBLICATIONS, INC.**  
96-98 Park Place New York, N. Y.

### Contents of the 1934 Manual in Brief

- Diagrams and service notes, more complete than ever before in any MANUAL. Not merely the schematic hook-ups will be found, but chassis drawings showing parts layouts, positions of trimmers, neutralizers, etc.
- Voltage readings for practically all sets, as an aid in checking tubes and wiring.
- All values of intermediate-frequency transformers used in superheterodynes, with the manufacturers' own suggestions as to correct balancing.
- Detailed trouble-shooting suggestions and procedure as outlined by the manufacturers' own engineers—in other words, authentic "dope" right from headquarters.
- Values of all parts indicated directly on all diagrams.
- Section for reference to A.C.-D.C. cigarbox midsets.
- Section for reference to public-address amplifiers.
- Section for reference to short-wave receivers.
- Section for reference to remote-control systems.
- A complete compilation of radio tube data, covering both the old and the many new types.
- Section devoted to test equipment, analyzers, etc., with full diagrams and other valuable information.
- A complete list of American broadcast stations with their frequencies in kilocycles; extremely useful in calibrating and checking test oscillators and in calibrating receivers.
- Free Question and Answer Service, the same as in our last two Manuals.
- No theory; only service information in quickly accessible form.
- Absolutely no duplication of any diagrams; nothing that appeared in any of the previous Manuals will appear in the 1934 MANUAL. This we unconditionally guarantee.
- A handy, easily-consulted master index making it easy for you to find almost anything pertaining to your service problem instantly. This index includes all the diagrams published in all the previous GERNSBACK Manuals, as well as the 1934 diagrams. A big convenience and time saver!

### Clip—Mail This Coupon Today

GERNSBACK PUBLICATIONS, Inc.  
96-98 Park Place, New York, N. Y.

Gentlemen: Enclosed you will find my remittance of \$3.50 for which you are to send me, Postage Prepaid, One Copy of the 1934 OFFICIAL RADIO SERVICE MANUAL. [Send remittance by check or money order; or register letter if it contains cash, currency or unused U. S. Postage stamps.]

Name .....

Address .....

City ..... State .....

RC-334



## The new RADIOHM did the trick



Servicemen are "sitting pretty" since the new Radiohm was made available for replacements. Now even smoother performance is made possible while the control itself is made smaller. Stock up now . . . with the serviceman's best friend.



Resistor B of annular shape, has long been the standard type. Current concentrates around the INNER edge, i. e., the shortest path.



Resistor A used in the new Radiohm, has the same length path across its entire width, giving greater effective area for good volume control.

Your jobber has the new 1934 Volume Control Guide. Ask for it!

# Centralab

CENTRAL RADIO LABORATORIES  
MILWAUKEE WISCONSIN

## PRACTICAL RADIO ENGINEERING

An opportunity for RADIO MEN to enlarge their scope of training.

Whether elementary radio principles or advanced subjects, sound applications or practical radio engineering, RCA Institutes is prepared to give you the instruction you need.

RESIDENT SCHOOLS NEW YORK AND CHICAGO with modern standard equipment  
EXTENSION COURSES FOR HOME STUDY under convenient "no obligation" plan. Illustrated Catalog on Request

**RCA INSTITUTES, INC.**  
Dept. RT-4

75 Varick Street, New York  
1154 Merchandise Mart, Chicago

## BETTER Radio Parts

IMPROVE your short-wave construction with the world-famous Hammarlund Condensers, Coils, Chokes, Sockets and Shields. Backed by 33 years of engineering leadership.

Write Dept. RCA for FREE CATALOG "34"

HAMMARLUND MFG. CO.  
424 W. 33rd St. New York, N. Y.

For Better Radio  
**Hammarlund**  
PRECISION PRODUCTS

## H. F. ADJUSTMENTS

(Continued from page 593)

A.C. receivers with filament circuits operated in parallel or separated, the following procedure is recommended:

1. Turn on the receiver for regular operation and tune the set to a station somewhere above 1000 kc. Select a station giving low or minimum volume and adjust the volume control so that the signal will not be entirely eliminated by removing the 1st R.F. tube. If you can find no station with which to attain the adjustment, secure a modulated oscillator, connect its low-output terminal to the antenna post of the receiver, its ground post to the ground of the receiver and adjust the attenuator until the above conditions are realized; that is, the oscillator and receiver are tuned so that the set picks up its signal somewhere above 1000 kc.

2. Remove the 1st R.F. tube from its socket, place a small section of a drinking straw over one filament terminal (these are the larger terminals) and replace it in its socket. Some Service Men use a "dummy" tube having one filament prong detached or one having a burned out filament. Since such a tube may not have the exact internal capacity of the one which must be used in the circuit the first method is preferred.

3. Adjust the neutralizing condenser for the 1st stage, first one way then the other, carefully noting the signal volume as it will come through the tube capacity or the neutralizing capacity if the latter is not correctly adjusted. There will be one point in the adjustment of this condenser where the signal will entirely disappear, if there is no extraneous pick up from the circuit, and this is the correct neutralizing setting. Turn the adjusting screw one way until the signal can just be heard, then in the opposite direction, into the "null" zone until it can just be heard again. Finally adjusting to the exact half-way position between the two points.

4. Follow exactly the same procedure for every R.F. and I.F. stage in the receiver and neutralization will have been attained. To avoid extraneous pick up a distant station is usually tuned in, when fair volume is possible. The volume may be set at any convenient value.

### Alignment or Synchronization of Circuits

This information is equally applicable to T.R.F. and superheterodyne circuits and to all of the tuning condensers. To establish the theory and technique of this work clearly in mind we will consider the T.R.F. circuit first.

Each main tuning condenser whether there are 2, 3, 4 or 5 of them in the receiver will usually be provided with a small adjustable condenser in shunt with it and having about  $\frac{1}{4}$  to  $\frac{1}{10}$  its capacity value. In many cases one condenser of the gang will not be so provided as the other values will be adjusted to this one thus making it unnecessary.

Adjustments of these "trimmers" as they are called are made as follows:

1. Tune the set to a station near 600 kc., and if no station can be tuned from the lower tuning limit (maximum capacity) to about 1000 kc. setting, use a modulated oscillator tuned to 600 kc. or thereabouts. Ordinarily an oscillator will not be necessary for the average adjustment.

2. Turn the adjustment screw or nut on each condenser in any order for maximum signal output, reducing volume as desired, and noted by ear, as you go.

3. On sets having one trimmer for each tuning condenser—if one or more trimmers show a continuous increase in signal output up to maximum value beyond which the condenser cannot be adjusted—tune the main dial to a slightly lower frequency so that the signal volume is somewhat reduced (about  $\frac{1}{4}$  normal in your judgment) and reset all trimmers for maximum response once again. On models having one less trimmer than tuning condensers this procedure cannot be followed.

4. Now set the tuning dial to some station around 1000 kc. or if necessary use an oscillator as before and repeat adjustment of all trimmers. Little or no re-adjustment should be necessary.

## SERVICING "TALKIES"

(Continued from page 601)

after the show, and fix up next day's advertising copy together at home before they go to bed.)

It is thus a gentleman of very varied interests who must approve the plan of buying his sound supplies and service from the Service Man, instead of through whatever agency has been providing them in the past.

### The Manager of a Chain Theatre

Perhaps the majority of American theatres at the present time are operated as members of small chains comprising, roughly, from three to twenty or thirty theatres, all under one ownership or management. The extremely large chains, including hundreds of theatres, which were the rule a few years ago, have now broken down into these smaller units. Obviously it is far more profitable for the Service Man to deal with a chain, rather than a single theatre, if he can.

There are two ways to interest a chain of theatres; one is to visit its central office. The other is to secure the interest and approval of the manager of the local theatre of that chain.

The writer would suggest that the Service Man first approach his local manager and do business with him directly so far as he can. In this way the Service Man will soon learn, without asking, whether or not the theatre is a member of any chain, and, if so, to what extent the local manager is free to exercise his own judgment in matters of sound service and purchasing. The Service Man can then, if occasion requires, visit the chain's home office with the background of having served one of its theatres satisfactorily in some matters, as a sufficient justification for suggesting other services.

### Personnel of a Theatre Chain Office

The Service Man who has occasion to contact the district manager, or executive personnel of a theatre chain, can safely act on the assumption that the psychology of any of those men—with one exception—is that of any manager of an individual theatre.

But, there may be one exception. A chain may have a chief projectionist, or a purchasing official, or some other employee or partner who specializes in maintenance and is not a showman. Such a man can be recognized at once by the direct and well-informed interest he will take in the merchandise, prices and services the radio man has to offer. He will call tubes by their code numbers; he will not have to refer to his books to find out what he has been paying for them. There will be no necessity for employing any round-about methods of evoking his interest.

### What the Service Man Has to Sell

Everything that has been said so far in this series of articles constitutes no more than an unfortunately necessary preliminary to the meat of the matter: *what the Service Man has to sell*. Without such introduction some of the most valuable of the commodities he has to offer might not be understood by a radio man who happened to be unfamiliar with theatre practices. The list of the services the radio man can sell the manager includes the following:

- (1) Help in his advertising;
- (2) Help in his ballyhoo;
- (3) Equipment and parts of equipment, which the theatre now buys, very often at prices far below what the theatre is accustomed to paying, with a good margin of profit to the Service Man;
- (4) Equipment and parts of equipment, which the theatre now does not buy (tube testers, for example) for lack of a technician accustomed by daily habit to the use of such equipment;
- (5) Equipment and parts of equipment, which the theatre does not now buy (battery-replacement rectifiers, for example) for lack of a local technician willing to guarantee their installation and servicing;
- (6) Insurance against breakdown in the show;
- (7) Insurance against prolonged interruption of the show, if a breakdown does occur.

Sell the theatre one item of the above, please the manager and the projectionists, and you will probably be able to sell them the whole list.



# RADIO CONTROLS BATTLESHIP

(Continued from page 592)

portant in the case of actual battle, to operate guns, discharge torpedoes and operate the smoke screening apparatus.

The principle of distant control steering is simple enough. From a transmitting station, in the same way as in the ordinary wireless telegraphy system, signals of a definite wavelength and order of succession are sent off and taken up by the receiving apparatus of a radio-controlled ship. The weak impulses, when taken up by this receiver, actuate various relays, each of which will respond to only one signal. When the relay in question closes the electrical circuit, it automatically releases the rudder or other required motions.

Great difficulties, however, were encountered in carrying these principles into effect. Moreover, it was only possible to achieve this by combining them with additional means, namely gyroscopic motion. In course of development the gyroscope became the most important part of the intricate transmitting apparatus. Just as an auxiliary compass can be actuated by a gyroscope, so can an automatic ship-steering gear. This possibility has been recognized for years, the best known of such devices being manufactured by Vickers in England and for automatic control of hydraulic installations, in Germany.

In this automatic steering device the helmsman is replaced by a small electric motor. All that is required is that the navigating officer shall set the required course on the steering compass by means of a small wheel, the rest being effected by a small steering compass in conjunction with an electric motor. The latter revolves the formerly hand-operated steering wheel by chain transmission, the ship rudder being adjusted in the usual manner, either hydraulically or by telemotors.

Having evolved the automatic steering gear, the next step was to navigate from a distance. This, at present is done as follows: at the transmitter, the officer sets the required course which the radio controlled ship is to follow. Any momentum of the lever of the transmitting steering mechanism simultaneously changes the electrical contacts and, by this means, the various circuits which in their turn produce the special Morse signals. These signals are taken up by the receiver of the controlled ship, and they operate corresponding relays. The circuits thus closed, set the course indicator on the steering compass which then automatically performs its work. The machinery driving the ship is controlled in the same order of operation on the same principle.

After the steering of the unmanned ships had been mastered, great difficulty was encountered in manning their guns from a distance. Apart from the difficulties of automatic loading, the main problem was sighting and laying the guns (this problem in itself would have been solved had there been in existence any practicable and fool-proof television devices). However, after long experimentation the naval technicians developed a practical gun sighting and laying device which is comparatively simple in operation. In the fuselage of an aeroplane two transparent discs and other sighting arrangements are fitted. These two transparent and circular discs are marked with divisions each of which is numbered. An identical quadrant scale with similar divisions and numbers is fitted in the wireless-controlled ship. From an aeroplane an observer looks through the discs at the target below. The ship to be fired at comes within vision in one of the quadrants, say for instance in No. 4.

The observer sends off signal "4" to the controlling ship in which an officer adjusts the guns in the controlled ship by wireless to quadrant No. 4. The first shell is fired and simultaneously the observer watches (always through the discs) the drop of the shell.

If the shell drops close to the target, the splash would naturally appear in another quadrant of the disc—say in No. 5. He then signals "5" to the ship. The gun is adjusted by wireless to the correct range. Since, however, the aeroplane, the controlled ship, and the target are constantly changing their rela-

## Sound advice from STOOPNAGLE and BUDD

*They give a tip to every radio listener*



COLONEL, HERE'S A LETTER FROM A WOMAN WHO SAYS YOU HAVE A BAD VOICE, BUT IT'S NO WORSE THAN ANYBODY ELSE'S

GREAT—IN THAT CASE MY VOICE IS JUST AS GOOD AS THE GREATEST SINGER ON THE AIR



COLONEL, BE SERIOUS—THERE MUST BE SOMETHING WRONG WITH HER RADIO

RIGHT YOU ARE—I BET IT'S DISCONNECTED



SO YOU'RE READING MY LETTER, ARE YOU? WELL, I'LL TELL YOU, MY SET'S NOT DISCONNECTED

COLONEL, I THINK THIS WOMAN NEEDS NEW RADIO TUBES



SOUND ADVICE, BUDD—TO MAKE HER RADIO SOUND RIGHT SHE SHOULD REPLACE WORN-OUT TUBES

NEW TUBES—I NEVER THOUGHT OF THAT, MINE ARE OVER A YEAR OLD... I'LL HAVE THEM TESTED

### 5. 3 DAYS LATER—ON THE AIR AGAIN!



HERE'S THAT LADY AGAIN. I BET SHE SAYS YOUR VOICE IS WORSE

BUDD, I'M ALL CHOKED UP. JUST LISTEN: "I GOT A WHOLE NEW SET OF MICRO-SENSITIVE RCA RADIO TUBES... NOW I HEAR EVERY PROGRAM FINE"

## New! MICRO-SENSITIVE RADIO TUBES by

**RCA**

with 5 great advances:

- 1 Quicker Start
- 2 Quieter Operation
- 3 Uniform Volume
- 4 Uniform Performance
- 5 Every Tube is Matched

**TO GIVE YOU MORE RADIO PLEASURE**

Accept no substitutes! Get the genuine Micro-Sensitive RCA Radio Tubes with 5 great advances that will really put new life in your set. Only the new RCA Radio Tubes are guaranteed by RCA Radiotron Co., Inc., to give you these 5 great improvements. Have your dealer replace worn-out tubes today with these amazing new RCA radio tubes.

# RCA Lunningham Radiotron RADIO TUBES



**New Spring Supplement of 10000 Bargains!**

**FLASHING RADIO PRICES!**

**It SAVES money**

It's new... Hot off the Press! Every page is crammed with BARGAINS gathered from every part of the Radio Industry. Values greater than ever before—despite constantly advancing prices. If you have our catalog No. 55... you MUST have this SPRING SUPPLEMENT if you would keep up to date.

It lists last minute price reductions which have occurred since issuing catalog No. 55. It will keep you posted on Radio's latest developments and bring you added savings to supplement those found in our Big Catalog No. 55.

More than 10,000 items are listed at LOWEST WHOLESALE PRICES. Tubes, sets, kits, replacement parts, S.W. and Public Address equipment. This is NEWS that you cannot afford to miss... So get YOUR copy today... IT'S FREE!

**SOUND**  
ITS FUNDAMENTALS AND METHODS OF APPLICATION

**It MAKES money**

**a Profit-Making Book for the Service Man**

ENGINEERING DEPARTMENT  
Lafayette Radio Service Co.

Here is a book worth hundreds of dollars to you. A combination of salesman and catalog. Tells how, what and where to sell SOUND equipment. Not too technical... it tells its story in language anyone can understand. Here is JUST THE INFORMATION YOU NEED to make money on Sound this Spring and Summer. Profusely illustrated showing Lafayette Amplifiers, complete P.A. Systems and accessories. LIST PRICES throughout!

Get two or three copies. Leave them with prospects. Let them sell themselves the P.A. Equipment they need. Explains the fundamentals of sound; how to select input devices, amplifiers, etc., how to use D.B. units... in fact everything you or your prospects needs to know about Public Address.

The price per copy is 25c... which is only part of the cost of publishing. Get a few copies! Keep one handy for reference and the others in the hands of prospects. They'll make money for you!

## Novel Audio Amplifier

Here is positively the finest portable P.A. System you have ever seen. It has everything. POWER, VERSATILITY, COMPACTNESS, QUALITY! 10 watts output, two handy cases, built in mixing panel, famous Lafayette 2A3 amplifier, two special Jensen speakers with 12" cones, Weston button current meter. Amazing in its performance!



Write for our big 4 page descriptive folder today.

WHOLESALE RADIO SERVICE CO.  
100 Sixth Ave., Dept. C-44  
New York, N. Y.

Send me Free Supplement to catalog No. 55.  
 I enclose... for... copies of SOUND to  
 Send me further details on the Novel Audio Amplifier.

NAME .....

ADDRESS .....

CITY ..... STATE .....

**WHOLESALE RADIO SERVICE CO.**  
100 Sixth Avenue, New York, N.Y.  
New Branch  
219 Central Avenue, Newark, N.J.

...tive positions, this aiming operation would be impossible unless the mechanics of the sighting and laying devices eliminated their relative movements. When the radio controlled steering gear is operated directly from the aeroplane, the complicated arrangement of signalling to the controlled ship is done away with, and the range of action of the controlled ship is considerably increased.

The ultimate aim of British naval scientists is now centered in the control of an entire fleet of warships by a single small and fast ship. The experiments to achieve this purpose are carried out with television devices. There is no doubt that in the near future some important announcements will be given regarding these experiments. It then will be possible to send out a fleet of unmanned fighting machines, either a fleet of warships or a fleet of aeroplanes in a surprise attack on the enemy, at whatever distance they may be.

## DIRECT-COUPLED P.A. SYSTEM

(Continued from page 603)

rectly at the panel. For example, tone and volume can be varied, mike and phono, pickup can be changed, etc.

The case which houses the two speakers serves the purpose of providing bases for the speakers and also serves as a very practical compact carrying case. Special 12 in. cone dynamic speakers are used. These are provided with accurate matching transformers, assuring best performance regardless of the distance from the amplifier. Each speaker is provided with a 50 ft. cable and plug. A special snap-on cover provides adequate protection against damage for each speaker cone during transportation.

If desired an additional pair of speakers may be added to the system and may be obtained in a case to match the others. These speakers are equipped with their own field supply since the amplifier will supply field current for only two speakers.

The amplifier, which is the "heart" of the P.A. system, is the result of a number of years of intensive research. It employs an improved circuit consisting of a 57 tube directly coupled to a pair of 2A3's in push-pull arrangement. The exceptionally high gain of 80 db. eliminates the need for a pre-amplifier stage, for average microphone usage. The high-frequency response of this amplifier is very good, due to the use of a unique method of neutralization. An 83 rectifier provides ample plate current with excellent regulation.

Although the amplifier is rated at 10 W., it will maintain good tone quality at the peak output of 12 W. Rugged, oversize parts are used throughout to provide high safety factors, but nevertheless the entire amplifier unit measures only 12 x 7 x 7 1/2 ins. high. Figure 1 shows the schematic diagram of the amplifier.

Details of the mixing panel can be seen in Fig. A. It will be noted that there are three controls on this panel, two of which are located near the top. The tone control provides a means for compensating for the variation in the voice of the announcer. Thus, if he has a shrill voice, it may be toned down and made deeper or if he has a particularly deep voice, it may be raised to a higher pitch. The tone control may also be used to reduce needle scratch in phonograph reproduction or static in radio reproduction.

The gain control at the right regulates the volume obtainable from the amplifier when used on microphone, phonograph or radio. The design is such that tone quality is not changed regardless of the position of the gain control.

The microphone button-current control regulates the amount of current flowing through the microphone buttons. The meter at the top of the panel is equipped with a plug and cord that may be plugged into either of the two jacks mounted on each side of the current control. This automatically breaks the circuit of each button, permitting a reading of the current flowing through either button. Of the three switches provided, one is for the A.C. supply. A pilot light directly above this indicates whether the current is "on" or "off." A second switch is for the microphone button current. This also is pro-

vided with a pilot light. The center switch is a change-over switch to permit the operator to change from microphone pickup to phono, pickup or vice-versa, quickly and easily.

At the right of the panel, a group of three terminals are provided for connecting the two-button microphone. Directly underneath, connections are provided for a high-impedance pickup or a radio tuner output. The radio tuner may be connected directly, without using an A.F. transformer. The two 4 prong sockets at the left are for the speaker connections. The large holes are for the 4,000 ohm fields and the smaller are for two 250 ohm lines in series.

The output impedance of the amplifier is 500 ohms. If desired they may be used as far away as 1000 ft. without frequency discrimination or loss of volume. This is possible because of the low impedance speaker matching used in this particular system.

## ALL-WAVE 3 TUBE SET

(Continued from page 603)

the tubes should light up with a dull red glow when the switch is turned to the "on" position. Now connect the headphones in place, plug in one of the coils, connect the negative side of the "B" battery and remove all the tubes but the type 233 from their sockets. Flip the positive "B" wire quickly across its post—nothing in particular should happen except a loud click in the headphones. If this is the case, plug in the other two tubes, attach antenna and ground and you are ready for the first test.

The first adjustment that it may be necessary to make will be in regards to feed-back, or regeneration. This makes itself known by a rushing sound in the phones and a whistle whenever a station carrier is passed in turning the tuning condenser. It should be possible to cause this whistle to appear or disappear by turning the potentiometer arm one way or the other with any coil in the socket. If it is impossible to make it disappear then increase the value of the fixed resistor, R6; any value up to several meg. may be necessary here, depending on the tube. If it is impossible to obtain regeneration with any coil the first thing to do is to reverse the connections to the tickler coil, L3; if this doesn't work it may be necessary to decrease R6, although this is hardly likely, the fault probably being in a poor tube.

If, after patiently trying, it is impossible to get satisfactory control on all coils with the potentiometer alone then it will be necessary to add or subtract turns from the tickler winding of the offending coil until it is possible to control it smoothly.

One more value is of a variable nature and determined only by experiment and that is the antenna coupling condenser, C1. It is dependent on the antenna you are using and may be larger or smaller than given, and may not even be necessary at all in some cases. Experience in tuning in all bands and a large number of stations will enable you to set this at its best value.

The 4 mf. condenser marked "optional" in the circuit diagram is helpful in obtaining smooth operation in all cases but is absolutely necessary if the batteries used are old, otherwise the circuit will oscillate violently at audio frequencies.

Tuning for short waves requires patience and experience to produce outstanding results. The main factor is to tune very slowly across the band meanwhile keeping the oscillation control just inside the point of regeneration; you will soon learn to recognize the hiss that indicates this condition—when you hear the whistle that indicates the presence of a carrier you have a nibble and its up to you to fish until you bring it in. And when you do pull in a real "DX" station note carefully the time and the program and send for a verification card, giving this information and not forgetting to enclose return postage. Then when you tell your friends about it you will have the proof at hand to squelch any accusation of stretching the truth.

### Theory

For those of you who are interested, a short statement of the reasons for the particular design presented is given. The main



consideration was simplicity, both of construction and operation, hence an untuned input stage was chosen to eliminate another tuning control and the necessity of changing two coils each time a shift was made from one band to another.

Now there is nothing particularly new in an untuned R.F. stage in a short-wave set, it has been done before but due to the lack of a choke which was really efficient over the wide band of frequencies involved it has never been very successful. However, with the choke specified, shown on the wiring diagram as, L1, and which is, in reality, as indicated in Fig. 1, three small chokes wound on the same form and each covering its particular band of frequencies effectively, this objection has been overcome.

Another point is that more than one stage of tuned R.F., especially at the higher frequencies, is rather hard to manage even for an experienced constructor, and hence out of the question for the beginner.

Grid detection was used for two reasons: It is somewhat more sensitive than plate detection and the grid leak made the use of another choke, bad practice for a number of reasons, unnecessary. The A.F. stage was added to get further gain and allow of the use of a loudspeaker on local reception.

Grid bias for the first stage and the power stage is secured from the drop across the two resistors, R7-R8, in the negative "B" line. A type 34 tube was used in the first stage, even though no use is made of its variable mu feature for volume control purposes, because such a tube is less liable to the effect known as "cross modulation" or the riding through of a strong signal on the back, as it were, of a weaker one. Due to the absence of tuning in the input stage this effect is particularly liable to be present.

The necessary parts to construct the set are specified below. Where particular trade names are given it is suggested that they be used, as the units have characteristics making them specially desirable for the particular use to which they are put.

It is suggested that the coils be bought ready wound but for those who would like to try "rolling their own," the data is given.

Coil	Length		Length		Turns	Wave-length
	L2	Space	L3	L3		
A	1 1/2"	3/4"	1 1/2"	1 1/2"	5	16-30
B	1 1/2"	3/4"	1 1/2"	1 1/2"	10	29-54
C	1 1/2"	3/4"	1 1/2"	1 1/2"	20	54-110
D	1 1/2"	3/4"	1 1/2"	1 1/2"	52	103-252
E	1 1/2"	3/4"	1 1/2"	1 1/2"	140	200-585

All forms are 1 1/4" dia. x 2" long.

**List of Parts**

- One Hammarlund Star tuning condenser, 140 mmf., C3;
- One Hammarlund 5 to 70 mmf. balancing condenser, C1;
- One 100 mmf. mica grid condenser, C2;
- One 500 mmf. mica bypass condenser, C8;
- One double .1-mf. paper bypass condenser, 200 V., C4-C5; must be non-inductive;
- One .1-mf. paper bypass condenser, 200 V., C6; must be non-inductive;
- One .01-mf. paper condenser, 600 V., C7;
- One 4 mf. paper bypass condenser, 200 V. (optional), C9;
- One special, "all-wave" R.F. choke coil, L1;
- One set, five plug-in coils for 140 mmf. tuner, L2-L3;
- One Lynch resistor, .07-meg. 1/2-W., R1;
- Two Lynch resistors, .5-meg., 1/2-W., R4-R6;
- One Lynch resistor, 1 to 5 megs. (preferably latter), 1/2-W., R2;
- One Lynch resistor, .25-meg., 1/2-W., R3;
- One .5-meg. potentiometer with switch attached, R5;
- One Electrad resistor, 350 ohms, 1 W., R7;
- One Electrad resistor, 100 ohms, 1 W., R8;
- One solid 4 prong socket for coils;
- Two spring mounted 4 prong sockets;
- One spring mounted 5 prong socket;
- Seven terminal clips;
- One wood baseboard, 8 1/4 x 9 x 5/8-in.;
- One aluminum panel, 8 1/4 x 6 x 1/16-in.;
- One RCA Radiotron, Sylvania or National Union type 33 tube;
- One RCA Radiotron, Sylvania or National Union type 32 tube;
- One RCA Radiotron, Sylvania or National Union type 34 tube;
- One pair sensitive headphones (Baldwin);
- One roll push-back wire;
- Three 45 V. "B" batteries;
- One 2 V. storage cell;
- One vernier dial.



# TAKE A LOOK AT A REAL TUBE TESTER

--The Greatest Advance Ever Made in Tube Tester Design--

**UTMOST SIMPLICITY:**

1. Only 3 simple operations: (1) select proper filament voltage; (2) set tube selector per chart or panel marking; (3) press a button.
2. Direct English-reading scale on full-sized meter.
3. Only 4 sockets—tube cannot be placed in wrong socket—no adapters required.
4. Extra handling is avoided by making the short and leakage test in the same socket used for the quality test.
5. So simple the customer can operate.

**GREATER ACCURACY:**

1. Line voltage adjustment on meter for accurate tests, 100-125 volts.
2. Quality test indicates "GOOD" and "BAD" tubes, based on accurate calibration.
3. Large neon glow lamp indicates "shorts" and leakages up to 100,000 ohms between ALL tube elements. Indicates any offending element.

**SERVICE RELIABILITY:**

1. Efficient over-sized transformer—circuit constants designed to withstand any short-circuit or over-load hazard without necessity of fuses.
2. Impossible to harm tester by incorrect operation.
3. Unexcelled construction.

**PRACTICAL UTILITY:**

1. Tests ALL elements of ALL radio receiver tubes.
2. Maximum of flexibility for future tubes.
3. All popular tubes verichromed on bakelite panel.
4. Complete listing of all present tubes on chart, with ample space for future tubes.
5. Ruggedly constructed and housed in beautifully finished hardwood carrying case with detachable cover—ideal for both service calls and counter tube testing.

**POINT TO POINT LEAKAGE TEST—Supreme Achievement**

Leakages between ALL tube elements are indicated by means of the new neon glow lamp which is ideally suited for such tests. For example, suppose the user is testing a type 24A tube; the neon lamp glows when the No. 1 button is depressed and again when the No. 2 button is depressed. This would indicate a leakage between the screen and plate elements. The neon lamp is superior to a meter for leakage indications because of the inherent mechanical inertia of meter movements which does not enable meters to respond to leakage currents of extremely intermittent characteristics; whereas, the neon lamp "flashes" such leakages with the speed of light. Tubes have been found with leakages as low as 6,000 ohms between elements and which "pass" the usual short tests of ordinary testers; such tubes, however, are instantly detected by the neon glow of the new Supreme Model 85.

herent mechanical inertia of meter movements which does not enable meters to respond to leakage currents of extremely intermittent characteristics; whereas, the neon lamp "flashes" such leakages with the speed of light. Tubes have been found with leakages as low as 6,000 ohms between elements and which "pass" the usual short tests of ordinary testers; such tubes, however, are instantly detected by the neon glow of the new Supreme Model 85.

Write for Literature and Model 85 "TECHNICAL DATA"

**SUPREME INSTRUMENTS CORP.**  
490 Supreme Bldg. Greenwood, Miss.

# REMARKABLE New CATALOG OF SENSATIONAL RADIO VALUES BY FORDSON

**SENT FREE but WRITE TODAY!**  
**DEAL DIRECT—SAVE UP TO 50%!**  
Most elaborate catalog ever issued on our complete line of radios for every purpose, and in NEW VALUES we offer. Just off the press, already in big demand (includes complete technical information, wiring diagrams, etc.). To get your copy promptly send card or coupon AT ONCE!

## 4-TUBE ALL-WAVE SENSATION!

Only in new catalog will you see this remarkable, powerful little 4-Tube All-Wave, All-DC radio. Nothing like it ever produced! Being all-wave to new low price for quality manufacture. Latest Air-Cell battery sets also shown!

## ANY SET ON 30-DAY FREE TRIAL!

Fordson radios are guaranteed on money-back basis. Enjoy any set in your own home for 30 days—judge Fordson Value for yourself. Know why one owner writes: "You are doing for Radio what Henry Ford did for Auto industry—Not how cheap but how Good! Many models: AC-DC; battery; long and short wave; all-wave supers; 6 and 32 volt; consoles; all-electric auto radio. Sets for home, car, farm, camp, cottage, boat and foreign use. **GUARANTEED 30-DAY TRIAL.** Send for new catalog. Prices will amaze you, from **9.45 up**

**OUR AGENTS MAKE MONEY**—no experience needed. Literature and sample sets FREE. Write! **SEND CARD OR COUPON TODAY**



4-tube AC-DC



5-tube Dual Wave



8-tube All-Wave



6-tube All-Electric Car Radio



6 & 32 Volt All-Electric Adapter

FORDSON RADIO MFG. CO.  
Dept. 4, 4180 Oakman Blvd., Detroit, Mich.  
Send me FREE catalog and agent's offer (this is not an order).  
NAME .....  
ADDRESS .....  
CITY .....

# CLAROSTAT

since 1920 The Profit Line

Replacement Volume and Tone Controls  
Standard Volume and Tone Controls  
with an Ad-A-Switch consisting of  
wire wound (Series "W"), composition  
element (Series "C")

Replacement Line Ballasts  
Automatic Line Voltage Regulators  
Flexible Pig Tail Resistors  
Center Tap Resistors  
"L" Pads, "T" Pads, Series Mixers



Clarostat Ad-A-Switch Controls



Clarostat Line Ballast

Clarostat Ad-A-Switch line comprises the maximum utility with minimum stock investment.

Write for New Replacement Control Guide

Clarostat Mfg. Co., Inc.  
267 N. 6th St., Brooklyn, N. Y.

## TWENTY WAYS TO IMPROVE SETS

(Continued from page 595)

some extent the effects of cabinet resonance that produce "boomy" sounds when any bass note is struck.

To increase the effectiveness of this "resonance muffler" the other interior walls of the reproducer compartment can also be lined with sound absorbing material, or another method described recently in RADIO-CRAFT may be used (January, 1934, page 397). The last two methods can be resorted to in severe cases, when the bass output is quite noticeably distorted.

### Control of Tone

It has been generally admitted that tone control devices do produce some improvement in the tonal quality of the set, under certain conditions. This is particularly true when DX stations are being received, as the background noise can be reduced by cutting out some of the higher frequencies.

For those who desire to add a tone control to sets not so equipped, the circuits of Fig. 2A and B are given. It will be noticed that in both cases the control device consists of a .1-meg. variable resistor in series with a fixed condenser. The value of the condenser determines the sharpness with which the cut off of high frequencies takes place. Usually a condenser of about .02-mf. is correct although different values can be tried to suit individual conditions. Then by varying the value of resistance, the amount of bass depth can be chosen.

Another use for tone control devices will be covered later.

### Improving Selectivity and Gain

Radio receivers made several years ago were troubled to some extent by the fact that the amplification was not equal on different parts of the band. In other words, the amplification at the higher frequencies was less than that at the lower frequency end of the dial, with the result that the low wavelength stations did not come in nearly as loud as those on longer wavelengths.

To overcome this, modern sets usually employ coils of the type shown schematically in Fig. 3. In this type of coil the primary is in the form of a lattice or universal-wound coil placed at right angles to the secondary at the grounded end of the latter. This coil is wound with a large number of turns and in the case of the aerial coil, it is actually tuned to a wavelength that is longer than the highest one to be received. In addition to this change in construction, a single turn of wire is wrapped around the grid end of the secondary and is connected to the plate or aerial end of the primary. The latter turn provides some capacitive coupling to the secondary that further increases the high-frequency gain.

These coils are available from most mail order houses and some radio stores and the experimenter will find that by their use a set can be materially improved. By the addition of such coils and the use of higher gain tubes, as previously described a set can be made to rival the latest type receivers in both selectivity and sensitivity.

To still further improve it, in the important point of appearance, there has just been placed on the market an airplane type dial that can be used to replace the present dial on many sets. If the set you are modernizing uses a full-vision dial of practically any type (not the drum type) it can be replaced by this new type of dial. Two types of these dials are shown in Fig. B.

### Visual Tuning Meter

If your set is a superheterodyne, or if automatic volume control is used, a visual tuning meter of one type or another is really an essential to correct operation. If the signals are not tuned in correctly with either of the above sets, the quality is liable to be very poor.

There are several types of visual tuning meters available that can be added to existing sets, providing there is space on the control panel to mount them. As you probably know, the visual tuning meter is simply a sensitive galvanometer (similar to a milliammeter) which is placed in the plate circuit of,

one or more R.F. tubes. Then, when no signal is tuned in, the meter registers the normal plate current of the tube or tubes. However, when a signal is tuned in, the plate current changes and the greatest change shows when the signal is correctly in tune.

As the movement of the tuning meter is similar in design to a D.C. milliammeter it must be connected correctly in the circuit, or it will read in reverse. See Fig. 4.

### Adding Automatic Volume Control

Many of the sets made before 1932 were not equipped with A.V.C. and as this convenience in radio reception is almost universally included in modern sets some experimenters may desire to add a separate unit to permit A.V.C.

The usual method of using one plate of a duo-diode triode tube for A.V.C. is not very satisfactory for existing sets, as this type of tube is too recent to be included in the sets to be modernized. As a result, some of the older methods are preferable and as they have been explained in past issues of RADIO-CRAFT, we will not repeat them, but simply refer to the correct issues. These references are—RADIO-CRAFT, November, 1930, page 287; December, 1930, page 334; May, 1932, page 667.

While on the subject of A.V.C., it might be well to point out that A.V.C. is not satisfactory in sets that do not use variable mu tubes—they will not work satisfactorily. However, if these tubes are inserted as explained previously in this article, the A.V.C. unit can also be added.

### Phono-Radio Connections

The subject of home phonograph recording and record playing, in conjunction with the amplifier of the radio receiver is one that has attracted many radio experimenters. That good results can be obtained by simple circuit changes has been pointed out many times. Many radio fans hesitate to try the interesting experiments possible with records and recordings, however, because they are frightened off by the changes necessary in the receiver.

The changes are quite simple, though and will not affect the operation of the set in any way. In Fig. 5 are shown the methods required for different types of tubes. At A, B

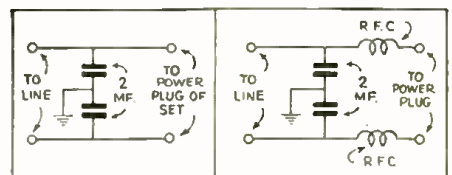

Fig. 7  
Adding a "line-noise eliminator."

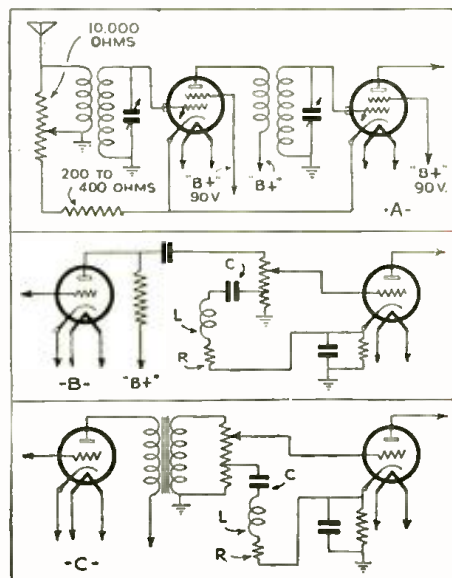

Fig. 8  
Improved volume and tone controls.



and C are shown three methods of using the audio amplifier in conjunction with a phono pickup to amplify recordings. At A is shown the detector circuit of many sets of the vintage of 1926 to 1929. This is the grid leak type of detector. In this type, a resistor and a condenser are connected in parallel and inserted in the cathode lead which is ordinarily connected to chassis or ground. The phonograph pickup is then inserted between the grid of the tube and the chassis. A switch can be included in the set to short-circuit the resistor and condenser when the radio is to be used. At B is the more common plate detection circuit, and here again the pickup is connected between the grid and chassis. However, in this case, the grid circuit must be opened so that the pickup will not be shorted. Another switch is included to short-circuit part of the bias resistor so that the correct bias can be obtained for utilizing the detector as a straight A.F. amplifier. The value of bias resistance required in circuit A and the tap in the bias A tube table can be used to determine the value of this resistor.

At Fig. C is shown a more modern circuit using a diode-triode tube. The pickup is connected directly to the grid of the triode section—no circuit changes or switches are needed.

At D is shown the method ordinarily used to connect the output of an amplifier to a record cutting head. In some cases it is possible to use a phono pickup as a cutting head, by placing a weight on the arm supporting the pickup.

Whether a pickup unit or a special cutting head is employed, a coupling transformer is required to couple the power tube to the cutting device. The ratio of this transformer depends on the type of tube and the impedance of the cutting head. Most manufacturers of the latter units can also supply coupling transformers.

#### Noise Reduction in Aerials

The improvements in sensitivity and quality mentioned earlier in this article may introduce another difficulty that is being encountered in all modern high-gain receivers; that is, excessive noise pick up in the aerial. Naturally the more sensitive the set is made, the more annoying will be the pick up of local disturbances. It has been proven that in most shielded receivers, the pick up of noise is mostly in the aerial and lead-in. In many cases, the aerial can be so placed that it does not pick up much interference, but the effects are ruined by the fact that the lead-in runs close to the electric light, telephone and other wires in the house.

By the use of either a shielded lead-in or a transposition lead-in arrangement, as shown in Fig. 6A and B, this pick up can be avoided. The device at A consists of a coupling arrangement in which the impedance of the circuit carrying the signals to the receiver is reduced, so that the loss in the transfer is kept at a minimum.

The device at B consists of a T type aerial, each side of which is brought down to the set individually, the two lead-in wires being changed in position every few feet as shown. This transposition of the lead-in wires prevents any pick up in a manner similar to that used in twisted wires (such as those for A.C. filaments and the A.C. power leads).

The other source of noise pick up common in radio receivers is through the power supply lines. This can be reduced by one of the methods shown in Fig. 7. This consists of condensers, connected across the power lines feeding to the set or at the interfering electrical device, which effectively bypass the interference to ground. The condensers should be not less than 2 mf. and in the case of B the coils can be wound with about 100 turns of bell wire on a form 1 in. in diameter.

#### Remote Control

Another field that is receiving considerable interest in the past few months is the remote operation of radio receivers, several manufacturers having introduced sets of this type.

There are several remote control devices available that can be added to existing sets, such as the one shown in Fig. C, to effect

## For a UNIVERSAL SINGLE INSTRUMENT TEST SET use the NX Universal Rectox



**T**HIS type NX Westinghouse panel-mounting instrument was specially developed for the radio service man who wishes to build his own test set.

The self-contained instrument covers the following ranges:

Milliamperes, d-c.	0-1
Milliamperes, a-c.	0-1
Millivolts, d-c.	0-100
Volts, a-c.	0-5

For additional ranges, we can supply resistances for voltage measurements, combination shunts for current measurements, and resistors for resistance measurements.

These accessories give the following ranges:

Volts, d-c.	0-1-5-10-50-100-200-500-1,000
Volts, a-c.	0-10-50-100-200-500-1,000
Milliamperes, d-c.	0-5-10-50-100-500
Milliamperes, a-c.	0-5-10-50-100
Amperes, d-c.	0-1-5-10-50
Ohms	0-1,000-10,000-100,000

With these ranges, practically any measurement of voltage, current or resistance can be made for checking receiving-set operation; for test bench work; for laboratory experiments; or for the adjustment and operation of transmitting sets. The instrument ... with its complete set of accessories mounted on a panel or in a box, with the necessary switches ... makes an ideal test set.

Catalog 43-341 describes the construction features that result in the high quality of the NX Universal Rectox Instrument, lists the instrument and all accessories, and includes connection diagrams. Send the coupon or post card for a copy.



Since 1888, manufacturers of highest quality instruments, which are now available at standard prices. There is no longer any reason for accepting lower standards. Some good territory is still open for dealers.

# Westinghouse

SEND FOR CATALOG

Westinghouse Electric & Mfg. Company  
Dept. 123, Room 2-N, East Pittsburgh, Pa.  
Send free copy of Catalog 43-341 containing complete description and connections of the Universal Rectox Instrument.

Name .....  
Address .....  
City ..... State ..... T 79911  
RC 4-34

Be sure to read the announcement on the inside front cover which gives important information about the new AIR CONDITIONING SERVICE MANUAL now being published.

Never before so much  
adding machine for  
so little money

A "portable" - with big machine features. A genuine Remington that adds, lists, multiplies, yet takes up less table surface than a letterhead. Carry it one-handed, with ease. Only \$80.00 cash - or time payments arranged. Write for a free trial in your office, store or home.

REMINGTON RAND, Dept. 333  
465 Washington St., Buffalo, N. Y.

## "PERFECTED" ALL-WAVE SET

12,500 MILES ON ONLY TWO TUBES!

Simple to build—easy to operate—World-Wide reception range—and extremely inexpensive! We

have sold thousands of these remarkable short-wave kits and novices and "old-timers" alike have marveled at the amazing results obtained.

These kits contain every necessary part to construct the entire receiver. The coils, which tune from 15 to 200 meters, are wound on polished bakelite forms. The attractive crystal finished metal chassis and panel comes with all holes necessary to mount the apparatus and this, together with our complete, detailed, clear instruction sheets greatly simplifies construction.

DRY CELL OR AC MODEL \$4.75  
Two Coils 200 to 625 Meters \$1.25  
Deposit required with all orders.

HARRISON RADIO CO.  
142 LIBERTY ST., Dept. R-4, NEW YORK CITY



# The SHURE TECHNICAL BULLETIN

is valuable in your library.

Devoted to the advancement of microphone technique, this monthly publication of Shure Brothers Company, *Microphone Headquarters*, contains authoritative and useful information on technical phases of broadcast and sound engineering, design data, new applications of microphones.

These back issues are available at 6c per copy:

- No. 1 Condenser vs. Two-Button Microphones
- No. 2 Field Problems in Microphone Placement. Part I—Broadcasting
- No. 3 Field Problems in Microphone Placement. Part 2—Public Address
- No. 4 Mixing Circuit Design Data
- No. 5 The Microphone—An Electric Ear. Noise Measurements—Binaural Transmission
- No. 6 Field Problems in Microphone Placement. Multiple Microphone Systems
- No. 7 Electro-Acoustic Measurements of Microphone Performance
- No. 8 High Quality Sound Reproduction. An Outline of Factors Affecting Fidelity
- No. 9 The Truth About Microphone Response Characteristics

SHURE BROTHERS COMPANY  
215 W. Huron Street, Chicago, Ill.

Send me postpaid the following issues of the SHURE TECHNICAL BULLETIN:

... No. 1 ... No. 2 ... No. 3 ... No. 4  
... No. 5 ... No. 6 ... No. 7 ... No. 8  
... No. 9 (6c per copy)

... Enter my subscription for one year. (Price 50c)

I am enclosing .....c. .... in stamps  
.....cash ..... money order.

Name.....  
Address.....  
City and State.....

## RADIO for 1934

NO SERVICEMAN DEALER OR SET BUILDER CAN AFFORD TO BE WITHOUT THIS BOOK

Send for the most valuable book in Radio. Packed with quality and value. Lists the most complete line of radio replacement parts for any service requirement.



Features latest type set building kits, test instruments, Long and Short Wave Radios, Sound Systems, etc.

Write for this Catalog today!

# FREE

### ALLIED RADIO CORP.,

Dept. D, 433 W. Jackson Blvd.  
Chicago, Illinois.  
Please send me FREE your New 1934 Radio Book.

Name.....  
Address.....  
City..... State.....

## Allied Radio

the same results as these new sets. However, since the details for installing these devices vary so widely, no details are given here. Suffice to say that it is not difficult to install them and the manufacturers supply full details for this purpose.

### Volume Control

The methods of controlling the volume in radio receivers has changed somewhat in recent models. Some time ago, it was common practice to control the volume by shifting the screen-grid voltage. However, with the advent of the variable mu tube, this became inadvisable as it changed the characteristics of the tube and defeated to some extent the advantages gained by the new type of tube. For this reason the use of some method of controlling the grid bias, by adjusting the cathode resistance has become almost universal. In order to further increase the effectiveness of the volume control in sensitive sets, the method shown at A in Fig. 8 is often used. This can be easily inserted in existing sets.

The methods shown in Fig. 8B and C represent a compensated volume control arrangement which eliminates the loss of low notes on low volume levels. In other words, it is a tone control circuit that acts only on very low volume, so that the same high quality can be obtained at any desired signal strength.

The unit is designed for sets using a volume control in the A.F. amplifier. The values of the parts in Fig. 8B are: C, .1-mf.; L, .3-hy, choke; R, 3,000 ohms. In Fig. 8C for transformer coupling, the values are: C, .02-mf.; L, 1.5 hy, choke; R, 15,000 ohms. The values mentioned above are only approximate, as the actual values depend upon other circuits of the set. However, they give actual values worked out for one receiver and will give the experimenter comparative figures to work from.

In conclusion, it might be pointed out that it is not always possible or desirable to incorporate all the above suggestions in a set. For example, there are some experimenters who do not approve of tone control devices or other suggested improvements. These, of course, can be omitted. In preparing this article, an attempt was made to cover many of the recent developments in set design. As mentioned before, though, it is not possible to give so many actual circuits of receivers and therefore only fundamental circuits and average values are given here.

## SHORT-CUTS IN RADIO

(Continued from page 597)

changes it can be made to test any tube in common use.

First thing to do, is to take out the large socket, and put a UX sub-panel socket in its place. A hole is then drilled in the case, at the right of this socket, to pass the grid lead. Then the transformer is taken out and the additional filament winding put on over the coil as it is. Each lead is carefully marked before unsoldering, so no mistake will be made when the transformer is put back, as several of the leads have the same color. The winding consists of 22 turns tapped at the 14th, to give 2½ and 1½ V. This gives us 3 voltages which is enough, because the automotive series can be tested on the 5 volt tap, and the 2 volt series on the 1½ tap, by increasing the voltage (adjusting the Clarostat in the primary circuit) so the needle goes beyond the arrow on the filament meter. (See diagram.) A 5 point tap switch is then mounted on the side, with the shaft insulated from the case. Alternate points are used so no two of the taps will be shorted. This switch is used to give the proper voltage to the sockets.

Then the 199 socket is taken out for it may be left in and used as originally intended, but 99's are just about extinct around here, so the socket and series resistor were removed, and another type of socket put in its place, making one less adapter required, and the hole reamed out enough to pass a regular tube base, and a 6 prong socket put in, and wired up to test 89, 57 and 58 tubes.

All UX triodes are tested in the UX socket

on the panel, and other tubes by use of simple adapters, easily and inexpensively made up. All multi-grid tubes have their adapters wired so total omission is recorded. Examples: a 24 tested in the 27 adapter showed—filament omission—40, plate button up—0 plate button down 3. But tested in its own socket it read—fil.—60, and plate b, up—1—p.b, down—8. And a 47 in the 27 socket read—fil, 40, p.b, up—0, p.b, down—4, but in its own socket it read—fil, 80—p.b, up 4 p.b, down—12.

This tester was changed over about a year ago and has proven most satisfactory. As new tubes came along adapters were made up to fit them. However, the new Alden universal adapter, recently put on the market, will save making up so many adapters (in which case the 6 prong socket on the panel can be changed to some other combination).

## RADIO SET PRINTS NEWSPAPER

(Continued from page 591)

of course, we are speaking of the future when, we premise, there will be several millions of these sets in use. The advertising revenue from such a large circulation will be quite heavy, and the broadcasters will, no doubt, be able to get a sufficient amount to make it worth their while.

As to technical details, let me first state that, whatever I have said here, comes strictly within present-day radio technique. The apparatus which I illustrate is simply an adaptation of that now in use by RCA, and open to public traffic at the present. The original apparatus now used was devised by Capt. R. H. Ranger, formerly research engineer with RCA. The receiver, or picture reproducer, during the past few years, has gone through a number of changes. At one time an ink-pen arrangement was used with a special waxed paper. Later on, a jet of hot air was used, the force of the jet being modulated or varied in accordance with the light and dark parts of the picture, all by means of an electromagnetically operated valve, built into the air jet. The chemically-prepared paper, on which the image was reproduced, was wrapped around a cylinder, driven by a specially synchronized motor rotated in perfect step or synchronization with a similar cylinder containing the original picture at the transmitting station. The hot jet air apparatus has been abandoned in favor of the present ink-vapor jet, which is now being used; since it gives better details than the former hot-air jet. We recently saw pictures, measuring 8½ x 12 ins., being recorded on a 21 meter wavelength transmitted over 2,500 miles (from San Francisco). The same apparatus is used to handle commercial orders for pictures, received from Europe, on short waves day or night; the day wavelength being about 21 meters and that for night 30 meters or more, depending upon atmospheric conditions.

At the transmitting end, the photograph is rotated on a cylinder which is kept in perfect synchronization by special synchronizing means, including a temperature controlled tuning fork and a powerful concentrated pencil of light; the latter scans the photograph, line by line, as the cylinder on which it is mounted rotates in front of a pair of concentrated-filament headlight bulbs and a pair of lenses. The light reflected from the photograph being scanned passes through a small black tube and a diaphragm, into a photoelectric cell connected in a special bridge circuit. Before the photoelectric cell's impulses are sent over the line or by radio waves to the receiver there is imposed on the "image signal" a special accurately-timed interruption signal which has the effect of breaking up the dots constituting the image at the receiver, and serves to produce the well-known halftone effect.

In some picture-facsimile systems the width of the line is modulated; but in the RCA system the length of the dots is changed in accordance with the highlights and shadows of the image being transmitted, and as previously mentioned, the dots are furthermore split up into fractional dots so as to get a better halftone effect, as has been found to be the case in practice.



# BYRD'S CHOICE!

## Why not Yours?

Chosen for 10 to 570 meter work on the Byrd Antarctic Expedition, **MASTERPIECE II** is, by this very token, the most competent all-wave receiver available to you.

To Admiral Byrd, absolute dependability in the matter of transoceanic reception is a vital necessity. Realizing this fact, from his previous experience in the Antarctic, Admiral Byrd selected Masterpiece II for "all-wave" work only after exhaustive tests had proved it thoroughly capable of daily reception from all parts of the world.

Truly enough, such performance is not of life and death importance to you . . . it is not absolutely necessary that you be able to tune in stations 10,000 miles distant simply for pleasure's sake . . . but there IS a tremendous amount of satisfaction in owning a receiver that WILL give you WHAT you want WHEN you want it. THAT receiver, as conclusively demonstrated by Admiral Byrd's choice, is **MASTERPIECE II**.

**McMurdo Silver, Inc.**  
1735 Belmont Avenue  
Chicago, U. S. A.



Photo of McMurdo Silver and Admiral Richard E. Byrd, U. S. N. taken just before the start of the second Byrd Antarctic Expedition.

## 10 DAY TRIAL

You are entitled to the same quality of radio performance that Admiral Byrd and others insist upon. I guarantee that my Masterpiece II will give you that kind of performance . . . but I let you be the sole judge. Either you get what you want out of my Masterpiece II or you get your money back instantly, without question or argument. It's just as simple as that. My new book tells all about this offer and gives full technical details of Masterpiece II. The coupon will bring it.



McMurdo Silver, Inc., 1735 Belmont Ave.  
Chicago, U. S. A.

Send me full technical information on Masterpiece II.

Name.....

Street.....

Town.....State.....

## LATEST IN RADIO NEW CAR SET

(Continued from page 586)

Another feature of this set is its "key knob." This knob is located on the lower left-hand side of the remote control unit and operates the volume control and off-on switch; further, the set may be made inoperative, so that unauthorized persons cannot operate it, by pulling the knob outward, when the knob, and a key that forms part of it, may be removed.

The I.F. transformers are peaked at 175 kc. Automatic volume control and first-detector operation are obtained in the diode section of the type 75 tube; its triode section operates as an A.F. amplifier.

In the 6A7 are combined the operations of first-detector and oscillator.

A suppressor kit, including a distributor suppressor and a generator bypass condenser, and all necessary hardware for mounting the set, are included.

The remote control tuning dial is calibrated directly in kc. When aligning the R.F. circuits, the tuning control must first be attached to the tuning condenser shaft with the pointer set at 530 and the tuning condenser plates entirely meshed. To align the circuits, tune in a weak signal near 1,400, and at its correct dial reading, and adjust the first and second trimmers on the variable condenser gang (from front of chassis), for loudest signal. If the signal is not received at its correct dial setting, carefully adjust the rear trimmer on the condenser gang to shift the signal to its correct location, and then re-adjust the first and second trimmers. After re-installing the set in the car, slightly re-adjust the first trimmer.

## THE RADIO MONTH IN REVIEW

(Continued from page 583)

explained. You know how sleepy you get when you ride for a long time in a car or a train. The continuous repetition of (monotonous) sounds such as the click of a train over the tracks or the drone of the car motor is what does the trick.

The Hypnotone, as the new device is called, is a device that acts in a manner very much like the train or auto—it is an audio frequency oscillator; a device known to all radio men—that sends out a tone of just the right volume and pitch to put you or the baby to sleep in the shortest possible time.

It is necessary to provide individual control of both the volume and pitch, since not everyone hears sound the same way.



Above, chassis view of the new radio set. Right, schematic circuit of the receiver. Late tube types, including an 84, are used in an efficient circuit.

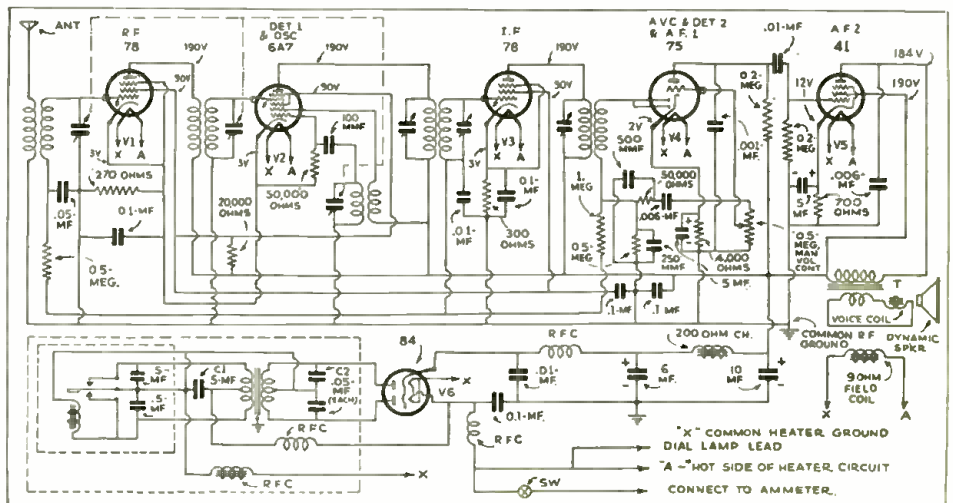

# THE IMPROVED SHALLCROSS

No. 686 A.C.

## UTILITY METER

with Line Voltage Adjustor



**CAPACITY**  
0.005 Mfd. to 10 Mfd.

**INDUCTANCE**  
.5 Henrys to 10,000 Henrys

**RESISTANCE**  
25 ohms to 5 megohms.  
A.C. voltage ranges  
0-10-125-500-1000

To maintain calibration an adjustment is provided to correct for variations from 105 to 125 volts.

This instrument is easy to build. The important parts required are a 1 milliamper A.C. (Rectifier type) meter and the SHALLCROSS No. 686 A.C. Utility Meter Kit and meter scale.

Send 3c. in stamps for Bulletin No. 686-P describing this useful test instrument.

**SHALLCROSS MFG. COMPANY**

Electrical Measuring Instruments  
and Accurate Resistors

700 MAC DADD BOULEVARD  
COLLINGDALE, PA.

# WEBSTER CHICAGO

**NEW Three-Stage  
10-Watt Microphone  
and Phonograph  
Amplifier**



**Provides Microphone Current  
Has Dual Control  
Is Completely Enclosed  
SEND FOR BULLETIN!**

**The Webster Company**

3830 WEST LAKE ST., CHICAGO, ILL.

THE WEBSTER CO. Use This Coupon  
3830 W. Lake St., Chicago, Ill.

Gentlemen:—I am a [ ] Dealer, [ ] Serviceman,  
[ ] P.A. Specialist and want all information on your  
353 Amplifiers.

Name .....

Address .....

City ..... State .....

## INFORMATION BUREAU

(Continued from page 610)

### NEW RADIO DISTRICTS

(255) Mr. Abraham Levin, Joplin, Mo.

(Q.) The writer has been advised that the listing of radio districts as published in the Information Bureau of the May, 1930 issue of RADIO-CRAFT has been superseded by a new classification. Please furnish whatever information you may have available in this connection.

(A.) Your informant is correct. The reorganized radio districts are discussed as follows in a recent release by the Federal Radio Commission:

The field service of the Federal Radio Commission has been reorganized into twenty districts, each in charge of an officer whose title is "Inspector in Charge."

The reorganization was accomplished by making the nine large radio districts, established under the Radio Division of the Department of Commerce, since transferred to the Commission, into smaller districts.

The list of districts, showing the territory embraced and the location of the headquarters office is as follows:

**Radio District No. 1:** Headquarters, Customhouse, Boston, Mass. *Territory:* Maine, New Hampshire, Vermont, Massachusetts, Connecticut and Rhode Island.

**Radio District No. 2:** Headquarters, Federal Bldg., 641 Washington St., New York, N. Y. *Territory:* City of Greater New York and the Counties of Suffolk, Nassau, Westchester, Rockland, Putnam, Orange, Dutchess, Ulster, Sullivan, Delaware, Greene, Columbia, Albany and Rensselaer of the State of New York, and the Counties of Bergen, Hudson, Passaic, Sussex, Warren, Morris, Essex, Union, Somerset, Middlesex, Monmouth, Mercer, Hunterdon of the State of New Jersey.

**Radio District No. 3:** Headquarters, Gimbel Building, 32 Ninth St., Philadelphia, Pa. *Territory:* City of Philadelphia and the Counties of Bucks, Montgomery, Philadelphia, Delaware, Chester, Lancaster, York, Adams, Cumberland, Perry, Dauphin, Lebanon, Berks, Schuylkill, Lehigh, Northampton, Carbon and Monroe of the State of Pennsylvania, and the Counties of Ocean, Burlington, Atlantic, Cape May, Cumberland, Salem, Gloucester and Camden of the State of New Jersey; State of Delaware.

**Radio District No. 4:** Headquarters, Fort McHenry, Baltimore, Maryland. *Territory:* State of Maryland, the District of Columbia, and the Counties of Arlington, Loudoun, Fairfax, Prince William, Fauquier, Rappahannock, Page, Warren, Shenandoah, Frederick and Clark, of the State of Virginia.

**Radio District No. 5:** Headquarters, Customhouse, Norfolk, Virginia. *Territory:* State of Virginia, except the Counties of Arlington, Loudoun, Fairfax, Prince William, Fauquier, Rappahannock, Page, Warren, Shenandoah, Frederick and Clark, and the State of North Carolina, except the Counties of Ashe, Watauga, Caldwell, Avery, Burke, McDowell, Yancey, Mitchell, Madison, Buncombe, Haywood, Swain, Graham, Cherokee, Clay, Macon, Jackson, Transylvania, Henderson, Polk, Rutherford and Cleveland.

**Radio District No. 6:** Headquarters, 528 Postoffice Building, Atlanta, Georgia. *Territory:* States of Alabama, Georgia, South Carolina, Tennessee, and the Counties of Ashe, Watauga, Caldwell, Avery, Burke, McDowell, Yancey, Mitchell, Madison, Buncombe, Haywood, Swain, Graham, Cherokee, Clay, Macon, Jackson, Transylvania, Henderson, Polk, Rutherford, and Cleveland of the State of North Carolina.

**Radio District No. 7:** Headquarters, 1424 Bade County Building, Miami, Florida. *Territory:* The State of Florida.

**Radio District No. 8:** Headquarters, Customhouse, New Orleans, La. *Territory:* The States of Louisiana, Mississippi and Arkansas.

**Radio District No. 9:** Headquarters, Chamber of Commerce Building, Galveston, Texas. *Territory:* Counties of Jefferson, Chambers, Harris, Galveston, Fort Bend, Brazoria, Wharton, Matagorda, Jackson, Victoria, Calhoun, Goliad, Refugio, Aransas, San Patricio, Mueces, Jim Wells, Kleberg, Brooks, Kenedy, Willacy, Hidalgo, and Cameron of the State of Texas.

**Radio District No. 10:** Headquarters, 464 Federal Building, Dallas, Texas. *Territory:*

State of Texas, except the Counties of Jefferson, Chambers, Harris, Galveston, Fort Bend, Brazoria, Wharton, Matagorda, Jackson, Victoria, Calhoun, Goliad, Refugio, Aransas, San Patricio, Mueces, Jim Wells, Kleberg, Brooks, Kenedy, Willacy, Hidalgo and Cameron, and the States of Oklahoma and New Mexico.

**Radio District No. 11:** Headquarters, 1105 Rives-Strong Building, Los Angeles, Cal. *Territory:* Counties of Monterey, Kings, Tulare, San Luis, Obispo, Kern, Santa Barbara, Ventura, Los Angeles, Orange, San Diego, Imperial, Riverside, and San Bernardino of the State of California; the County of Clarke of the State of Nevada, and the State of Arizona.

**Radio District No. 12:** Headquarters, Customhouse, San Francisco, Cal. *Territory:* State of California, except the Counties of Monterey, Kings, Tulare, San Luis, Obispo, Kern, Santa Barbara, Ventura, Los Angeles, Orange, San Diego, Imperial, Riverside and San Bernardino, and the State of Nevada, except the County of Clark.

**Radio District No. 13:** Headquarters, 227 Postoffice Building, Portland, Oregon. *Territory:* State of Oregon and the State of Idaho, except the Counties of Boundary, Bonner, Kootenai, Shoshone, Benewah, Latah, Clearwater, Nez Perce, Lewis and Idaho.

**Radio District No. 14:** Headquarters, 1012 Exchange Building, Seattle, Wash. *Territory:* State of Washington, the Counties of Boundary, Bonner, Kootenai, Shoshone, Benewah, Latah, Clearwater, Nez Perce, Lewis and Idaho of the State of Idaho; and the counties of Lincoln, Flathead, Glacier, Toole, Pondera, Teton, Lake, Sanders, Mineral, Missoula, Powell, Lewis and Clarke, Cascade, Meagher,

## PHONO. ATTACHMENT

(Continued from page 599)

which is permitted to remain on the ground post of the radio set).

Finally, connect a phonograph pickup (or a microphone transformer, if a microphone is to be used) to the attachment terminals marked PICKUP; start the motor of the phonograph with which the pickup is to be used; and then tune the broadcast set until the phonograph program is heard.

If there is available only a phonograph not equipped with a phonograph pickup, this unit must be provided. By selecting a slightly larger carrying case a phonograph pickup could be carried along with the "attachment," and used as necessary.

### Description of Circuit

The reader will not be bored with a lengthy description of why the circuit works. Instead, only a short, general description will be given.

Although the ways in which circuit oscillation may be obtained are legion, the circuit utilized in our R.F. phonograph attachment is one of the most simple and, for our purpose, efficient. In this instrument the plate of the oscillator-mixer pentode, tube V1, is connected to one end of an R.F. circuit comprising variable condenser C1, and center-tapped secondary S, of coil L1; the screen-grid of V1 is connected to the other end of this circuit (which is resonant in the broadcast band). The center-tap on L1 is connected to the maximum available voltage supply. Upon grounding the control-grid of V1, as shown (only for the purpose of this discussion) dotted, at X, circuit oscillation is obtained; the R.F. output may be taken off by means of a pick-up coil (primary P, of L1), and fed to the antenna and ground connections of any radio set, producing a whistle when the set is tuned to a broadcast station within the operating range of the attachment.

### A "Home" Broadcast Station

However, unless the broadcast set is tuned to a broadcast station, neither the whistle or anything else can be heard. It now remains to merely "modulate" this R.F. output, in some manner, at audio frequency, and our R.F. phonograph attachment will be complete and functioning as a miniature home broadcast station.





# GREATEST OPPORTUNITY



Exact  
duplicates  
ELECTRICALLY

## Ever Offered Service Engineers! KIT OF SIX (6) TRANSFORMERS

Enables you to immediately renew original performance in case of trouble in the power transformer (the heart of the radio) in any of over 90% of all models of radios—"orphaned" or current models.

Universally  
adaptable  
PHYSICALLY

### Universal Input Audio

Can efficiently feed any straight or push-pull audio stage on either A.C. or D.C. sets.

### "Multi-Tap" Output

The Universal primary and the tapped secondary, from 2 to 20 ohms in 2 ohm steps, make it possible to load practically any straight or push-pull output stage to any dynamic speaker.

### "Multi-Tap" Power Transformer

(Patent Applied For)

The wide range of adaptability of only four models "Multi-Tap" Universal Power Transformers is made possible thru various taps in these units which may be used singly or in combinations. The required current values can be delivered to each of the several leads in the set with any combination of tubes, as accurately as the original power units.

**IMPORTANT!** These units are fully shielded, designed for meeting the specification of radios having Underwriters Lab. approval. This is very essential as many states now require such approval to protect the set owners' fire insurance policies.

Furnished in dull satin black finish, unless otherwise ordered.

*Easily Installed!*  
FULL DIRECTIONS WITH EACH UNIT

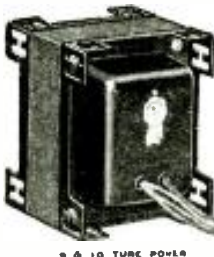
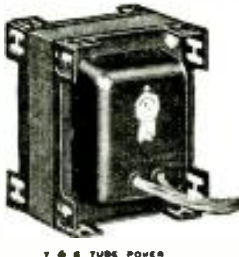

**FULL DIRECTIONS WITH EACH UNIT**  
Above complete set of units are packed individually and in a carton as a standard package for service engineers' initial stock. Additional stock of any unit may be ordered in any quantity.

### Wholesale Distributors! Safest Leader

The "Multi-Taps" are your SAFEST LEADER for winning the replacement trade in the territory you cover.

### A Short Shelf

A SHORT SHELF of "Multi-Taps" enables you to promptly meet every need for power supply replacement units—all staple items, no slow moving or dead stock at any time.

*Free for the Asking!*

Multi-Tap Bulletin No. 3-D, showing electrical characteristics, shipping weight, mounting centers, overall dimensions and list price of each model unit. Also complete listing of 1898 models of radios, and showing which one of the Multi-Taps can be used to immediately restore original performance in cases of transformer trouble.

### MAIL THIS COUPON NOW!

GENERAL TRANSFORMER CORPORATION  
504 South Throop Street,  
Chicago, Ill.

Please send free Bulletin No. 3-D of "Multi-Tap" Universals and list of Radios on which they can be used for replacements.

Name .....  
Address .....  
City ..... State .....

Audio modulation is conveniently accomplished by breaking the control-grid lead of the 43 and inserting a phonograph pickup into the circuit, at connections J1 and J2. The plate and screen-grid currents must pass through resistor R2 and in so doing establish across its terminals a voltage which becomes the "C" bias for the tube. Condenser C2 bypasses the R.F. and A.F. around the grid bias resistor unit R2, thus eliminating its tendency to reduce the A. F. modulated R.F. output of the tube; C3 acts as both a power supply filter condenser, and power supply R.F. bypass; C4 eliminates hum when the attachment is operated on A.C. power lines. We now have a miniature radio transmitter functioning full-boost—it only remains to utilize the signal.

A convenient manner of utilizing the "signal" is to run leads from the primary winding P<sub>1</sub>, located at the center of the secondary of L1, to the antenna and ground posts of any radio set. As most broadcast receivers are more sensitive at the lower end of the wavelength range, this attachment was designed to be operated within approximately the first one-third section of the tuning range. Just tune the broadcast set to a "dead" point on the scale, within this range, at which a broadcast station cannot be heard, and then adjust the setting of C1 on the R.F. phonograph attachment until the phonograph program can be heard. Finally, adjust the volume control on the phonograph pickup for optimum volume and maximum tone quality, and the volume control on the radio set for the desired output volume.

A direct ground connection to the chassis must not be made since, in the reversed position of the line plug, the power line would be shorted, on D.C. power circuits.

#### The Power Supply

To secure operation on A.C. power lines a rectifier is required to furnish the necessary D.C. for the plate and screen-grid of V1. A type 25Z5 tube, V2, was selected for several reasons. First, it has a 25 V. filament and,

in conjunction with V1, a tube that has a 30 V. filament, accounts for 55 V., which requires the filament limiting resistor R1 to "absorb" only 60 V., thus the power cord leads to the minimum degree. Second, although this tube is of the high-vacuum type, it has a very low internal resistance and therefore will deliver to the 43 much more current than would other type tubes.

A special filter choke, designed for A.C.-D.C. sets and having a resistance of only 100 ohms, is used as "Ch." in order to obtain maximum voltage on D.C. power supplies.

If the chassis of the attachment is grounded accidentally in the reversed position of the line plug, fuses F, inside the line plug, will act as safety devices.

Almost any center-tapped R.F. broadcast coil having a centrally-located primary may be used. The authors' coil was made by winding 100 T., center-tapped, of No. 28 wire on a tube 2½ x 1½ ins. in dia., for the secondary; the primary was made by winding 25 T. of No. 32 wire over a layer of empire cloth at the center of the secondary.

Although numerous refinements are possible for those who wish to build a more elaborate unit, there is no need to put such features in a unit that is intended, as was this one, for portable operation. Under the heading of possible refinements would be included, for example, a switch for automatically disconnecting and connecting the antenna to the broadcast set (in portable use such a switch would introduce long leads, in many instances); a built-in electric phonograph motor and turntable (in portable operation, practically impossible due to power supplies often being of several types—in New York, for instance, where the attachment was designed to be used, both A.C. and D.C. power supplies will be found, and sometimes both in the same dwelling; another objection is the weight of electric phonograph motors); and, mixing and volume controls for selecting either, or both phonograph pickup and microphone—the latter for making introductory remarks re-

garding the phonograph program, or comments of a witty nature—(this idea is not so practical for a portable design, since it would call for more equipment, including the controls and a microphone).

The authors will be glad to assist anyone who encounters any difficulty in building this little A.C.-D.C. R.F. phonograph attachment.

#### List of Parts

- One specially-wound antenna coil (see text), L1;
- One variocoupler, 500 mmf., C1;
- One Tube Deutschmann electrolytic condenser, 20 mf., 35 V., C2;
- One Concourse high-temperature electrolytic condenser, 8 mf. (or two 4 mf. units, to save space), 500 V., C3;
- One Concourse electrolytic condenser, 8 mf., 500 V., C4;
- One General Transformer Corp. special A.C.-D.C. choke, 100 ohms, Ch.;
- One Blan power cord (to drop 60 V.), R1;
- One I.R.C. resistor, 2,500 ohms, 2 W., R2;
- One RCA Radiotron, Sylvania or National Union pentode, type 43, V1;
- One RCA Radiotron, Sylvania or National Union rectifier, type 25Z5, V2;
- Two Na-Aid 6 prong sockets, for V1, V2;
- One Blan power switch, Sw.;
- One fused power plug;
- Two fuses, 1 A., F;
- Four insulated tip jacks, J1 to J4;
- One Blan aluminum panel, 5½ x 8½ x 1/16-in. thick;
- One Blan aluminum base, 4 x 5½ x 1/16-in. thick;
- One Blan aluminum shield can (for coil);
- One pair sub-panel brackets, cut to fit;
- One Radio Trading Co. carrying case, 5½ x 8½ x 5½ ins. deep (inside dimensions);
- One phonograph pickup, high-impedance type, with volume control;
- Miscellaneous supplies (wire, solder, coil-mounting bracket, knob for C1 to fit a short length of ¼-in. rod, the other end of which is tapped to fit in place of the adjusting screw furnished with C1).

# HOW TO BUILD, TEST AND REPAIR RADIO SETS



## Radio Construction Library

Including Television, Short-Wave Receivers and Auto Radios. 3 Volumes, 6x9—1177 pages, 561 illustrations. This practical Library includes: **PRACTICAL RADIO**—The fundamental principles of radio, presented in an understandable manner. Illustrated with working diagrams. **PRACTICAL RADIO CONSTRUCTION AND REPAIR**—Methods of locating trouble and reception faults and making workmanlike repairs. Discusses modern Short-Wave Receivers and installation of automobile radios fully. **RADIO RECEIVING TUBES**—Principles underlying the operation of all vacuum tubes and their use in reception, remote control and precision measurements. Helps you to understand modern type receiving sets—full of construction data and practical kinks for the experimenter—a training course for service men.

10 Days' Free Examination  
Easy Terms

McGraw-Hill

### FREE EXAMINATION COUPON

McGraw-Hill Book Company, Inc.,  
330 W. 42nd St., New York.

Gentlemen:—Send me the new RADIO CONSTRUCTION LIBRARY, all charges prepaid, for 10 days' Free Examination. If satisfactory I will send \$1.50 in 10 days, and \$2.00 a month until \$7.50 has been paid. If not wanted I will return the books.

Name .....  
Home Address .....  
City and State .....  
Position .....  
Name of Company.....RC-4-34

# BETTER AUTO RADIO LYNCH

AUTO ANTENNA SYSTEMS

## Do the Trick

- ✓ cut out noise
- ✓ one type for all cars
- ✓ installed in a jiffy
- ✓ no "ripping" out upholstery
- ✓ simplify new installations
- ✓ guaranteed satisfaction
- ✓ clearer reception

Lynch broadcast and short wave noise-reducing antennas have proved their worth in thousands of homes.

Now, Lynch engineers have applied the same principles to the automobile. Many trial installations have been put through rigid road tests. All the "bugs" have been eliminated.

This year's auto receivers are better than ever. They cannot deliver the best results without this new and greatly improved antenna system.

**Bulletin on Request**  
at all Lynch Jobbers, Dealers and Dept. Stores, or sent direct.

**LYNCH MANUFACTURING CO., Inc.**  
51 VESEY STREET NEW YORK, N. Y.  
Makers of Lynch "Noise Reducing" Antenna Systems and Famous Metallized Resistors.

## INFORMATION BUREAU

(Continued from page 620)

Broadwater, Jefferson, Granite, Ravalli, Reerlodge, Silver Bow, Beaverhead, Madison, Gallatin of the State of Montana, and Territory of Alaska.

**Radio District No. 15:** Headquarters, 538 Customhouse, Denver, Colo. *Territory:* States of Colorado, Utah, Wyoming, and Montana, except the Counties of Lincoln, Flathead, Glacier, Toole, Pondera, Teton, Lake, Sanders, Mineral, Missoula, Powell, Lewis and Clarke, Cascade, Meagher, Broadwater, Jefferson, Granite, Ravalli, Deerlodge, Silver Bow, Beaverhead, Madison and Gallatin.

**Radio District No. 16:** Headquarters, 513 Federal Building, St. Paul, Minn. *Territory:* States of South Dakota, North Dakota, Minnesota, the northern peninsula of Michigan, and the State of Wisconsin, except the Counties of Crawford, Richland, Sauk, Columbia, Dodge, Washington, Ozaukee, Milwaukee, Jefferson, Dane, Iowa, Grant, Lafayette, Green Rock, Walworth, Racine and Kenosha.

**Radio District No. 17:** Headquarters, 231 Federal Building, Kansas City, Missouri. *Territory:* States of Nebraska, Kansas, Missouri and Iowa, except the Counties of Winnebago, Allamakee, Fayette, Clayton, Buchanan, Delaware, Dubuque, Linn, Jones, Jackson, Clinton, Cedar, Johnson, Washington, Muscatine, Scott, Louisa, Des Moines, Henry and Lee.

**Radio District No. 18:** Headquarters, 2022 Engineering Building, Chicago, Ill. *Territory:* States of Indiana, Illinois and the Counties of Winnebago, Allamakee, Fayette, Clayton, Buchanan, Delaware, Dubuque, Linn, Jones, Jackson, Clinton, Cedar, Johnson, Washington, Muscatine, Scott, Louisa, Des Moines, Henry and Lee of the State of Iowa; and the Counties of Crawford, Richland, Sauk, Columbia, Dodge, Washington, Ozaukee, Milwaukee, Waukesha, Jefferson, Dane, Iowa, Grant, Lafayette, Green Rock, Walworth, Racine and Kenosha of the State of Wisconsin.

**Radio District No. 19:** Headquarters, 2909 David Stott Building, Detroit, Mich. *Territory:* State of Michigan, except the northern peninsula and the States of Ohio, Kentucky and West Virginia.

**Radio District No. 20:** Headquarters, 514 Federal Building, Buffalo, N. Y. *Territory:* State of New York, except the City of Greater New York and the Counties of Suffolk, Nassau, Westchester, Rockland, Putnam, Orange, Dutchess, Ulster, Sullivan, Delaware, Greene, Columbia, Albany, and Rensselaer; the State of Pennsylvania, except the City of Philadelphia, and the Counties of Bucks, Montgomery, Philadelphia, Chester, Delaware, Lancaster, York, Adams, Cumberland, Perry, Dauphin, Lebanon, Berks, Schuylkill, Lehigh, Northampton, Carbon and Monroe.

filament windings became shorted to one another, thereby depriving the 45's of their biasing voltage. Due, of course, to the normally grounded center-tap of the former. Since replacement of the power transformer was out of the question, the following remedy was tried. The detector filament winding center-tap connection was transposed, from its direct ground, to the center-tap of the 45 filament winding, thus restoring the bias voltage to the 45's without increasing the hum level. The radio now resumed normal operation much to the financial satisfaction of the customer.

JOHN LEBEL,  
Spillville, Iowa.

### CROSLLEY 42-S

A CROSLLEY 42-S came into shop marked "Poor tone, repair speaker." At volume equal to a whisper the set sounded O.K., but when loud enough to reproduce low notes distinctly distortion was present. The speaker was inspected for cone rattle, contact between core and voice coil, then tried on another set, and found O.K. I figured the trouble to be in the A.F. amplifier. After replacing the 3-meg. 1st A.F. grid resistor (which didn't help the tone any) the voltage on the A.F. tube was normal. The voltage chart of set showed normal detector voltage 11 to 17 on grid, and 70 to 85 on plate (due to resistance 1st audio). An analyzer test showed 4 V. bias. Ah! a bias resistor "out." No, it tested between 50,000 and 55,000 ohms (55,000 normal), which was not making all the difference. I checked through the resistor bank, and all were within reasonable limits (all are carbon resistors). I tried substituting some resistors that I knew were accurate. I finally obtained proper bias with a 20,000 ohm resistor, which should have made the voltage way too low for good detection in that particular set. By chance as I was "prettying up" the underside, shortening resistor pigtails and touching up solder joints, double-checking for "cold" ones, the lead to the detector bias bypass broke, and the voltage went haywire again. By this time I was ready to throw a baby sledge at that set, but when I checked the dual 5-mf. unit bypassing both detector bias and 1st A.F. bias, I found a leakage *between sections* that was causing all the grief. Replacing the dual bypass condenser (Fig. 4) and the original detector bias resistor restored the tone quality. Two weeks later the screen-grid voltage bypass "went west" but the customer finally realized, after a half-hour discussion, that it was in no way caused by the previous trouble.

### G.E. J-100 AND J-125 RECEIVERS

ON SEVERAL new G.E. J-100 series and J-125 sets, I was driven frantic by a flood of trouble calls with cathode shorts in 56's and 58's causing bad hum on all stations similar to station hum, and only noticeable when a station was tuned in. I found out that the section of town where calls were originating has very high line voltage (up to 125) in afternoon and early evening, which caused something to "glve" too much inside the tubes. The power transformers in these sets are wound to 112 V. primary, and there was 2.7 V. on the heaters. I purchased several line voltage regulators and installed them on the offending sets, and their owners are not riding my neck as often as they used to.

C. J. HUTCHESON, JR.,  
1027 Blackford Ave.,  
Evansville, Ind.

## OPERATING NOTES

(Continued from page 607)

and to the flat black wire-wound bias and bleeder resistor. This resistor has, in some cases, been found to vary from 6,000 ohms (the correct value) to as low as 2,000 ohms with a consequent variation of plate voltages on the I.F., R.F., 1st-Det., and Osc. tubes. The usual voltage on these tubes is about 90 V. Replacing the defective unit with one of correct value brings gratifying results.

### EDISON R-4, R-5

AN UNUSUAL problem was encountered in servicing an Edison R-4. The complaint of a bad hum and distortion immediately led me to condemn the biasing resistor in the grid circuit of the push-pull A.F. stage. However, a more thorough check-up proved that the trouble was in the power transformer. By referring to the schematic diagram, Fig. 3, one finds that this model has three 2.5 V. windings (filament) namely, R.F. and 1st-A.F.; Det.; and the P.P. A.F. filament supply. The center-tap of the detector filament winding is normally grounded while the adjoining 45 A.F. filament winding is in turn grounded through a series of resistors. In this particular case, these two

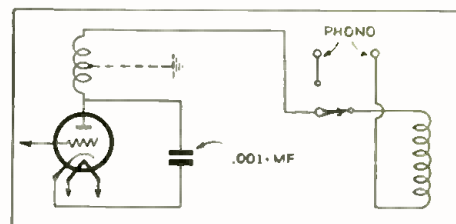
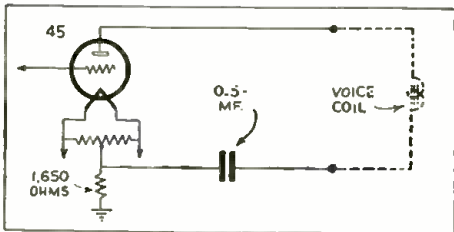

Fig. 5  
Grounded R. F. choke in Edison 7-R set.





**Fig. 6**  
A shorted 0.5-mf. condenser in Crosley 53 (or 54) causes trouble.

### EDISON MODEL 7-R

RECENTLY serviced an Edison 7-R receiver that was not functioning properly. The complaint was that signals would come in faintly and then burst through strong and clear. The chassis was checked and everything was found to be O.K., except the detector plate voltage which was nil. It was found that by tapping the R.F. choke the signals would come in with usual strength. This unit is encased (shielded) and grounded in this model. When this unit was replaced with a new one, reception became normal again. The R.F. choke was grounded, thus short-circuiting the plate supply of the detector to the ground. See Fig. 5.

### CROSLY MODEL 53 (or 54)

**A** GAIN, a Crosley 53 was serviced. This chassis was checked and the grid biasing resistor (1,650 ohms) of the 45 was found to be smoking. The 45 circuit was checked, and the .5-mf. condenser inserted between the voice coil of the speaker and a terminal of the grid biasing resistor was found to be defective. It was replaced with a new one and the set began to function again. See Fig. 6.

JAMES L. HOBBS,  
1345 Eddy Street,  
Providence, R. I.

### CROSLY 40S—41S—42S—82S

**W**HEN SERVICING these machines, it is often necessary to move the chassis to the shop and as the speaker is fastened in the cabinet with screws it is desirable to avoid taking it out. To test a machine of this type under operating conditions, the method outlined below is the best that I have found. This method is to use a dummy field coil, output transformer and a magnetic speaker. Any good filter choke will do in place of the field coil. Any convenient output transformer, primary having fair matching characteristics (the secondary is not used) may be used in the output circuit. This testing assembly is wired as shown in Fig. 7 and is mounted in a small box with a jack for the speaker and two sets of leads; one set terminates in a tube base, the other has phone tips soldered to the ends of the wires.

The latter set of leads are used on the early models having the conventional Crosley speaker connections; that is, pin jacks marked BROWN, N and P. The circuit is as follows: the choke is connected across the brown pin jacks, while the ends of the output transformer are connected to the N and P pin jacks. A lead connects one side of the choke to the center-tap of the trans-

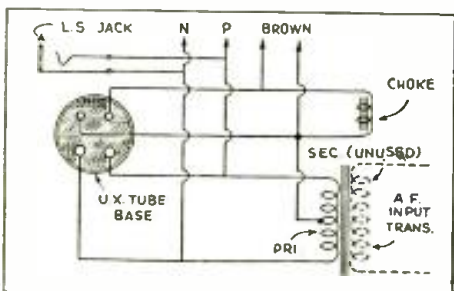

**Fig. 7**  
An inexpensive and convenient "gadget" for testing reproducers without removing them from the chassis.

former. The speaker is connected from the center-tap to either side of the primary winding.

The later type sets use a 4-prong UX-plug speaker connector. The choke is connected across the grid and plate prongs of an old tube base, as shown in Fig. 7, while the transformer is connected across the filament prongs. The center-tap in this instance is connected to the grid-prong lead where it joins the choke. The speaker is connected as described in the paragraph above.

In these Crosley receivers the most common source of trouble is the volume control. The type used is an old Centralab design using a leather washer under the depressor arm; this washer either wears out or turns over. To repair this unit cut a new washer from a thick piece of leather with a harness punch and trim one end to fit the hole in the arm. Loosen both nuts on the unit so that the arm can be pushed far enough out to put the new slider washer in place.

Another common place to look for trouble in these machines is in the bath-tub type tuning condenser. When the rotor gets stuck or tight the owner generally oils it; the result is low volume or none at all. To remedy this condition solder a pig-tail from the end of the shaft to the frame. I find that it is good practice to do this on every set that comes in, as it ordinarily eliminates noises and increases the volume.

NELSON E. GRUBBS,  
Eutaw, Alabama.

## FLASH!

Make your own "talking light beam" transmitter and receiver, as described in detail in the forthcoming issue of RADIO-CRAFT. The author describes an inexpensive and ingenious system that may be built up in a short time by anyone.

## STANDARD RATE CARD

**CLASS A SERVICE — HOME RADIO — \$1.50**  
General inspection and test of set and associated equipment, tuning up tuner and intermediate stages, cleaning and tightening chassis and speaker, polishing cabinet. No material supplied.

**CLASS B SERVICE — HOME OR AUTO RADIO — \$2.50**  
Includes all of class A service, plus the replacement of any minor defective part, such as resistors or by-pass condensers. Material included.

**CLASS C SERVICE — HOME OR AUTO RADIO — \$4.00**  
Includes all of class A service, plus the replacement of any major defective part, such as power transformers, filter condensers, speaker cones and the like. Material extra.

**CLASS D SERVICE — AUTO RADIO — \$6.50**  
Installation of set with running board antenna or in cars already equipped with antenna. Car to be delivered to shop and called for. No material supplied.

**CLASS E SERVICE — ANTENNA INSTALLATION**  
Roof antenna in automobiles ..... \$ 5.00  
Unshielded antenna system for homes ..... 5.00  
Shielded broadcast antenna system for homes ..... 10.00  
Extra outlets for above, each ..... 2.00  
All wave doubler antenna system for homes ..... 12.50  
All material supplied with above, except poles.

**CLASS F SERVICE — SPECIAL SERVICES PER HOUR \$1.50**  
Includes such work as noise elimination in auto sets, tracing and removing interference in home radios and similar work. No material supplied.

**CLASS G SERVICE — HOME RADIO YEARLY MAINTENANCE**  
On any class B or C job, upon payment of \$3.00 extra, a certificate will be given covering the maintenance of the set for one year. Material extra.  
On class B and C service each additional job will be \$1.00.  
A radio will be supplied for your use while your own set is away for an extra charge of \$.50.

**All Work Unconditionally GUARANTEED FOR 90 DAYS;**  
**If It's About Radio Call**  
**F. R. HARRIS**  
70 HOWARD ST. NEWARK, N. J.  
Market 3-2689

MEMBER PHILCO RADIO MANUFACTURERS SERVICE

We reproduce above one Service Man's answer to the "50c per call" racket. Fair prices on his card do the trick for Mr. Harris.

Now  
**SIMPLIFIED**  
and **IMPROVED**

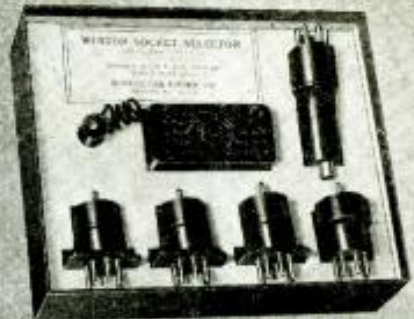

**WESTON**  
**SOCKET**  
**SELECTOR**

MODEL 666, TYPE 1A

The method of Selective Analysis, introduced by Weston, has been further improved and simplified. Now . . . only one socket selector cord and plug is necessary — colored special adapter combinations provide for 6, 5, 4 and large 7-prong tubes.

Model 666 makes any analyzer truly universal in its capacity to analyze radio receivers. Combined with the Weston Model 665 Volt-Ohm-Milliammeter it provides a method of analysis which banishes obsolescence. You will want full data on Model 666, type 1A. Return the coupon today . . . Weston Electrical Instrument Corporation, 599 Frelinghuysen Ave., Newark, N. J.

**WESTON**  
*Radio Instruments*

Weston Electrical Instrument Corporation  
599 Frelinghuysen Ave., Newark, N. J.

Send Name \_\_\_\_\_  
Bulletin on Weston Radio Instruments \_\_\_\_\_  
Address \_\_\_\_\_  
City and State \_\_\_\_\_

# HERE'S *Something!*

A high quality Midget Portable Public Address System for \$59.50 list price. Only three tubes—but how they can push sound out of the big eight inch dynamic speaker!

High gain—low hum—natural tone reproduction—phonograph input—double button mike—light in weight—inexpensive—everything you could ask for in a small portable.

## IF YOU ARE A SOUND EQUIPMENT DEALER

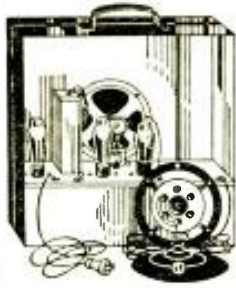

Midget (Inside View)

Don't fail to write for the U.S.E. Short-Cut Catalog, illustrating a complete line of public address units, and for special circulars that will help you sell prospective customers.

U.S.E. offers you a complete, highly competitive line of amplifying equipment. Place yourself in a position to meet competition on sound installations by demonstrating and selling U.S.E. Whether it's on price or performance, you will have the advantage.



Front

## United Sound Engineering Company

Manufacturers of Specialized Sound Equipment

2233 UNIVERSITY AVENUE

SAINT PAUL, MINN.

## WANTED!

Jobbers—Mail Order Houses and Representatives in all Territories

### TWO FAST MOVERS



Free Edge Cone and Voice Coil Assemblies Dynamic Speakers  
We also Manufacture Various Types of Magnetic Speakers  
We can Supply and Remedy Your Speaker Needs. Speaker Mfrs. Since 1921  
LEOTONE RADIO CO., 63 Dey St., New York, N.Y.

## Something NEW for RADIO MEN!

### ALPHABETICALLY INDEXED RADIO SERVICE NOTES

We have expertly prepared in alphabetical arrangement and carefully indexed, specialist's service notes which give pertinent facts about sixty-five different standard receivers. This material, conveniently arranged, enables you to quickly select from your files, cards which tell how to correct intermittent reception, hum, distortion, oscillation, superheterodyne alignment, speaker trouble, cross modulation, balancing, power pack failures, poor DX reception and dozens of other common radio faults.

Our Consultation Bureau gives you FREE authoritative information of all radio service problems. In addition, it provides for sales promotional ideas, advertising—everything to make the servicing business profitable.

For complete details about these "Indexed Service Notes," write today for circular RC-4.

CAPITOL RADIO RESEARCH LABORATORIES  
711 Barr Building Washington, D.C.

## FREE 1934 RADIO CATALOG

BARGAINS GALORE FOR DEALERS — SERVICEMEN — AMATEURS

Important News for Radio Men:  
**HANDY SERVICE MANUAL**  
128 Pages of Important Information Regularly \$1.00  
For Limited Time Only **25¢**

**TRY-MO RADIO CO., Inc.**  
65 CORTLANDT ST., Dept. C-4 NEW YORK CITY

## RADIO SET PRINTS NEWSPAPER

(Continued from page 618)

The average number of lines used at present is 100 per inch but, with the present machines, the number can be increased up to 300; this maximum number of lines is practically never used, as there is at present no call for such fine-quality reproduction.

This is simply mentioned to show how far this art has already advanced, and what has actually been accomplished.

A recent announcement by RCA states that it is now prepared to send telegrams in facsimile all over the country. In other words, you write in longhand a telegram in which you can incorporate sketches if you wish, and RCA will transmit such telegrams, handwriting, sketches and all, at a low rate. RCA, however, stresses the point that, so far as its service is concerned, this ultra-short wave high-speed facsimile apparatus is to be a purely point-to-point proposition, open for public use in the transmission of pictures, messages, bank statements, etc.

In my present project, the only new thing which I show is the use of a double system of ink-vapor jets which operate simultaneously, one on each side of the paper sheet. Use is made of a doubly-modulated wave, similar to what was used two years ago by the Columbia Broadcasting System to broadcast both sound and sight on one wavelength. This method would seem perfectly feasible in connection with the ink-vapor jet arrangement; but some further experimenting must be done to get down to the fine points. No great technical difficulties, however, are foreseen in solving this particular point.

As far as the owner of the set is concerned, the action of the printing device is wholly automatic; all that he needs do is to renew the roll of paper once in a while, get a new air-pressure charge in the tank, and a fresh ink bottle. The air-pressure tank can be taken to the nearest garage, where compressed air can be furnished; or, more likely, Service Men of the future will call once a month and take care of the renewals of paper, ink and air bottle. Some little cleaning of the air-brushes (for ink) and other details will be taken care of by the Service Men who, for a small fee, will give a monthly routine inspection to the set.

The different illustrations which I present are self-explanatory, and they show all the necessary details for the interpretation of this new art. Several photographs of the RCA machine which is now in use have also been added.

## RAISING THE OHMMETER RANGE

T. B. Taylor

HAVING a "direct reading" ohmmeter, we reasoned that if we could establish the amount of current flowing in the ohmmeter circuit at its various "ohm readings," we could use a voltage-multiplying resistor, external to the meter, and thereby obtain a two-purpose meter.

Our first move toward this, was to observe the "ohm reading" marked at CENTER of the scale. In our particular instrument, powered by one 1.5 V. battery, the "ohm reading" is 5,000 ohms. From the above we can determine the full-scale current of the meter by dividing the voltage, 1.5, by "ohm reading" 5,000 and obtain .0003. So far, this information tells us that our instrument is entirely satisfactory for use as a "high-resistance-per-volt" meter. The computed resistance-per-volt (5,000 ohms divided by 1.5 V.) is 3,333 1/3 ohms.

Now, to establish the meter current values at the various "ohm readings." We will select as example, an "ohm reading" of 10,000. To this figure ADD 5,000 ohms, the value of the resistor which is placed between the meter and the voltage supply to limit the circuit current to full-scale current reading or "zero" ohm reading; the total then is 15,000 ohms. By dividing voltage, (1.5) by ohms, (15,000) the quotient is .0001-A. (The dial "ohm reading" of 10,000 thus indicates the .0001-A.)

For voltmeter operation, we wished the full-scale range of our voltmeter to be 450. The necessary external voltage multiplying resistor value was computed as 1,500,000 ohms, obtained by dividing desired voltage range (450) by FULL SCALE current of the meter, (.0003-A.).

The watts rating of the voltage-multiplying resistor is obtained by squaring the full-scale current (.0003 times .0003) the product being .00000009. This being multiplied by the value of the voltage-multiplying resistor (1,500,000) gives .135 as the watts rating for the resistor. A 1,500,000 ohm resistor of 0.5-W. rating or higher, would be satisfactory.

We now want to know the voltage being read when the meter indicates "ohm reading" 10,000 when the meter current is computed as .0001-A. The voltage being read is 150, obtained by multiplying circuit resistance (1,500,000 ohms) by circuit current (.0001-A.).

Each "ohm reading" of the meter scale may be calibrated as to meter current; or, if only one voltage range is desired, the "ohm readings" may be calibrated as voltage readings.

You will note in the circuit of the ohmmeter, one test prod is directly connected to meter terminal, say "negative," and this prod may be used as "negative" of voltmeter. One end of the voltage multiplying resistor is connected directly to opposite terminal of meter, which would then be "positive." The positive test prod of the voltmeter connects to opposite end of the resistor.

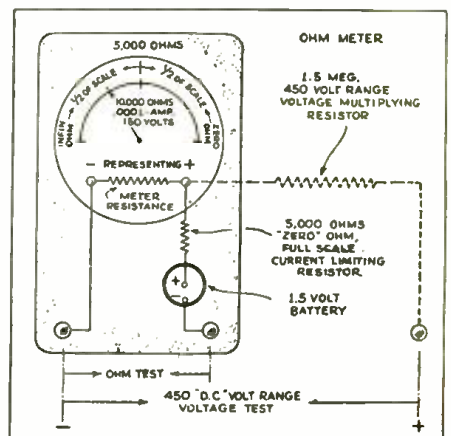

Fig. 1

Details for revamping the ohmmeter.



# FACTS ABOUT DYNATRON OPERATION

(Continued from page 598)

one has an output meter, the R.F. oscillator circuit described already can be used "as is." If a modulated signal is desired, the reader is respectfully referred to an article on page 464 of the February, 1931 edition of RADIO-CRAFT for details. The writer has a beat-frequency oscillator which primarily consists of a dynatron oscillator functioning at a fixed frequency and a second dynatron oscillator which has a variable tuning adjustment operating through a narrow band of frequencies. By varying the tuning condenser the two oscillators are caused to produce "beat" notes which are passed on to a detector, and through an A.F. amplifier system to a phono. pickup. This device can produce audio frequencies from something like 30 cycles on up to about 10 kc. and is an application of the dynatron circuit to the measurement of audio-frequency apparatus. One use in particular to which this apparatus can be put—and one which is not frequently given a thought by the Service Man—is the subject of loudspeaker resonance (this can be determined with the beat-frequency oscillator mentioned).

Another example of the utility of the dynatron oscillator lies in its application to the study of code telegraphy; a circuit for this purpose was shown in RADIO-CRAFT in November, 1932, page 279. For the benefit of any who may be interested in the use of the dynatron as a frequency changer in the superheterodyne circuit the reader is referred to the circuit shown on page 676 of the May, 1931 edition of RADIO-CRAFT. As already mentioned, there are limitations to the application of the dynatron principle in vacuum tube operation and this is the reason for its not having been put to more general use, commercially. In order to function as a good dynatron, a tube must have elements that are clean and bright, as the secondary emission is ordinarily at a maximum under such conditions, however, with the attendant heating of the elements. Therefore, a tube which may be an excellent dynatron tube, when new, may not be at all satisfactory for this purpose after it has been in use for a time. The thinking and farsighted engineer engaged in designing apparatus for sale to the public has not "taken up" with the dynatron. One application of the dynatron, however, as an oscillator, is in the case of one of the ultradyne circuits which were developed by the late Robt. E. Laeault and in which the dynatron was used as a superheterodyne oscillator.

Owing to the fact that it was something of a problem, in the course of tube operation in general, to control secondary emission, tube manufacturers have endeavored to get away from the difficulty, as far as reasonably convenient, by spraying their tube elements with carbon. For this reason, not many of the tubes made today are very good when used in dynatron circuits, except as they may be picked, one at a time, in the shop or laboratory, and tested for their individual adaptability for use in circuits of the type being considered. (Any who desire some information pertaining to the spraying of tube elements with carbon are referred to the September, 1932 edition of RADIO-CRAFT.) The individual Service Man or experimenter should have little difficulty in picking out an occasional tube for such use, considering the number of tubes that pass through his hands from time to time. (Incidentally, it is proper to note that the dynatron property of tube operation which gives rise to a decrease in plate current with an increase of plate voltage is sometimes termed "negative resistance." That portion of the characteristic curve already studied which reflects this feature of tube operation is sometimes referred to as the "negative resistance" portion of the curve. When a tube is operating under such conditions it is referred to as functioning in the "dynatron region," and when making a laboratory set-up for the use of a tube as a dynatron it is desirable to adjust the applied voltages so that the tube is operating somewhere near the middle of the "dynatron region").

## The Dynatron as a Detector

As a detector the dynatron has possibilities, although this is something more or less in the experimental stage at the present time. Studies of this subject made thus far, indicate that good reception is possible with a dynatron detector circuit and for those who may desire to try it out, the circuit diagram shown in Fig. 8 is offered.

The grid leak type of detection does not satisfactorily apply to dynatron detector application, rather a bias is best used in the circuit between the grid and the cathode or filament, as the case may be. Commonly this grid bias will be found to be some value within the resistance range from about 75,000 ohms to .75-megohm, however it varies more or less from tube to tube and no one value can be definitely assigned, offhand. It is pertinent to emphasize the fact that this biasing resistance value, for any given tube, is decidedly critical. As a means of determining the value for a chosen tube (after having run a test on the tube in order to determine definitely as to whether or not it is adaptable to dynatron circuit requirements) it is suggested that a variable resistance be used in determining the critical value of the bias and when this has been determined by experiment—measure the resistance value and then substitute an accurate fixed resistance for the variable resistor.

Tuning of a dynatron detector circuit is largely a matter of tuning the midjet variable condenser in the aerial circuit, although it is important to have an inductance in the plate circuit which is of a value corresponding to the frequency range to be received by the detector. Otherwise the experimenter may find himself listening to several stations at one time. The dynatron as a detector seems to possess considerable possibilities when applied to the reception of short waves, and the writer suggests this as a subject for experiment by those who may be interested. It should be kept in mind that the sensitivity of this circuit depends largely upon the careful manipulation of the biasing resistor, for it acts as a control on regeneration.

## The Dynatron as an R.F. Amplifier

Most of what has been published regarding the dynatron circuit heretofore has pertained to its application as an oscillator, although limited references have been made to its use in detecting and amplifying circuits. The writer has been interested for years in practical, workable, and at the same time simple, R.F. amplifiers. Therefore it was quite in keeping with dynatron circuit investigation to experiment with the thought in mind of determining its utility as an R.F. amplifier. The circuit employed is that of the ordinary resistance-coupled amplifier with a lower voltage impressed upon the plate than that which is applied to the screen-grid. It should be kept in mind at all times that the circuit has a tendency to oscillate, and resistor and voltage values which will permit the circuit to function without introducing objectionable oscillation must be used. The circuit arrangement of a one-stage amplifier is shown in Fig. 9.

An interesting experiment has been conducted by connecting the oscillator whose circuit is indicated in Fig. 7 to the input of a receiver of the T.R.F. type, precisely as if the tuning condensers were to be lined up. By adjusting the oscillator condenser so as to beat with the receiver when the latter is tuned to a given station and at the same time controlling oscillation by the potentiometer, it has been found that in certain instances the receiver output volume has been at least doubled. With such an arrangement, too, it has been noted that broadcast stations were heard which could not be heard at all without the oscillator; or at least if they were heard, it was not possible to separate them. This applies particularly to stations in the "graveyard" division of the wavelength allocation. Thoughtful consideration of this application of the circuit being considered will make it plain that provided oscillations are properly controlled, we have in such a circuit an application of the tuned-plate, capacity-coupled amplifier. While it may be regarded as unstable, it has been found that it can be made to work under certain conditions, and that very naturally helps to satisfy aroused curiosity.

(Continued on page 627)



**New Direct Reading Tube Tester Simplifies Tube Testing**



**N**O longer need you reassure a skeptical customer as to the worth of a tube. The position of the meter needle on the shaded 2-color scale, indicates to what degree a tube is either poor or good. When you use the Readrite 419 tester, you can see this for yourself.

This newer and better instrument is used by both dealers and service men to check new and old tubes . . . on the counter or out in the field. It makes tube testing so simple, so easy, so quick . . . that anyone can operate it. Selling tubes is made easy! Has only two selector switches—one for heater volts and the other for the type of tube. No confusion. No multiplicity of operations.

A push button provides two plate current readings for determining the conductance and worth of a tube. The correct tube filament voltages applied are: 1½, 2, 2½, 3.3, 5, 6.3, 7.5, 12.6 and 25. (Comes in Oak case.)

**YOUR JOBBER  
CAN SUPPLY YOU**

at the dealer's net price of \$24.00. See him today.

**Readrite  
Meter Works**



106 COLLEGE AVENUE  
BUFFTON, OHIO

**SEND COUPON FOR FACTS**

**READRITE METER WORKS**  
106 College Avenue  
Buffton, Ohio

Gentlemen: Send me catalog on Readrite Tester No. 419 and complete line of radio servicing instruments.

Name .....

Street Address .....

City ..... State .....



## It STOOD a Test! Brings Surprising Results

Rough going in wintry weather—through mountains in New York State, this 6-tube Superheterodyne proved a mighty sturdy Auto-Radio. Hard bumps, slippery roads, hills never interrupted reception during a long steady drive.



Automatic volume control—Interstation noise suppression—New Pentagrid converter tube—8 tube performance—but uses only six (1/6A7 1/41 1/75 2/74 1/84 tubes)—Illuminated vernier airplane dial—Power lock switch—Dynamic speaker—Only 2 wires to connect—Quickly installed—190 to 550 meters—Use any type aerial—Drains only 4 amperes—Size 8 3/4" x 6 1/2" high—Rugged—Powerful—Selective. Complete in one unit—Guaranteed for one year—sold with genuine R. C. A. tubes, dynamic speaker. Complete, ready to operate. Immediate deliveries.

Net To Dealers \$27.95 and Servicemen \$19.95 Beautiful Walnut Cabinet \$2.50

Send stamp for pamphlet showing complete line of AC-DC and All-Wave Receivers.

STATES RADIO LABS, 137R Liberty St. New York, N. Y.

### AIR CELL SUPER

States New Air Cell superheterodyne consumes 20 mls "B" and 5 amp's "A" Emphases 1-1A6, 1-19, 1-30, 1-32, 1-34—RCA licensed—Distant reception—Powerful—Economical—E or I arm, Home or Boat. Size 9 3/4" wide x 8" high x 1 1/2" deep. Complete chassis with tubes, speaker, less batteries.

Net to Dealers \$19.95 Beautiful Walnut Cabinet \$2.50

## HEADPHONES COMING BACK

(Continued from page 606)

includes some really new and distinct features is shown in the accompanying photograph. A toggle switch for selecting either phone or loudspeaker reception is included. Two tip jacks are mounted in the side of this adapter and into these the phone cord connects. This unit can be employed in either the first audio or power stage (where single tube power stage is employed) depending upon the amount of volume the listener desires or can stand. It replaces the tube in either of the aforementioned tube sockets, and the tube itself is then plugged into the top of the adapter where a conventional socket is mounted. A few words of precaution are necessary at this point. When selecting the adapter, the type of tube it is to replace must be considered since the number of prongs on this unit must conform to the number on the tube.

There are, of course, other types of devices which will permit headphone use—most of them being built along the lines of wafer sockets which fit over the tube prongs, connections being made by eyelets through which the prongs pass. This type will also be found satisfactory although the innovations described for the first adapter are not included.

Incidentally, if any intensive listening-in with headphones is going to be done, the listener would do well to obtain and use a pair of lightweight phones. Unless one happens to be a commercial or amateur operator and accustomed to wearing phones for a considerable period of time, it is surprising how quickly the ears become fatigued.

## A KNOCKABOUT TESTER

(Continued from page 604)

range is 20.83 ohms. For the 75 ma. range, 6.75 ohms is required.

To make this shunt correctly, the following is the procedure: secure a 25 ohm resistor and place the extra clip at approximately one-fourth the distance from one end, and adjust to 6.75 ohms. Then adjust the other end so that the resistance is 20.83 ohms from one end to the other. Do not calibrate the 20.83 ohm section first. The double-pole double-throw switch used must have an off position.

In the ohmmeter circuit (see diagram) the 2,500 resistor is only used as a limiting device and need not be accurate. The variable resistor compensates for high or low batteries from the discarding point of 2 1/2 V. to 3 1/2 V. The panel was designed to fit an easily obtained card file box. The inside dimensions of this box are 5 1/2 x 5 3/4 x 3 1/2 ins. high, although the height is not important and may vary with different file-card boxes.

The diagram is very simple, and the parts easily obtained. There is no reason why this kit of parts, including the meter and a drilled and engraved panel should cost over \$10.00.

### List of Parts

- One Beede 1 ma. meter with combination scale;
- One drilled and engraved bakelite panel: 5 1/2 x 5 3/4 x 1/4-in.;
- One Lynch 450 ohm resistor, 2% accuracy;
- One Lynch 5,000 ohm resistor, 2% accuracy;
- One Lynch .25-meg. resistor, 2% accuracy;
- One Lynch .5-meg. resistor, 2% accuracy;
- One Lynch 2,500 ohm resistor;
- One Electrad 1000 ohm variable resistor;
- One Electrad 25 ohm resistor with extra clip, 10 W. type;
- One type 762 D.P.D.T. switch;
- Seven tip jacks.

## Third Dimension in Sound

If you think you have heard the ultimate in sound realism, read about the latest Bell Labs. system in the forthcoming issue of RADIO-CRAFT.

## MODERNIZE Your Analyzer

Why be handicapped when an ancient analyzer when in two hours you can easily modernize it with one of these kits and a pair of composite sockets! Directions and diagrams included with all outfits

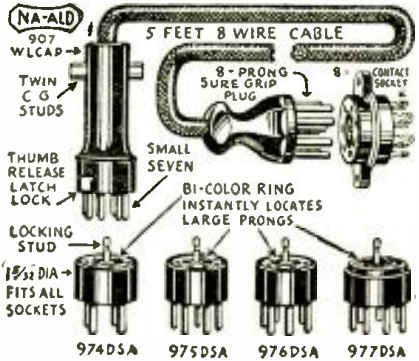

- | Kit       | Description  | List Price |
|-----------|--|------------|
| 907 WLCAP | Small 7 prong Latch Lock Analyzer Plug, 8-wire Cable, Plug and Socket as shown above | \$6.00     |
| 974DSA    | Latch 7 to 4 prong Adapter   | 1.25       |
| 975DSA    | Latch 7 to 5 prong Adapter   | 1.25       |
| 976DSA    | Latch 7 to 6 prong Adapter   | 1.25       |
| 977DSA    | Latch 7 to 7 prong large Adapter   | 1.25       |

- Here is the set for those who want the lowest possible cost. Does not have means for locking the adapters to the plug but is serviceable in every way, the wired adapters having the necessary small base for fitting shielded sockets. C. G. stud supplied.
- | Kit      | Description                      | List Price |
|----------|----------------------------------|------------|
| 977P     | 7-prong Plain-Type Analyzer Plug | \$4.40     |
| 974W     | 7 to 4-prong Wired Adapter       | .55        |
| 975W     | 7 to 5-prong Wired Adapter       | .55        |
| 976W     | 7 to 6-prong Wired Adapter       | .55        |
| 977WA    | 7 to 7A-prong Adapter            | .55        |
| 977P KIT | Complete as shown                | \$2.60     |

- ### NEW ITEMS
- | Item                                  | List Price |
|---------------------------------------|------------|
| 8-Wire Analyzer Cable                 | \$4.10 ft. |
| 456 4-5-6-Hole Comp. Socket           | .50 ea.    |
| 477 7-7A-Hole Comp. Socket            | .50 ea.    |
| 457 5-7-Hole Comp. Socket             | .50 ea.    |
| 487 5-6-7A-Hole Comp. Socket          | .50 ea.    |
| 908S 8-prong Plug (see above)         | .50 ea.    |
| 438S 8-hole Socket (see above)        | .35 ea.    |
| 907DSA 6 to Sm. 7 Latch Adapter       | 1.25 ea.   |
| 855PSC Spkr.-Phones Switching Adapter | 2.50 ea.   |
| 450 50-Watt Socket                    | 1.00 ea.   |
| UX-50 50-Watt to TX Adapter           | 3.50 ea.   |
| 50-7AS Sm. 7 to 50-Watt Adapter       | 3.50 ea.   |

- ### NEW TEST ACCESSORIES
- NEW! A COMPLETE SYSTEMATIZED LINE OF IMPROVED TIP JACKS, CONNECTORS and PLUGS, EXPANDING PRESSURE PLUGS, JACKS and CONNECTORS, EXTENSION and JUNCTION CONNECTORS, TEST PROBES, UNIVERSAL TERMINAL SOCKETS, etc.

New Molded Handles in three styles, Small Spare, Slide Contact and Lame or Short Testing, all interchangeable with the pointed Phone Tip. Expanding Pressure Plugs and Silver Plated Needle Points. Sockets with Universal Terminals for soldering, binding, plug-in and tap-off connections.

Write for new Test Accessories Bulletin listing and describing these new items. Also shows how they may be used to make up test panels, point-to-point testers, experimental and test benches, etc.

### HERE'S THE DATA YOU WANT

Send two 3c stamps for new Bulletin showing illustrated tube socket connections of 268 different tubes, data and diagrams on rewiring any obsolete set analyzer or tube checker and information on using the new tubes in place of old types. Include catalog pages of all kinds of sockets, speaker plugs, connectors, wound and unwound coil forms, coil winding data, S-W receiver references, etc.

Servicemen's Discount ..... 35%  
On orders amounting to \$10.00 List..... 40%

**ALDEN PRODUCTS CO.**  
Dept. R-4, 715 Center St.  
BROCKTON, MASS.

NA-ALD

**JUST OFF THE PRESS!**  
**Free** **1934 RADIO AND AMPLIFIER CATALOG** **MAKE US YOUR HEADQUARTERS FOR PUBLIC ADDRESS AMPLIFIERS**  
Deal DIRECT with Manufacturers and **SAVE BIG MONEY**  
**COAST TO COAST RADIO CORP.**  
133-N WEST 5TH ST., NEW YORK, N.Y.

## Would You Ring 25 Door-Bells for ten dollars?



Dealers and servicemen are earning ten dollars a day by applying the TOBE Junior Line Filterette to noisy radios. A dealer in New York City earned \$150.00 extra last month showing apartment dwellers that line noise can be kept out of the radio. You buy Filterette Junior for \$1.35—sell it for \$2.25—and make a satisfied customer.



Filterette Junior

Ask your jobber or write

**TOBE DEUTSCHMANN CORP.**  
CANTON MASSACHUSETTS

## UNIVERSAL

2-Button Handi-M \$15.00 List

Maximum volume, minimum hiss, scientifically damped. Truly natural tone. No delicate parts to be damaged. For announcing, transmitting or home recording. New catalog covers twelve models from \$5.00 up.

**UNIVERSAL MICROPHONE COMPANY, Ltd.**  
424 Warren Lane  
Inglewood, Calif. U.S.A.



# DYNATRON OPERATION

(Continued from page 625)

## Dynatron A.F. Amplification

The dynatron circuit, resistance-coupled, will function as an A.F. amplifier with very satisfactory results. Such a circuit was shown on page 560 of the March, 1931 edition of RADIO-CRAFT, in an article by Mr. C. H. W. Nason. The writer has used a similar amplifier for some time past, with a type 47 tube connected as a triode. Instead of the 45 output tube suggested by Mr. Nason, the hook-up employed, using the 47 output tube, is shown in Fig. 10. (The substitution of one type of tube for another offers thought for much very interesting study, particularly in the matter of substituting new types of tubes for older ones. For a discussion pertaining to the application of the pentode as a triode see RADIO-CRAFT, July, 1932, page 42).

## Other Uses of the Dynatron Circuit

In addition to the applications of the type of circuit under consideration in this article there are others that are in more or less common use. Of these uses perhaps one of the best known, and least used, is the use of the dynatron circuit in the various applications of the vacuum tube voltmeter. Such a circuit has been considered in the following issues of RADIO-CRAFT: April, 1932, p. 614; November, 1932, p. 285; and March, 1933, p. 545. Another application of the circuit is possible in the case of a radiophone transmitter, although this application has never received very much favorable consideration on the part of those, particularly amateurs, who might be the ones to profit by it in the way of gaining experience and practice in its applications.

The writer has constructed an experimental substitute for the common doorbell by arranging an oscillator so that when the push-button is depressed a musical note is emitted by a single headphone connected in series with the plate inductance. This coil by the way, is tuned with a fixed condenser and the audible output is somewhat musical in tone. The circuit is essentially the same as that shown in Mr. Pollack's article, in Fig. 1, on page 464 of the February, 1931 issue of RADIO-CRAFT, with the addition of the push-button which is in series with the filament-heating battery.

The use of the dynatron circuit in frequency meter construction has not been directly referred to heretofore in this article. However, such an application of the circuit is possible and convenient. The construction of such a device is very similar to that involved in making an oscillator for laboratory or service work. In fact the same device may be used for either purpose with but slight changes. In one case, the instrument emits a signal at a pre-determined frequency, while in the other it is used to determine the frequency of a signal generated by some other source.

## Conclusions

From what is known of the dynatron circuit at the present time, it may be said that the principle involved is one that is readily workable and requires a minimum of apparatus. As pointed out, the subject of secondary emission is one for study and owing to the difficulty involved in controlling such emission the tube manufacturers have been treating their tube elements with carbon for some time past, as it has been found by most manufacturers of tubes to their regret, that

the negative "shielding" effect resulting from the use of bright tube elements caused more or less difficulty in the functioning of tubes in the usual run of receiver circuits. From this it may be inferred that the dynatron circuit is not likely to find much application in commercial receivers for some time to come. This, however, need not deter the student and experimentally inclined Service Man from investigating the merits of so simple, useful and practical a circuit. There need be little hesitancy on the part of the experimenter as to the availability of an occasional tube with which to conduct such an investigation. Most of the type 15, 22, 24, 32, 35, 51 and 865 (the latter being a low power, screen-grid transmitting tube of 12½ W. rating), and some 2A3 tubes, will function in dynatron circuits very satisfactorily. It must be kept in mind that tubes employed in dynatron circuits, because of the varying conditions surrounding the subject of secondary emission, will not act uniformly when one is compared with another of similar type. Neither will a given tube necessarily function under a given set of conditions throughout its normal life. This, however, should have little bearing on such uses as the amateur, experimenter, student or Service Man is likely to subject the tube to. That the dynatron circuit is possessed of much merit is without question. That it has its limitations is also true. However, the man who makes a study of it need not feel that his time is being wasted and it should be remembered that he may find himself well rewarded through the acquisition of useful information.

An investigation of the properties of the dynatron circuit should not be regarded as complete without reference to some good works pertaining to the subject of tubes in general, together with their applications.

## Bibliography

- Q. S. T., February, 1930, page 33: The Dynatron.
- Q. S. T., July, 1930, page 39: Impedance Measurement with Triodynatron.
- Q. S. T., September, 1930, page 21: Bringing Frequency Measurement Up to Date.
- Q. S. T., October, 1930, page 9: The Dynatron Frequency Meter.
- RADIO-NEWS, Jan., 1932, page 580: Beat-Frequency Oscillator.
- RADIO NEWS, Sept., 1932, page 167: Universal A.C. Dynatron Oscillator.
- RADIO NEWS, Sept., 1933, page 188: An A.C. Operated Dynatron Oscillator.
- RADIO WORLD, July 18, 1931, page 6: Dynatron Detector Circuit.
- RADIO WORLD, Aug. 15, 1931, page 15: Dynatron Oscillator Uses.
- RADIO WORLD, Sept. 5, 1931, page 14: A Deluxe Oscillator.
- EXPERIMENTAL WIRELESS AND WIRELESS ENGINEER (London), November, 1931: The Dynatron Oscillator.
- I. R. E. PROCEEDINGS, Feb., 1918: The Dynatron.
- I. R. E. PROCEEDINGS, Mar. 1922: The Dynatron Detector.
- CHAFFEE, E. L. (McGraw-Hill): Theory of Receiving Tubes.
- MORDEKAI, J. H. (Wiley): Principles of Radio Communication; Elements of Radio Communication.
- MOYER AND WESTRELL (McGraw-Hill): Radio Receiving Tubes.
- R.C.A.-CUNNINGHAM: Radio Tube Manual.
- TERMAN, FREDERICK E. (McGraw-Hill): Radio Engineering.
- PETERS, LEO J. (McGraw-Hill): Thermionic Vacuum Tube Circuits.
- VAN DER BIJL, H. J. (McGraw-Hill): Thermionic Vacuum Tubes.

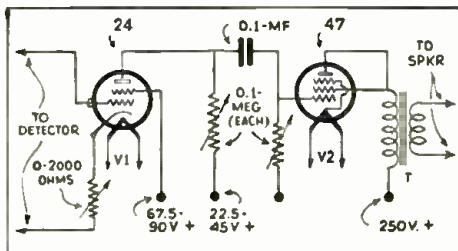

Fig. 10  
A dynatron A. F. amplifier.

**BATTERY SET  
OF HIGH SENSITIVITY**

In the forthcoming May issue of RADIO-CRAFT will appear complete construction details of a battery set of extreme sensitivity. You have been waiting a long time for a good set design, using the new battery tubes—now, here it is!

# 250 SHORT-CUTS to Profitable Servicing!



**FREE** SYLVANIA HANDBOOK TELLS PRACTICAL WAYS TO FIND AND REPAIR TROUBLES QUICKLY!

You've never had a chance like this to get the straight dope on how other good service men solve tough problems! Sylvania's 64-page booklet "Service Hints" gives you the *best* from thousands of practical methods that have been sent to us. Helpful tips on servicing 43 popular makes of radios... on more than 200 different models! Also, useful formulas and complete Interchangeable Tube Chart. Mail the coupon *today* and get your copy promptly. We'll put your name on the mailing list for our FREE monthly "Service Bulletin," too. It gives additional tips and news of the industry.

## HYGRADE SYLVANIA CORP.

Makers of SYLVANIA TUBES and HYGRADE LAMPS  
ELECTRONIC DEVICES

Factories: EMPORIUM, PA. ST. MARYS, PA.  
SALEM, MASS. CLIFTON, N. J.

© U. S. Corp., 1934



HYGRADE SYLVANIA CORPORATION B-9  
Emporium, Penna.  
Please send me your free booklet "Service Hints" and your free monthly Service Bulletin.

NAME .....

ADDRESS .....

CITY ..... STATE .....

# BIG DISCOUNTS TREMENDOUS SAVINGS!

Get Our Monthly Bargain Bulletin



## FREE

IT'S CHOCK-FULL OF  
BARGAINS FOR YOU

You can't afford to be without this book. It offers marvelous buys in Radio Sets, Long and Short Wave Apparatus, Servicemen's Repair and Replacement Parts, Electrical Goods, Sporting Goods—hundreds of miscellaneous bargains.

Be among the first to have the pick of great bargains. Latest issue just out. Act quick. Send coupon and receive your copy by return mail.

RADIO CIRCULAR CO., INC.

225 Varick Street  
New York, N. Y.

Dept. RC-434

Please send me free of charge and without obligation, your latest catalog.

Name .....

Address .....

City .....State .....

## STEWART-WARNER FACTORY CO-OPERATION FOR SERVICE MEN

Service meetings will be held all over the country by special factory radio field engineers. Complete diagram talk on new as well as old Stewart-Warner circuits will show you the easy way to service Stewart Warner radio sets. Service manuals on all new Home and Auto Sets will be given free.

For time and place of meeting, write

Service Department

**STEWART-WARNER CORP.**

1826 Diversey Parkway - - Chicago

## TRIOLET Meters

No. 1167 Free Point Set Analyzer

Our Net Price \$24.50

No. 1179 Perpetual Tester . \$33.98

We carry the complete line. Call or write for descriptive bulletin.



45D VESEY STREET New York, N. Y.

NEW! SENSATIONAL!

## 110 VOLTS AC FOR AUTOS

The new AUTONATOR generates 110 Volt A.C. Current in motor cars, aeroplanes and from all types of engines and motors, direct from fan belt. Costs nothing to operate. No service—no brushes, collector rings, commutator or wire wound armature. Ideal for operating PORTABLE Sound Equipment, A.C. Radio Sets, Neon Signs, Electric Lights, Search-lights. Send for complete details.

**AUTONATOR LABORATORIES, INC.**

8440 South Chicago Ave. Dept. A Chicago, Ill.

## A NEW METHOD FOR AUTO-NOISE ELIMINATION

(Continued from page 600)

factor would certainly never be used. And, here we find the "proof of the pudding" since, surprising as it may seem to a great many, no form of suppressor device is ever employed for eliminating ignition noise from aircraft radio reception. Instead the simple method of complete shielding of all high- and low-tension cables and shielded spark plugs is employed. And also, strange as it may seem to auto-radio installers, this procedure works out quite satisfactorily and is all that is necessary to eliminate the interference. Again the installer is referred to the Butek type of installation where no (spark plug) suppressors are necessary due to the complete seclusion and shielding of the plugs by a metal plate that encloses them, as proof that this procedure will work out just as well in auto radio practice.

### Airplane System

In airplane work a shielded plug such as that shown in Fig. A is generally employed. There are, of course, some variations in the design of this unit as made by various manufacturers, but substantially the principle of completely enclosing or shielding the plug and cable leading to it is incorporated in all of them. In airplane work the shielded ignition cables are made up complete for the various types of motors that are generally employed for plane use. However, the Packard Electric Corp. makes up a form of woven metal shielding that slips over the cables of non-standard installations. Unfortunately, there are no automotive equipment manufacturers that supply a shielded plug for automobile use. This is probably due to the fact that while plug sizes are pretty well standardized in airplane motors to a very few types, in automobiles there are well over fifty types and sizes. However, when, and if there is ever a demand for an auto plug of this type, it is safe to assume that the manufacturers will respond by bringing such units on the market.

### A New Idea

Meanwhile a suggested substitute, in the form of a wrinkle, is shown in Fig. B. A coil or tube shield of the required height is adaptable for this purpose. If a coil can be used, the bottom should have a hole drilled equal in size to the diameter of the threaded portion of the plug. The plug is then inserted into the shield with the threaded area protruding through the opening that was drilled for it. It can then be inserted into its respective cylinder and by means of a spark plug socket wrench screwed down tightly so that the shoulder of the plug locks the shield against the cylinder head and automatically grounds it. It would, of course, be good policy to first scrape the metal area against which the shield would contact to insure a good ground connection. The cover of this can must also be drilled to permit the cable leading to the plug to go through it. The shielded loom or braid that fits over the spark plug cable must be soldered to this cover and should cover the cable to the point where it reaches the tubing or housing above the cylinder head. At this point all shielded cable should be bonded and grounded. Where the wires leave the housing and go to the distributor head, the procedure of shielding each individual cable should be continued. A clearance of approximately 1/2-in. must exist between the distributor head terminals and the shielded loom or braid, otherwise there will be a flashover discharge caused by the high voltage from the terminal to shield (which is equivalent to ground), and which would prevent the motor from functioning properly. Similarly, the high-tension lead from the spark coil to the center terminal of the distributor must be shielded with the same precautions, as mentioned previously, in mind.

The regular procedure of bonding and grounding all cables, oil or gas line pipes, or any other metal tubing which may come through the "fireboard" (that is the wall which separates the motor compartment from the instrument-board space) should be per-

formed or else there might be some interference radiated by these lines due to stray R.F. currents that the shielding does not take care of.

### Additional Shielding

Low-tension wires in the motor compartment, particularly the one leading to the breaker points, should also be shielded if completely satisfactory results are desired. Remember to ground all shielding, preferably to a heavy metal braid that is bolted to some portion of the girder construction supporting the body of the car and which is brought up to the motor and secured there. This is to insure a better motor ground, especially desired where the motor is mounted on rubber blocks to minimize vibration. Even though the motor will be found to be grounded in a case of this sort because of the bolts which hold it down, it should be considered that the motor will rock when it is running or when it is suddenly accelerated, causing an imperfect ground contact due to the fact that the bolts are not "taken up" tightly so that this rocking or vibration could be taken care of by the rubber blocks.

## A NEW "LIGHT METER"

A "RIGHT LIGHT" METER for measuring light intensities and making illumination surveys is announced by the Westinghouse Electric and Manufacturing Company. Only a few seconds are needed to check lighting conditions at any point, since the dial is marked in foot-candles with zones denoting the minimum amount of light needed for specific types of work.

The following are among useful applications of the "right light" meter:

- (1) Checking intensities on dull days when natural light fails;
- (2) Checking the efficiency of artificial lighting installations;
- (3) Indicating when higher candle power lamps are required or when fixtures need cleaning;
- (4) Surveying the condition of walls and ceilings which may prevent proper reflection of light;
- (5) Determining the efficiency of lamps which may be of old design or worn out and in need of replacement;

The new foot-candle meter embodies many unusual features. It uses the new Westinghouse Photocell, a recently developed copper-oxide photo-voltaic cell, which changes light directly to electric current without any auxiliary electrical supply.

## Public Address

NOW

### the money-making field

The only independent manufacturer of complete outfits from

#### THE MICROPHONE TO THE HORN

A few of the items we manufacture are as follows:

Carbon, Condenser and Velocity Microphones; Microphone Stands; Mixers; Pre-Amplifiers; Amplifiers, Hi-Gain, etc.; Portable Outfits; Matching Transformers; Field Coils and Chokes; Power Transformers; Field Exciters; Rectifying Units and Voltage Regulators.



"BF" MICROPHONE

2 - Button, Heavy Duty, Chromium Plated Microphones, similar in appearance and Performance to Mikes listing at \$25.00. Money refunded if not satisfactory.  
**NET PRICE \$4.95**

Send 3c stamp for our new 1934 Catalogue

Radio and Amplifier Laboratories

291 EAST 137th STREET NEW YORK, N. Y.



# FREE!

## Choice of One or More of These Popular Short Wave Books

Here's money put right into your pocket—here's a saving you never gave a thought to. You get absolutely FREE any one or more of the regular 25c and 50c short wave books with a year's subscription to SHORT WAVE CRAFT, the Radio Experimenter's Magazine. A one year's subscription brings you one fifty cent book or two twenty-five cent books; a two-year subscription brings you two fifty cent books and any one twenty-five cent book. Decide NOW what books are most necessary to you—then send us your subscription by return mail. The books will be sent to you immediately.

25¢ The Copy

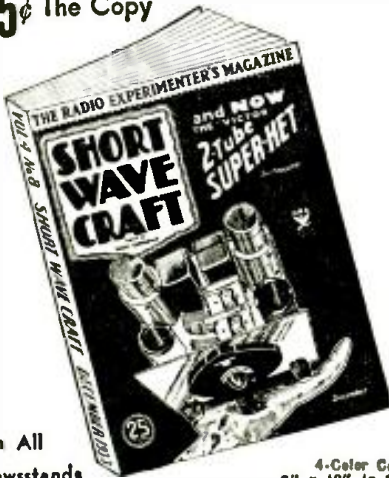

On All Newsstands

4-Color Cover  
9" x 12" in Size  
Over 200 Illustrations



No. 1 50c No. 2 50c No. 3 25c No. 4 25c

THIS popular short-wave magazine interests the great army of "hams," broadcast listeners, and general radio students who are interested in experimental as well as scientific angles of short wave development and application. In each monthly issue appears the largest and most correct short-wave station call list, and important construction articles on receivers and transmitters, including "nicitized" diagrams easily understood by anyone, a big feature "originated" by SHORT WAVE CRAFT. You'll also find the latest news about short-wave physics, micro- and ultra-short waves and other applications of this newest branch of radio.

### Many Short Wave Sets to Build

Many excellent short-wave sets with complete construction details with "picture" diagrams, are found in every issue—these sets vary from simple one- and two-tube sets to those of more advanced design, five and eight tubes.

### Big Silver Trophy FREE!

Recently inaugurated by Mr. Huko Gernsback, Editor, was the "Short Wave Scout Contest." To the Short-Wave "fan" who has logged and obtained verification of the largest number of short-wave stations from all over the world, during one month, will be awarded a magnificent silver Short Wave Scout Trophy.

### Mail This Coupon Today!

SHORT WAVE CRAFT, Dept. RC-434  
96-98 Park Place, New York, N. Y.  
Gentlemen: Enclosed you will find my remittance for a subscription to SHORT WAVE CRAFT for  
[ ] One Year @ \$2.50 (Canadian and foreign \$3.00)  
[ ] Two Years @ \$5.00 (Canadian and foreign \$6.00)  
Send me FREE books which are circled below.

1 2 3 4

Name .....

Address .....

City ..... State .....

(Send remittance in check or money order. Register letter if it contains cash or unused U. S. Postage Stamps.)

## HIGH-FREQUENCY ADJUSTMENTS IN RADIO RECEIVERS

(Continued from page 612)

5. Set the receiver to around 1,400 kc. using a station or oscillator signal as before and completely readjust all trimmers just as for items 3 and 4 above.

If no readjustment is required at either 1000 or 1,400 kc. no further attention need be given the set as far as alignment of the tuned stages is concerned. If considerable, or even appreciable adjustment is necessary, on either 1000 or 1,400 kc. further work must be done as it naturally follows that readjustment at one dial setting will mean maladjustment at another. Nothing can be done about this condition unless the condenser is provided with "alignment leaves." These are formed by slotting the outer rotor plates on one or both ends of each condenser in several places to form fan shaped segments. This arrangement provides a means of changing the capacity over one particular band (usually 100 kc.) without disturbing it at any other band. In some receivers thumb screws are provided to bend these leaves toward or away from the outside stator plate. In others they must be bent either way by pressure of the finger or by use of an insulating rod.

The following is the correct procedure for bending these leaves:

1. When you find that the trimmers must be readjusted at 1000 and 1,500 kc. set the main dial to around 1000 kc. and adjust the trimmers as accurately as possible for peak response as before.

2. Now reset the dial to 600 kc. and readjust for maximum response by bending the leaves toward or away from the stators as necessary. At 600 kc. the plates will be almost fully in mesh and those leaves which will come out first (the largest ones) when the condensers are rotated should be adjusted first to a maximum amount. If bending one is insufficient, start the next smallest one, and so on until peak response is attained.

3. Set the tuning dial now to 1,400 kc. and bend leaves (those still in mesh only) until correct maximum response and correct alignment are attained.

### Tracking Adjustment for Super-heterodyne Receivers

In a superheterodyne, the oscillator frequency is set above the signal frequency and must stay as nearly as possible the same number of kilocycles above the signal frequency for every setting of the tuning dial. The difference between the oscillator and signal frequencies, of course, is the intermediate frequency and, for example, if the dial is set to 1000 kc. for a receiver having an I.F. of 175 kc. the oscillator controlled by the same dial must be adjusted to function at 1,175 kc. (1000 plus 175 kc.). If the dial is set to 1,400 kc. subsequently the oscillator must function at 1,400 plus 175 or 1,575 kc. for proper reception.

When the other sections of the receiver are correctly adjusted, all tracking adjustments are made in the oscillator grid circuit. For this purpose there are three applications of a single basic circuit shown in Figs. 2A, 2B, and 2C.

Carefully note that in the oscillator grid circuits shown, the main "gang" tuning condenser is C1 having a shunt "gang" tuning condenser C2 of 1/5 to 1/8 its value and an adjustable condenser C3 in series with the combination, having a value usually somewhat greater than that of C1. This value must be so large—the amount of its variation need be so small—that often it is split into a fixed section C4 and a variable section C3 as in Fig. 2C.

Adjustment of C2 and C3 may be done correctly as follows:

1. Set receiver dial at 1,400 kc. and feed an oscillator signal or a station signal in the input (antenna and ground posts) and adjust condensers C2 for maximum output signal. This may be done with an output meter. The manner of connecting this device will vary with the particular receiver make and model.

2. Now set receiver dial to 600 kc. and adjust C3 for maximum. Condenser C2 should not be readjusted at 600 kc. because it will



No. 1179 Free-Point Test Set

Now you can carry a complete and compact laboratory with you and solve any testing problem... without having to guess what the trouble may be. This new Triplett portable laboratory, No. 1179, consists of three units: 1150 Oscillator, 1125 Volt-Ohm-Milliammeter, and the 1166 Free-Point Auxiliary Set Tester.

No. 1150 is a well designed, completely shielded oscillator. A switch permits generating either a stabilized modulated or unmodulated signal of constant level. Extremely accurate scale divisions cover fractional frequencies from 110 to 1600-K.C., on the individually hand-made chart. This method gives an extreme accuracy that cannot be secured in any other way.

No. 1125 contains a direct reading Ohmmeter, Output meter, A.C.-D.C. Voltmeter and Milliammeter. Complete with 16 different scale readings. All readings are controlled by a selector switch. It lends itself admirably to point to point continuity testing for set analysis and general testing.

The Free-Point Auxiliary Set Tester, No. 1166, is universal, flexible and designed to overcome obsolescence. Four sockets take care of all present day tubes.

YOUR JOBBER CAN SUPPLY YOU... at the dealer's net price of \$34.67

See him today.

THE TRIPLETT ELECTRICAL INSTRUMENT CO.

45 Main Street Bluffton, Ohio

### Send Coupon for Facts

Triplett Electrical Instrument Co.,  
45 Main Street, Bluffton, Ohio

Gentlemen:  
Send me catalog on Triplett Tester 1179... and complete line of radio servicing instruments.

Name .....

Street Address .....

City ..... State .....





# Train Now for New RADIO Opportunities



Get Into a Line Where There's Action—Every Day—And a Payday Every Week—You Be the Boss!

**Analyzer & Resistance Tester—Latest Design—YOURS Without Extra Cost**

Right now while hundreds are looking for work where there isn't any, the radio service field can use trained men. With the proper training and the necessary equipment, you can enter this field and make a comfortable living. We include with our course this modern set analyzer and trouble shooter without any extra charge. This piece of equipment has proved to be a valuable help to our members. After a brief period of training, you can take the set analyzer out on service calls and really compete with "old timers." We show you how to wire short-wave receivers—analyze and repair all types of radio sets—and many other profitable jobs can be yours. Teaching you this interesting work is our business and we have provided ourselves with every facility to help you learn quickly yet thoroughly. If you possess average intelligence and the desire to make real progress on your own merits, you will be interested.

## ACT NOW—MAIL COUPON

Start this very minute! Send for full details of our plan and free booklet that explains how easily you can now cash in on radio quickly. Don't put it off! Write today. **SEND NOW!**

RADIO TRAINING ASSN. of AMERICA  
Dept. RCR-4, 4513 Ravenswood Ave., Chicago, Ill.

Gentlemen: Send me details of your Enrollment Plan and information on how to learn to make real money in radio quick.

Name .....

Address .....

City..... State.....

## THE NEW Model E 36 TUBE TESTER

Read these excellent features which give complete details about the new Model 36 Tube Tester.

- (1) Direct Reading.
- (2) Mutual conductance test.
- (3) Line voltage regulation both Plate and Filament on separate A.C. meter.
- (4) No obsolescence due to new 36 point, 6 pole rotary switch—Provisions for new sockets.
- (5) Complete short test of all elements. Diode test-cathode leakage test.
- (6) Rapid and accurate.
- (7) Filament voltage range for all tubes.
- (8) Portable, handsome leatherette covered case.



DEALERS NET PRICE **\$87.50**

Sold on 10 day trial or money refunded. Circular on request.

**L & L ELECTRIC COMPANY**

Dept. 7-A

336 MADISON AVE. MEMPHIS, TENN.

## Get the finest RESISTORS SUPPRESSORS CONDENSERS

Servicemen, experimenter and manufacturer alike, throughout the world, rely upon Continental for quality and service unsurpassed. New catalogs show complete lines of resistors, auto-radio suppressors, and condensers.

Ask Your Jobber or Write

**CONTINENTAL CARBON Inc.**

12904 LORAIN AVE. CLEVELAND, OHIO

have practically no effect. The same may be said for readjustment of  $C_3$  at 1,400 kc.

3. If you do not obtain the correct response between 600 and 1,400 kc. the trimming adjustment must be repeated.

### Oscillator Feed-Back Adjustment

In Fig. 2, condenser C is for the purpose of regulating the oscillator. In some cases the oscillator tube will grow less and less efficient with use, finally stopping oscillation. When a new tube is replaced adjustment must be made according to its particular sensitivity. To adjust this condenser proceed as follows:

1. Tune the receiver dial to a station around 600 kc. and turn set screw of C counter-clockwise until the set goes "dead." Turn in a clockwise direction until station again comes in and add one or two additional turns. If the set operates for any setting of this capacity it should be adjusted at a minimum position. The volume control of the receiver should be full-on during adjustment.

### I.F. Stage Alignment

Each intermediate stage in a superheterodyne having tuning facilities must be adjusted for a definite frequency response. This is the intermediate frequency. From 2 to 8 adjustments may be necessary depending on the design. Procedure for correct adjustment follows:

1. Connect the output of an oscillator to the plate terminal of the 1st-detector socket (the tube being removed) and to ground. If the oscillator output has no series capacity, one should be used to avoid D.C. If the oscillator is modulated either an output meter or the speaker may be used for indicating response but if the oscillator is unmodulated a 2nd-detector plate meter is advised. A tuning meter provided where A.V.C. is used is suitable also, and if A.V.C. is used with no tuning indicator, a plate milliammeter should be used and tuned for minimum plate current.

2. Starting with the grid circuit of the 2nd-detector, turn the adjusting screw for maximum response, and proceed toward the 1st-detector. Both plate and grid circuit are usually tuned and require adjustment.

## COMBINATION AMPLIFIER-TUNER

(Continued from page 604)

connects the plate P2 of the second triode to the special push-pull input class A prime transformer, T2.

As the tuner volume control, R17, is provided with its own on-off switch, the phono-microphone preamplifier and the tuner may be operated simultaneously or independently from each other, permitting mixing and fading from one type of program to another, or permitting a radio program for instance to be used as a musical background for the microphone program.

A tone and microphone feed-back control, R18, is placed across the power amplifier and is therefore effective on both the radio and the phono-microphone amplifier. It is equipped with a master "ON" and "OFF" power switch. The three controls and switches thus constitute a very simple but complete and efficient P.A. control board.

## 10¢ A DAY BUYS A NEW REMINGTON PORTABLE TYPEWRITER Special 7-Day Free Trial Offer

Think of it! You can buy a new standard Remington Portable Typewriter for but 10c a day. Standard keyboard. Small and capital letters. Beautiful finish. Carrying case included free. Exceptional money-making opportunities. Write today. Say: Please tell me how I can get a new Remington Portable typewriter on your special 7-day free trial offer for but 10c a day.

Remington Rand Inc., Dept. RC-9, Buffalo, N. Y.



## Really Relax

After a busy day or a long motor trip, you crave the comforts that The American and The Annex afford. Good rooms with bath, circulating ice water, telephones and all modern conveniences. Beds that assure restful sleep. Here you can really relax when you visit St. Louis. Rates from \$1.50 single \$2 double



in ST. LOUIS

## SEXOLOGY

THE MAGAZINE OF SEX SCIENCE

SEXOLOGY, foremost educational sex magazine, is written in simple language and can be read by every member of the family. It is instructive, enlightening—not a risqué book—contains no jargon. Devoted to Science of Health Hygiene.

Contains 25 important articles on Sex Science, 68 pages, with attractive two-color cover. Here are a few of the more important articles: Editorial—Truth in Sex Literature; Chastity Belts (illustrated); Sex "Inversion"; Superstitions About Virginity; Frequency of Sex Diseases; Double Pregnancy in Double Womb (illustrated); Cure of Syphilis Slow; Sex Knowledge for Children; Abnormalities of Female Breast (illustrated); Venereal Disease Prevention (illustrated); Continuous Menstruations; All About Your Glands (illustrated); Giants Are Impotent; The Menopause; The Message of the Urine (illustrated); Sex and Pain; Questions and Answers; Scientific Sex Notes; Book Review.

Get a copy of SEXOLOGY on any newsstand, or, if your dealer cannot supply you, send 25c in stamps for a copy of the current issue. SEXOLOGY 25R West Broadway New York, N. Y.



### The Power Amplifier and Power Pack

The power amplifier consists of four 43 tubes grouped in push-pull parallel fashion. The relatively large bias voltage is obtained partially from the cathode resistor, R4, and partially from the speaker field current, which has to flow through the same resistor in order to complete its circuit. At this higher bias the tubes are operated in class A prime circuit, and it becomes imperative to employ a large bypass condenser (10 mf., 35 volts, C7) in order to obtain the maximum undistorted audio output power of 7½ W. The resultant tone and quality has seldom been attained before in A.C.-D.C. receivers, and is only equalled in performance by the very best console type.

The speaker field employed has a resistance of 4,000 ohms. This assures a minimum power consumption, as the current drawn is only 20 ma. Provision is made to handle two such speaker fields, as the rectifier tubes are being taxed only up to a part of their combined current handling capacity of 200 ma., D.C. or A.C. This permits the use of low-frequency and high-frequency type loud-speakers to obtain realistic performance.

If A.C. or magnetic type speakers are employed, no provision is required to close up the fields, the receiver remaining in an electrically balanced condition with a slight reduction of undistorted A.F. output power, a corresponding smaller load being consequently imposed upon the rectifier tubes.

The matching output transformer should have an output impedance from plate to plate of 2,000—2,000 ohms, or if two speakers are employed with their individual transformers the plate to plate impedance of each should be 4,000—4,000 ohms.

As the two 25Z5 rectifier tubes are of the slow-heater type, no strain is imposed upon the large capacity filter condensers C9, C10, which assures absolutely hum-free performance, although only half-wave rectification is employed on A.C. (such filtering would have been absolutely prohibitive at the high voltages commonly encountered in A.C. receivers of same power output). When operated on D.C., this filtering action entirely eliminates all line noises from the receiver and amplifier. As the power transformer and line voltage surges have been done away with in this system, the resulting danger of breakdown has been completely eliminated. The filter chokes Ch.1, Ch.2, should have 500 ohms resistance or less to prevent a voltage drop that would lower the voltages for the remaining tubes.

It might be well to mention here that successful home recordings may be made with this system not only of radio programs, but also of singing, speeches, or all other sounds fed through a microphone, due to the inherent high gain of the 3 stage A.F. amplifier.

#### List of Parts

- One Coast-to-Coast drilled chassis, 10 x 18 x 3 ins.;
- One 4 gang condenser, superheterodyne type, 350 mmf., C1, C2, C3, C4;
- One Remington filter choke, 200 ohms, 50 ma., 30 hy.;
- Two Remington filter chokes, 500 ohms, 30 ma., 30 hy., Ch.2, Ch.3;
- One Remington universal phono-microphone input transformer, type D-2329, T1;
- One Remington class A prime push-pull input transformer, type E-683, T2;
- Two Clarostat .5-meg. tapered potentiometers, R16, R18;
- One Clarostat 10,000 ohm tapered potentiometer with 1000 ohms minimum resistance, R17;
- One Lynch resistor, 10,000 ohms, 1 W., R1;
- One Lynch resistor, .1-meg., 1½ W., R2;
- Two Lynch resistors, 25,000 ohms, 1 W., R3, R10;
- One resistor, 200 ohms, 5 W., R4;
- One Lynch resistor, 1 meg., 1 W., R5;
- One Lynch resistor, 250 ohms, 1 W., R6;
- One Lynch resistor, 10,000 ohms, ½-W., R7;
- One Lynch resistor, .25-meg., 1 W., R8;
- Two Lynch resistors, .5-meg., 1 W., R9, R12;
- One Lynch resistor, 3,000 ohms, 1 W., R11;
- One resistor, 110 ohms, 10 W., R15;
- One resistor, 30 ohms, 3 W., R13;
- One resistor, 10 ohms, 1 W., R14;
- One band-pass antenna coil and shield, L1;
- One even-gain interstage R.F. coil, L2;
- One 175 kc. I.F. transformer and oscillator coil composite unit, with shield, 1FT1;

## You'll Praise This NEW TEN-WATTER



Compact, wire-wound, vitreous-enameled—a low-priced, efficient, moisture-proof ten-watter that will be welcomed wherever quality with economy is a factor.

Positive, low-resistance contacts through non-oxidizing Monel metal bands and lugs—plus pigtailed for convenience. Will withstand high temperature, give long usage and permanent resistance value.

Same type made in three sizes, three ratings and 67 resistance values.



Write Dept. RC-4 for FREE New General Catalog and Vest Pocket Volume Control Guide.

## HEADQUARTERS FOR PUBLIC ADDRESS AMPLIFIERS

BUY DIRECT from MANUFACTURER and SAVE BIG MONEY!

Official Public Address Amplifier Manual and Sound System Treatise  
Second Edition THE ONLY BOOK AVAILABLE OF ITS KIND! Just Released!

100 Loose-Leaf!  
Post Paid Available with a Valuable Supplement Service!

Contains 64 Pages, 8" by 10½". Over 150 diagrams, charts and illustrations.

Filled from cover to cover with real "meat"—no theories that are over your head—but full of practical "dope"—adequately illustrated, simply and clearly explained. Not only tells you WHY but shows you HOW to correctly install, test, operate, and maintain P.A. Systems. Written for Beginners, Servicemen, Dealers and Professional Sound Engineers.



Here is BIG VALUE Victor Push-Pull 245 Amplifier

Excellent For All Microphone, Phono-Pickup And Radio Tuner Amplification Applications. Diagrams show use of various modern tubes. Instantaneous Heater Amplifier (ideal for "Call Systems") employs 1-226, 2-245, 1-250; Standard Model uses 1-56, 2-245, 1-280. Equipped with an output push-pull transformer for 7-15 ohm voice coils, and a phono-input transformer etc. Furnishes D.C. Field current to a 2000 ohm 110 Volt D.C. Dynamic speaker. High gain characteristics, and use of two A.F. stages, assure enormous volume on "mike" and phono-pickup. Completely assembled kit; wiring diagrams furnished. 110 volt A.C., 60 cycle.

ASTOUNDING VALUE \$6.95 LESS TUBES \$1.69 SET OF TUBES \$1.95 MATCHED DYNAMIC SPEAKER \$1.95

COAST-TO-COAST-RADIO-CORP. 123 K WEST 17TH STREET, NEW YORK, N.Y.

- One 175 kc. I.F. transformer, closely coupled, 1FT2;
- One R.F. choke, 8.8 mhy., L5;
- Four Coast-to-Coast cartridge condensers, ½-mf., 200 V., C5, C16, C18, C23;
- One Polymet dry electrolytic condenser, 50 mf., 25 V., C6;
- One Polymet dry electrolytic condenser, 10 mf., 35 V., C7;
- Three Polymet mica condensers, .006 mf., C8, C13, C14;
- One Polymet dry electrolytic, 50 mf., 150 V., C9;
- One Polymet dry electrolytic, 2 x 16 mf., 175 V., C10a, C10b;
- One Polymet dry electrolytic, 4 mf., 175 V., C11;
- Two Coast-to-Coast cartridge condensers, ½-mf., 200 V., C12, C22;
- Four Coast-to-Coast cartridge condensers, 1/10-mf., 200 V., C15, C19, C17, C4;
- One Polymet mica condenser, 300 mmf., C20;
- One Polymet mica condenser, .002-mf., C21;
- One triple-post connector post for microphone; BP1-3;
- Two twin-post connector posts for phones, BP4-7;
- One frequency-calibrated tuning dial and pilot bulb;
- Miscellaneous hardware, sockets, knobs, wire, cable, 1 amp. fuse and fuse block, etc.



RADOLEK CO., 136 Canal Station, Chicago

I am a Dealer ; Serviceman

I operate from Shop or Store ; Home

I own the following Test Equipment.....

My training and experience is.....

Name.....

Address.....

City..... State.....

**RADOLEK · CHICAGO**



## ALL-WAVE AIR SCOUT

Only Set of Its Kind in the World

Designed by  
**H. G. CISIN**,  
Inventor of the  
**Universal A.C.**  
**D.C. Circuit**

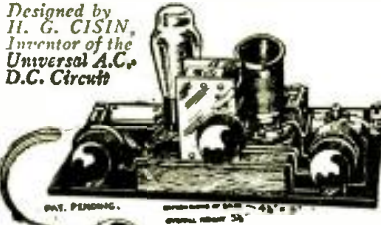

THIS powerful little set brings in all standard broadcast stations and also police calls, foreign stations, code and transatlantic phone conversations. Powered by inexpensive batteries. Available in KIT form. Patented terminal color coding feature eliminates need for wiring diagram. Red is connected to coil, black to black, etc., and set is ready to operate. Used by thousands of Boy Scouts. Scout John Stott of Sanford, Me., brought in England, Holland, Germany and South America on this set. Complete Kit with Tube, Earphone, Two Coils, nothing else to buy except batteries.

Not to Dealers and Servicemen  
Assembled, wired and ready POSTPAID  
to use—\$5.95 postpaid. List \$7.99

**SPECIAL OFFER: Valuable data on All-Wave Set sent free upon receipt of 10c to cover handling costs.**

ALLIED ENGINEERING INSTITUTE  
98 Park Place, Dept. R.C., New York, N. Y.

## YOU NEED

this inexpensive

# Knockabout Tester

designed by JACK GRAND

A most useful instrument when speed or rough use is essential.

The ranges are 0-5, 250 and 750 Volts, D. C.; 0-25 and 75 Mills. D. C.; 0-200,000 ohms.

All parts, including meter, drilled and engraved panel. Accurate shunt and multipliers.

**\$9.95**

COMPLETE including Blueprint

**VOLT - OHMMETER \$7.45**

Without Millamp. Range

COMPLETE—INCLUDING BLUEPRINT

Deposit Required—Send Money Order—Postage Extra

**SUN RADIO CO.**

227 FULTON ST. (cor. Greenwich St) New York City

## Why Pay More for Any Meter?

**BEDE Precision Electrical Instruments are Unsurpassed REGARDLESS OF PRICE!**



Quality and efficiency are the first consideration in all Beede Meters. In the D'Arsonval type of moving coil meters, improved design of the moving coil assembly permits maximum simplicity of construction, resulting in ruggedness, unusual accuracy and freedom from interference of dust and foreign matter. Beede meters are perfectly balanced in all positions and the moving systems are exceptionally well damped. Accuracy is guaranteed within 2 per cent. quality to lower costs. Beede meters represent improved quality and design, which in turn result in lower production costs. Beede prices are amazingly low.

Write for free descriptive circulars

Buy Beede meters from your distributor or order direct if he can not supply you.

**Beede Electrical Instrument Co.**  
48 West Broadway, Dept. RC New York City

## NEW — FREE!! SHORT WAVE CATALOG

of coils, condensers, converters, chokes, crystal holders, antenna kits and hundreds of other standard S.W. items that will last. LIST PRICES quoted throughout. Send for YOUR FREE copy today.

Insuline Corporation of America  
93-95 Park Place, Dept. CC-44 New York, N. Y.

## RADIO PICTORIAL

(Continued from page 584)

In number seven is shown a portable amateur station owned and operated by Mr. L. A. Morrow, Springfield, Ohio, and which can be on the air within fifteen minutes after reaching a location. Mr. Morrow plans to take this portable station to Florida and other states to make tests, but, with apologies to Joe Penner, we didn't know that this was permissible according to amateur rules and regulations.

## YOUR SERVICE OSCILLATOR

(Continued from page 587)

(11) Aligning short-wave receivers;  
(12) Checking A.F. circuits and apparatus;  
We will discuss each of these functions, under "average" conditions, in their numerical order, with reference to the service oscillator circuit shown in Fig. 1.

(1) To Align I.F. Circuits. (See "How to Align Radio Sets," in this issue.)

If the tuned circuits are badly out of alignment it may be necessary to use relatively high service oscillator output. The minimum output of this service oscillator is about 2 microvolts, but the maximum, across the attenuator, is 50,000 microvolts. If the latter figure is insufficient for initial alignment procedure, connection may be made to binding posts which provide an output of about 0.5-V. Crystal-calibrated frequencies of 600, 1000 and 1,400 kc. are provided.

(2) To Align I.F. Circuits for either "Flat Top" or "Peak" Resonance. The A.F. modulated I.F. output of the service oscillator is fed to the input of the I.F. amplifier section of the receiver (usually, the control-grid of the first-detector). For "flat top" resonance the service oscillator must first be set for one of the several crystal-calibrated frequencies of 150, 175, 202, and 456 kc. Then, set a "10 kc." dial provided on the service oscillator off-resonance a few kc., depending upon the number of tuned I.F. circuits and the desired degree of "flat top." After aligning one I.F. circuit at this frequency, the calibrated "10 kc." dial is moved to the next required frequency and the next I.F. circuit resonated for maximum output on the output meter. And so-on until the required number of alignments have been made.

For "peak" resonance the operation is much more simple. Just align the I.F. circuits for maximum output meter reading for the exact I.F. output of the service oscillator as specified for the individual receiver. (See "How to Align Radio Sets.")

(3) To Align Oscillator Circuits. (See "How to Align Radio Sets.")

(4) To Trim Oscillator Padding Condensers. (See "How to Align Radio Sets.")

(5) To Check Tube Efficiency. Apply a service oscillator frequency to the antenna and ground posts of the set and tune in the signal for maximum deflection of the output meter. Now, by replacing any tube in the set with another of the same type, the relative efficiency of either tube will be noted by a change in the reading of the output meter. Be careful to allow for differences in characteristics—especially, between tubes of the same type but of different manufacture.

(6) To Determine Overall Receiver Gain. It is not necessary for the Service Man to use a calibrated output meter, if he is accustomed to use the same instrument in his work, to obtain a good idea of the relative sensitivity of various receivers. The calibrated attenuator readings for various receivers, for a given deflection of the output meter, are noted, and these readings used as a basis for checking the sensitivity of other sets of equivalent type.

(7) To Test A.V.C. Circuit Operation. Connect the service oscillator to the input terminals of the radio set, and adjust the output, with the receiver volume control set at maximum, for a meter deflection of about one-half the optimum value. Now, substitute for the

## HERE'S A BOOK

# RADIO MEN WILL REFER TO MANY TIMES EACH DAY



A Valuable, All-round Radio Book!

HERE is one radio book that answers every conceivable question on interference. It contains 76 pages, 8½x11 inches, chock full with wiring diagrams, drawings and photographs showing where interference originates—how it is distributed, and how to eliminate it. This is a wealth of information needed by every radio listener, dealer and Service Man.

Send 50 cents in stamps or check for this book

**RADIO-CRAFT MAGAZINE**  
96-98 Park Place, New York, N. Y.

## CLASSIFIED ADVERTISEMENTS

Advertisements in this section are inserted at the cost of twelve cents per word for each insertion—name, initials and address each count as one word. Cash should accompany all classified advertisements, unless placed by a recognized advertising agency. No less than ten words are accepted. Advertising for the May, 1934, issue should be received not later than March 5th.

### A.C. GENERATORS

TEN Practical and inexpensive changes converting Dodge 12-V, Ford T. A., Chevrolet Delco 6-V generators into 100-500 watt capacity A.C. generators, or into 32-110-V. D.C. motor or generator. Dodge is 500-W self-excited. All in one book illustrated with complete simplified instructions and drawings for only \$1. Auto-power, 410 S. Hoyne Ave., Chicago.

### MISCELLANEOUS

"ESCO" Gasoline Driven Electric Generating Plant: 110 volts A.C. 300 watts. Urgent:—Granger, 12, Frederick Terrace, WISBECH, CAMBS, ENGLAND.

### RADIO

DO You want—anything built for you? We design or construct any radio or electrical apparatus to your satisfaction. Equipment Builders Co., Dept. 3G, 945 East 163rd Street, New York City.

### SONGWRITERS

SONGWRITERS! Poems, melodies. Amazing opportunity. Hibbler, D153, 2104 Keystone, Chicago.



# Increase YOUR SERVICING BUSINESS 25%

If you are overlooking servicing auto radios, then you're missing a great deal of business. The auto-radio business had its greatest boom this past summer and thousands of sets were sold. By this time many of these same sets require servicing and with hundreds of them right in your own community, you can build up a good auto-radio servicing business. In a short time you can easily add 25% or more to your regular servicing business.

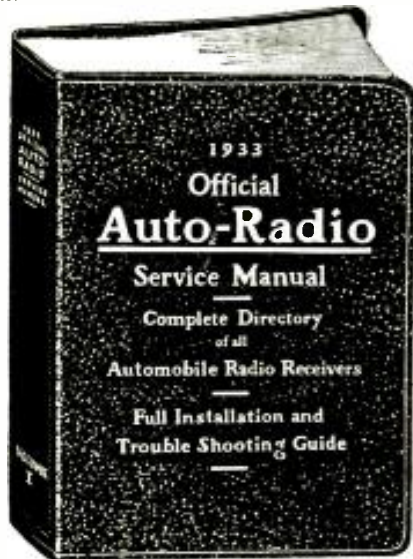

**\$2.50** A Copy

Every man connected in any way with the booming auto-radio business will want a copy of this book immediately. It is devoted exclusively to auto-radio service "dope" in complete, understandable form. The OFFICIAL AUTO-RADIO SERVICE MANUAL contains schematic diagrams, chassis layouts, mounting instructions, and trouble shooting hints on all 1933 and many older model auto-radio receivers. This Manual contains a "gold-mine" of information.

### List of Sets Covered in the Manual

Atwater Kent Mfr. Co.	Chas. Hoodwin Company
Aurocrat Radio Company	Montgomery Ward & Co.
Carter Genemotor Corp.	National Co., Inc.
Chevrolet Motor Company	Philco Radio & Tel. Corp.
Crosley Radio Corp.	Pierce-Alro, Inc.
Delco Appliance Corp.	Premier Electric Co.
Emerson Electric Mfg. Co.	RA-Victor Co., Inc.
Federated Purchaser, Inc.	Sentinel Radio Corp.
Fada Radio & Elec. Corp.	Sparks-Wilmington Corp.
Ford-Majestic	Stewart Radio & Tel. Corp.
Franklin Radio Corp.	United Amer. Bosch Corp.
Galvin Mfg. Corp.	United Motors Service
General Electric Co.	U. S. Radio & Tel. Corp.
General Motors Corp.	Wells-Gardner Company
Grisby-Grunow Co.	Zenith Radio Corp.

Over 200 Pages  
Over 500 Illustrations  
9x12 Inches  
Flexible, Loose-Leaf Cover

Mail This Coupon Today!

GERNSBACK PUBLICATIONS, Inc. RC434  
96-98 Park Place, New York, N. Y.

Enclosed you will find my remittance of \$2.50 for which please send me One Copy of the 1933 OFFICIAL AUTO-RADIO SERVICE MANUAL. (Send remittance in check or money order. Register letter if it contains cash or currency. WE PAY POSTAGE.

Name .....

Address .....

City ..... State .....

A.V.C. tube another of equivalent type. A reduction in the reading of the output meter indicates that the first tube was defective, and that the second tube is more suitable in the A.V.C. circuit.

(8) To Make Stage Analyses. By applying the output of the service oscillator to circuits preceding those of the output, and noting the response on the output meter, receiver faults may be readily localized. (RADIO-CRAFT, December, 1933, pg. 348.) Thus, open- and short-circuits in the wiring or apparatus may be located in minimum time.

(9) To Check Overall Receiver Selectivity. The "10 kc." dial makes it convenient to run a test of the overall selectivity of a given radio set. It is best to plot on graph paper the readings for various settings of the "10 kc." dial, on either side of resonance, with the service oscillator output feeding the antenna and ground posts of the set. Use the left-hand, vertical column for the meter readings, and the base line for "kc. off resonance."

(10) To Neutralize Receivers. (See "How to Align Radio Sets.")

(11) To Align Short-Wave Receivers. Frequencies other than the fundamental frequencies previously mentioned are available, as harmonics of these fundamentals, for aligning the circuits of modern short- and all-wave receivers. A sensitive receiver ordinarily is capable of receiving the 20th harmonic of the 1000 kc. fundamental of the service oscillator; the "10 kc." dial permits the fundamental to be shifted, in 1 kc. steps, 10 kc. either side of this value. The harmonics of the 1000 kc. frequency are conveniently 1 megacycle apart, so that it is handy to start testing and calibrating at, say, 2,000 kc., on the receiver. With this point located, the 3,000 kc. calibration is located from the 3d harmonic of the 1000 kc. test note. To confirm this point, the frequency-selector switch may be adjusted for 1,500 kc., to determine whether the 2nd harmonic of this note is heard at exactly the same point on the receiver dial. The frequency-selector switch is then re-set at 1000 kc., and the 4,000 and 5,000 kc. points on the receiver dial located. At 6,000 kc. the actual frequency can again be definitely established by using both the 1000 kc. and 1,500 kc. service oscillator frequencies to be certain of the actual harmonic that is being used. This seemingly long-winded, but actually simple procedure eliminates the possibility of mistaking "ghost" and other spurious frequencies for those of the calibrating instrument.

(12) To Check A.F. Circuits and Apparatus. Microphonic tubes, cabinet resonance, and other defects in the audio system of the radio receiver may be located by connecting the full output of the service oscillator to the control-grid of the audio tubes, whereupon the 400 cycle note of the service oscillator modulator tube will be heard in the reproducer.

Since many of the tests described above depend for their efficiency upon the accuracy of the service oscillator, it may be well to point out that the particular instrument illustrated has a frequency variation of less than 0.2-ke. for a change in line voltage of 90 to 120 V. Electron coupling of the oscillator circuits is used to insure further stability. The method of coupling the oscillator and modulator circuits eliminates "frequency modulation," which would cause broadness and instability in the output frequencies. The R.F. output is prevented by a system of choke coils from feeding via the light lines into the receiver under test.

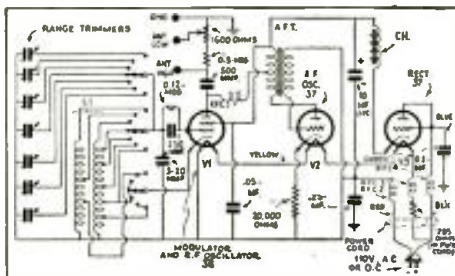

Fig. 1  
Representative, modern service oscillator.

## Behind the POLYMET Trade Mark



Many leading manufacturers, in both the radio and electrical industries, have come to recognize in POLYMET Products that quality, so essential to dependability. THEIR ENGINEERS DO NOT GUESS—THEY KNOW.

The successful service man does not guess, he knows that the use of POLYMET Products in replacement work is his guarantee of satisfaction.

### Polymet Condensers

ELECTROLYTIC  
Wet and Dry Types  
PAPER  
Pe-Tite Tubular  
Hi-Volt in Cans  
Uncased Sections  
Oil Condensers (Transmitting and Industrial uses)

MICA  
All Types—Midget sizes with lugs or leads.  
Large type for industrial uses.

TRANSFORMERS  
WIRE WOUND RESISTORS

Write for new 1934 catalog now in preparation  
**POLYMET MFG. CORP.**  
833-R East 134th St. New York, N. Y.

## New, Improved Radio Service Oscillator

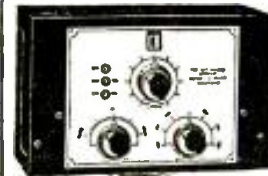

Designed by  
Kendall Clough  
Clough-Bregle  
Model OA

### The Most Useful Service Instrument

Every serviceman needs this remarkable new service instrument that is invaluable for performing over fifty everyday service tests and adjustments, including r.f. and i.f. alignment, selectivity, receiving output, A.V.C. action, and audio system tests.

Completely operated from any A.C. or D.C. line. Provides every r.f. output frequency needed for adjustment or intermediate, broadcast, and short-wave circuits. No calibration curves to confuse or cause inaccuracies. Every fundamental frequency adjusted and permanently sealed at zero-beat against quartz crystal oscillators. Write for descriptive literature and free frequency chart that every serviceman needs.

### Write Today for the New C-B Catalog

Just off the press! Contains complete description of the new C-B Statchecker for modernizing your set analyzer; the C-B Unimeters that make every voltage, current, resistance, and output measurement. Also the new low-price STATICLEAR Balanced Antenna System.

The Clough - Bregle Co.  
1134 W. Austin Ave., Chicago, Ill.

Send me your new 1934 Test Equipment Catalog.

NAME .....

ADDRESS .....

CITY ..... STATE .....

**SERVICEMEN!**  
THE MOST COMPLETE LINE OF CONDENSERS  
AND RESISTORS FOR EVERY RADIO USE  
Write for our new 10-page Catalog today—free of charge

**AEROVOX**  
CORPORATION

76 Washington Street Brooklyn, N. Y.

**STUDY UP ON THEATRE Sound Devices**

World-Famous 3 Volume, "Sound Projection," "Servicing Projection" and "Simplified Servicing of Sound Equipment," Original Value, \$15.00. Set of 3, \$2.95; Individually \$1.19 each.

World's Largest Theatre Supply House

**S. O. S. CORPORATION**

1600 BROADWAY NEW YORK, N. Y.

**SERVICE MEN!**  
Increase Your Earnings  
Up to \$30-\$50 Weekly  
Our Proven, Tested Plan Tells How.  
Write for Complete Details TODAY!  
INSULINE CORP. OF AMERICA,  
23-25 Park Place, Dept. C-44 New York, N. Y.

**BACK ISSUES OF RADIO-CRAFT**

which you might need to complete your files, can still be had at the price of 25c per copy. Send us your requirements, together with your remittance in check or money order.

**RADIO-CRAFT**

96-98 Park Place New York, N. Y.

**READER'S DEPARTMENT**

(Continued from page 605)

was submitted at the last meeting should be adopted at once. The sooner the better, and when adopted it should be enforced rigidly. Quack physicians are soon ostracized from their profession; shyster attorneys are likewise considered rabble. Therefore, I believe that the "soi disant" technician should be eliminated from the ranks of the professional technician until such a time as he has served his apprenticeship and proven to a board of examiners his technical qualifications beyond a doubt. By eliminating the radio quack and shyster we will, to my belief, eliminate the cut-price and cut-throat artist from our chosen profession.

Just as physicians, surgeons and attorneys consult their superiors and colleagues when they encounter a puzzling diagnosis or legal matter the radio technician should also consult his superiors and go into a huddle on some perplexing technical problem.

One of the most important points in maintaining the professional attitude so important to the radio servicing is to dress like gentlemen, not grease monkeys, wearing dirty chambray shirts, smeared full of grease as seen at a recent meeting of radio technicians. No wonder the public is against paying \$1.00 for the service call to Service Men of this type. Put on canvas gloves to avoid marking console cabinets, spread papers under the tool kit, brush out the chassis on additional paper, wipe dust off tubes, touch up scratches on cabinets, etc.

M. MICKELSON,  
3336 16th Ave., South,  
Minneapolis, Minn.

Mr. Mickelson is perfectly right. Too many Service Men neglect the important point of appearance when attending to their service calls. Radio servicing is, after all, selling just as every other occupation is a

selling job. It does not make any difference whether you sell service, material or whether you sell your services to a "boss" or a group of customers—it is still selling. And every good salesman appreciates the importance of appearance. The point cannot be stressed too highly.

**TUBE TESTER**

(Continued from page 602)

On the panel are inscribed all the instructions for operation when testing only the current types of tubes.

Four flexible cords, P, P, G, K (see diagram, Fig. 1), with miniature plugs, permit every possible inter-connection required of the various tube elements. Connections are made by inserting these plugs into the jacks shown: J1, J2, J3, J4, J5, J6, J7, J8.

Transformer T1 has a 5 V. primary, which is energized by the 61A socket filament supply in the old tester. A rear view of the panel illustrating the mounting and wiring of the unit is shown in Fig. C. The super-multiadapter may be quickly and easily constructed by using the material specified and by following the wiring diagram of Fig. 1. Resistor R1 is connected in the plate circuit by pressing switch Sw.1, and serves to reduce the plate current to a safe value. This is only done when the meter on the old tester goes off scale, when testing some of the new, high-plate-current tubes.

Calibration of the old tester for the new tubes can easily be accomplished by testing a good, new tube (one for each type) and marking down its reading for grid-shift test, or by noting the position of the compensator, rheostat, or potentiometer of other types.

For 2.5, 3.3, 5 and 7.5V., set Sw.2 at x and supply from tester, in testing the tubes shown in Table I. The asterisk (\*) indicates special short-wave tubes.

**Another Big Boom In Radio . . .**

**PUBLIC ADDRESS INSTALLATION**

**It's a Money-Making Field**

Here is a new edition to the RADIO-CRAFT Library Series—it's a book which shows radio men how to really make extra money in a fast-growing field, allied to radio. In public address work unlimited opportunities arise—it's practically a rejuvenation in radio. Know the facts about public address equipment and get your share of business. Get a copy of **PUBLIC ADDRESS INSTALLATION AND SERVICING**, by J. T. Bernsley—it covers modern methods of servicing and installing public address equipment.

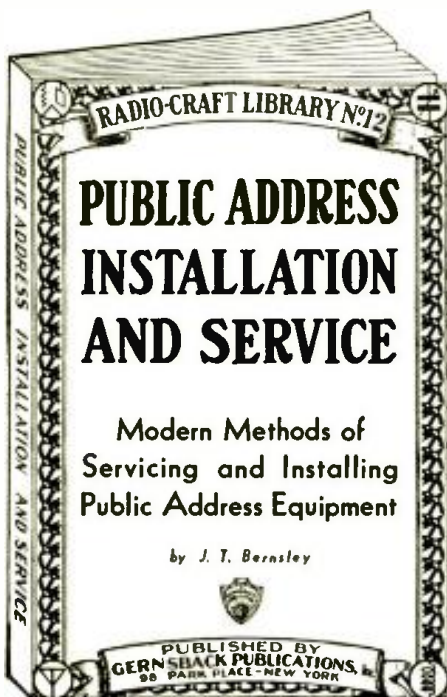

**A BRIEF SUMMARY OF THE CONTENTS**

**AUDIO AMPLIFIER FUNDAMENTALS—**  
Introduction; Discussion on types of amplification—transformer coupling, resistance coupling, impedance coupling, push-pull and miscellaneous; New Terms and Theory—Class A amplification, Class B amplification, Voltage amplifier; Power amplification; Pre-amplifier, Carbon microphone, Condenser microphone, Ribbon or velocity microphone; Power Supply Requirements—For Class A, For Class B.  
**PUBLIC ADDRESS AMPLIFIERS—**  
Standard Installation—4½ watt amplifier, 7 watt amplifier, 10 watt amplifier, 15 watt amplifier, 20 watt amplifier, 30 watt amplifier, 40 watt amplifier, 50 watt amplifier; Special Installation—Portable—6 volt operated amplifier; Mobile-use amplifier, 26 watt (Radio-Craft), AC-DC—and 6 volt amplifier, Pre-amplifier (1 stage, 2 stage, 3 stage).

**INSTALLATION INSTRUCTION—**  
Analyzing Requirements; Best methods for installing—Indoor, outdoor; Methods for minimizing "howl" or audio oscillation present after installing; Speaker Installation (horn type, baffie type); General Instructions and Hints.

**ACOUSTICS—**  
How to survey and analyze an auditorium for reverberation time—with formulas, and correct method for treatment; chart with absorption coefficients of standard treating material.

**SERVICING—FORMULAS—**  
Amplifiers; Power Supply devices; Speakers; Microphones (carbon, condenser, ribbon or velocity); Formulas—decibel, meaning and use, calculation overall audio gain, distortion in amplifier; Conclusion.

**64 PAGES — 6 x 9 INCHES — OVER 50 ILLUSTRATIONS**

This book can be bought in combination with other books in this series—see page 580.

**GERNSBACK PUBLICATIONS, Inc. 96-98 Park Place, New York, N. Y.**

**GERNSBACK PUBLICATIONS, Inc., 96-98 Park Place, New York, N. Y.**  
Gentlemen: Enclosed you will find 50 cents, stamps, checks or money order accepted, for which send no postage prepaid, One Copy of the new book, **PUBLIC ADDRESS INSTALLATION AND SERVICING**.

Name .....

Address .....

City .....

State .....

RC-434



● Index to Advertisers ●

<b>A</b>	
Aerovox Corporation .....	634
Allen Mfg. Co. ....	626
Allied Engineering Institute .....	632
Allied Radio Corp. ....	618
American Hotel .....	630
Automator Laboratories, Inc. ....	628
<b>B</b>	
Beebe Elec. Instrument Co. ....	632
Bud Speaker Company .....	635
<b>C</b>	
Capitol Radio Research Laboratories. ....	624
Central Radio Laboratories .....	612
Clarostat Mfg. Company .....	616
Classified Section .....	632
Clough-Bronfle Company .....	633
Coast-to-Coast Radio Corp. ....	626, 631
Continental Carbon, Inc. ....	630
Coyne Electrical School .....	577
<b>D</b>	
Deutschmann Corp., Tobe .....	626
<b>E</b>	
Electrad, Inc. ....	681
<b>F</b>	
Fordson Radio Mfg. Co. ....	616
<b>G</b>	
General Transformer Company .....	621
Greenpark Company .....	638
<b>H</b>	
Hammarlund Mfg. Company .....	612
Harrison Radio Company .....	617
Hygrade-Sylvania Corp. ....	627
<b>I</b>	
Insuline Corp. of America .....	632, 634
<b>L</b>	
L. & L. Electric Company .....	630
Leeds Radio Company .....	628
Leotone Radio Company .....	624
Lynch Mfg. Company .....	622
<b>Mc</b>	
McGraw-Hill Book Company .....	622
<b>M</b>	
Midwest Radio Corp. ....	Back cover
<b>N</b>	
National Radio Institute .....	579
National Union Radio Corp. ....	Inside back cover
<b>P</b>	
Polymet Mfg. Company .....	633
Popular Book Corp. ....	629
Precision Resistor Company .....	655
<b>R</b>	
Radio & Amplifier Labs. ....	628
Radio Circular Company .....	638
Radio City Products Company .....	635
Radio Trading Company .....	610
Radio Training Association .....	630
Radolek Company .....	631
RCA Institutes, Inc. ....	612
RCA Radiotron Co., Inc. ....	613
Readrite Meter Works .....	625
Remington Rand, Inc. ....	617, 630
<b>S</b>	
S. O. S. Corp. ....	634
Sexology .....	630
Shalleross Mfg. Co. ....	620
Shure Brothers Company .....	618
Silver, Inc., McMurdo .....	619
Smith & Co., Johnson .....	636
States Radio Laboratories .....	626
Stewart-Warner Corp. ....	628
Sun Radio Company .....	632
Supreme Instruments Corp. ....	615
<b>T</b>	
Triplett Electrical Instr. Corp. ....	629
Try-Mo Radio Corp. ....	624
<b>U</b>	
United Sound Engineering Co. ....	624
Universal Microphone Company .....	626
<b>W</b>	
Webster Company .....	620
Wellworth Trading Company .....	639
Westinghouse Elec. & Mfg. Co. ....	617
Weston Electrical Instr. Corp. ....	623
Wholesale Radio Service Company .....	614

(While every precaution is taken to insure accuracy, we cannot guarantee against the possibility of an occasional change or omission in the preparation of this Index.)

List of Parts

- One 5½ x 9 in. super-multidapter panel, drilled and engraved, with mounted tip-jacks;
- One leatherette-covered case, with hole and bushing;
- One knob, with indicator;
- One 4 prong 2 piece speaker plug;
- One 4 wire cable, 18 Ins. long;
- Five Na-Aid molded sockets (V1 to V5), 4, 5, 6, 7, 7 prong-large;
- One molded control-grid cap and cord;
- One Dependable transformer, T1;
- One momentary S.P.S.T. switch, Sw.1;
- One Dependable 9 point filament selector switch, Sw.2;
- One I.R.C. resistor, 5,000 ohms, R1;
- One Dependable jack-strip, 8 jacks, J1 to J8;
- Four miniature plugs, P, P, G, K.

TABLE I

Tube Type	Filament Volts	Connect Plugs		
		P to	G to	K to
1	6.3	1	—	3
5	6.3	1-8	3	—
*10	7.5	Cap	1	—
18	11.0	2	5	8
19	2.0	1-8	4	—
*20	2.5	2-5	—	8
*22	6.3	2-5	—	8
25	2.5	2	5	8
29	2.5	2-5	—	8
*30-S	2.0	Cap	1	—
33	2.0	1-8	3	—
41	6.3	2	5	8
42	6.3	2	5	8
43	25.0	2	5	8
16	2.5	1-8	3	—
47	2.5	1-8	3	—
48	30.0	2	5	8
19	2.0	1-8	3	—
52	6.3	1-8	3	—
53	2.5	1-8	3	5
55	2.5	2-5	—	8
57	2.5	2-5	—	8
58	2.5	2-5	—	8
59	2.5	2-5	7	8
68	6.3	2	5	8
69	6.3	2-5	—	8
70	6.3	2-5	—	8
75	6.3	2-5	—	8
77	6.3	2-5	—	8
78	6.3	2-5	—	8
79	6.3	1-8	3	5
80	5.0	1	—	—
2nd Plate		3	—	—
82	2.5	1	—	—
2nd Plate		3	—	—
83	5.0	1	—	—
2nd Plate		3	—	—
84	6.3	1	—	8
2nd Plate		3	—	8
85	6.3	2-5	—	8
89	6.3	2-5	—	8
90	2.5	1	5	—
92	6.3	1	5	—
96	10.0	1	—	—
98	6.3	1	—	—
2nd Plate		3	—	—
257	5.0	1-8	3	—
865	2.5	Cap	—	—
1A6	2.0	2-8	5	—
2A5	2.5	2	5	—
2A6	2.5	1	5	—
2A7	2.5	2	6	—
6A4	6.3	1-8	3	—
6A7	6.3	2	6	—
12A5	6.3	2	7	—
2B6	2.5	2	7	—
2B7	2.5	2	6	—
6B7	6.3	2	6	—
6C6	6.3	2-5	—	—
6D6	6.3	2-5	—	—
6D7	6.3	2	6	—
6E7	6.3	2	6	—
2F7	2.5	2-7	5	—
6F7	6.3	2-7	5	—
6Y5	6.3	3	—	—
2nd Plate		8	—	—
5Z3	5.0	1	—	—
2nd Plate		3	—	—
6Z3	6.3	1	—	3
6Z4	6.3	1	—	3
2nd Plate		3	—	—
6Z5	6.3	1	—	3
2nd Plate		5	—	—
12Z3	12.6	1	—	3
12Z5	12.6	1	—	4
2nd Plate		8	—	—
25Z3	25.0	1	—	3
25Z5	25.0	1	—	4
2nd Plate		8	—	—
AD	6.3	1	—	4
2nd Plate		3	—	—
AE	12.6	2	5	8
GA	5	1-8	3	—
LA	6.3	1-8	3	—
PA	6.3	2	5	8
PZ	2.5	1-8	3	—
PZB	2.5	2	5	8
HZ50	12.6	1	—	3
IV	6.3	1	—	3



Modernize  
Your  
Out-of-Date  
Tube  
Tester  
with the

Model 205 Super Multidapter

YOU'LL obsolete Counter Model or Portable Tube-Tester undoubtedly was a costly investment but the Super Multidapter again brings it up-to-the-minute, eliminating the necessity of waiting a valuable meter or expensive high-grade instrument.

Individual adapters are not required since the Super Multidapter supplies all filament voltages not available on your present tube tester. Provides for testing every tube on the market and new tubes coming later—it is extremely flexible.

This remarkable new device is extremely simple to use. The entire panel is self-explanatory. No charts or direction sheets are necessary. Panel is beautifully etched. Instrument is provided with an attractive, sturdy, leatherette case, 7" x 9½" x 3¼". Weighs only 2½ lbs.

If your distributor cannot supply you, order direct. Write for free circulars describing all radio test equipment.

**RADIO CITY PRODUCTS CO.**  
45 WEST BROADWAY Dept. RC NEW YORK, N. Y.

Knock  
Down Kit  
**\$5.95**  
Completely  
Wired and  
Assembled  
**\$7.50**  
NET TO  
DEALERS  
AND SER-  
VICEMEN

*Dependable Sensational Performance!*

## BUD

**Laboratory-Built  
P. A. Equipment**

**5  
DAYS  
FREE  
Trial**

**ELECTRO-DYNAMIC UNITS  
DOUBLE BUTTON CARBON  
MICROPHONES - 4 & 6 FT.  
ALL ALUMINUM TRUMPETS  
FIELD EXCITERS - AIR COLUMN  
HORNS - LOW AND HIGH  
FREQUENCY UNITS FOR WIDE  
RANGE THEATRE USE**

*Try BUD Sound  
Equipment  
For Five Days  
Absolutely Free!*

We invite careful, critical inspection of our entire line of BUD laboratory built sound equipment. We suggest that you conduct your own comparative test. We CHALLENGE you to duplicate BUD performance and BUD dependability at ANY PRICE. Write today for descriptive literature and prices and details of our FREE FIVE DAY TRIAL OFFER.

**BUD SPEAKER CO.**  
1105 Jackson Street  
TOLEDO, OHIO, U.S.A.

## Try this FORMULA

WHEN you design or build that new Set Analyzer, Decade Box, Bridge, Ohmmeter or High Resistance Voltmeter why not try this FORMULA:  
Q + A + MD = PwWR

I.C. = PwWR  
When Q equals QUALITY and A equals ACCURACY  
MD equals MODERN DESIGN and I.C. equals LOW  
COST and LAST COST then PwWR is always PRECISE.  
PRECISION WIRE WOUND RESISTORS.  
RESISTANCE RANGE: .25 Ohm to 1 Megohm

**TYPE "F"**  
Normal Rating  
Maximum 1 Watt  
Maximum Length 1"  
Maximum Diameter ½"  
Length of Leads 1¼"  
Furnished with No. 18 Tinned Copper Leads.

**TYPE "D"**  
Normal Rating  
Maximum ½ Watt  
Maximum Length ¾"  
Maximum Diameter ¼"  
Length of Leads 1¼"  
Furnished with No. 18 Tinned Copper Leads.

*Free Booklets and Price List  
Precision Custom Built Wire Wound  
Resistors, Mfg. by*

**PRECISION RESISTOR CO.**  
334 Badger Ave. Newark, N. J.



# Blank Cartridge Pistol

REVOLVER STYLE

.22 CAL.  
MADE IN 3 SIZES



25c  
50c  
\$1.00

Three new models now out 25c, 50c and \$1.00. Well made and effective. Modelled on pattern of latest type of Revolver. Appearance alone enough to scare a burglar. Takes 22 Cal. Blank Cartridges obtainable everywhere. Great protection against burglars, tramps, dogs. Have it lying around without the danger attached to other revolvers. Fine for 4th July, New Years, for stage work, starting pistol, etc. **SMALL SIZE 4 in. long 25c. MEDIUM SIZE 5 in. long 50c. LARGE SIZE 6 in. long \$1.00. BLANK CARTRIDGES 50c per 100. HOLSTER (Cowboy type) 50c. Shipped by Express only not prepaid. 710 page catalog of other pistols, sporting goods, etc. 10c**

## BOYS! THROW YOUR VOICE

Into a trunk, under the bed or anywhere. Lots of fun fooling teacher, policeman or friends.

**THE VENTRILO**  
a little instrument, fits in the mouth out of sight, used with above for Bird Calls, etc. Anyone can use it. Never fails. A 16-page course on Ventriloquism together with the Ventrilo. All for 10c postpaid.

## Subscribe to our Monthly Magazine Fun, Magic and Mystery

We also publish a monthly magazine of **FUN, MAGIC AND MYSTERY**. Each issue contains a big collection of parlor magic, tricks with cards, fortune-telling, funny readings, amusing experiments, money-making secrets, jokes, riddles, conundrums, parlor amusements, puzzles, problems, science, mechanics, etc. In addition it will list all the latest novelties, tricks, puzzles, etc. Because it is really a magazine and catalog combined, we have fixed the subscription price at **ONLY 10c** per year, or 3 years for 25c. This as you readily see does not even cover our mailing expenses, let alone the cost of getting up the magazine. Try this magazine for one year.

## Novelty French Photo Ring

Here is a very great novelty in Rings, that is selling in thousands. It is a nicely made ring, finished in million platinum, and set with a large imitation diamond. It looks just like an ordinary ring, but in the shank of the ring is a small microscopic picture almost invisible to the naked eye, yet is magnified to an almost incredible degree and with astonishing clearness. There is quite an assortment of pictures that should suit all tastes. Some are pictures of bathing girl beauties, pretty French Actresses, etc., others are views of places of interest in France, Panama Canal and elsewhere; others show the Lord's Prayer in type, every word of which can be read by persons with normal eyesight. They are interesting without being in any way objectionable. **PRICE 25c. 3 for 65c, or \$2.25 per doz. postpaid. 710 page Catalog 10c.**



## MAKE YOUR OWN RADIO RECEIVING SET

Enjoy the concerts, baseball games, market reports, latest news, etc. This copy-righted book "222 RADIO SETS" shows how to make your own receiving set. Includes plans for portable Radio Sets, the materials for which can be purchased for a mere trifle. Also tells how to build a short-wave receiver for listening in foreign stations, police calls, ships at sea, etc. **ONLY 15c. postpaid.**

## SILENT DEFENDER

Used by police officers, detectives, sheriffs, night watchmen and others as a means of self-protection. Very effective. Easily fits the hand, the fingers being grasped in the four holes. Very useful in an emergency. Made of aluminum they are very light, weighing less than 3 ounces. Handy pocket, always ready for instant use. **PRICE 25c each, 2 for 45c postpaid.**

## BIG ENTERTAINER

180 Jokes and Riddles, 34 Magic Tricks, 54 Parlor Games, 73 Toasts, 15 Tricks with Cards, 50 Money-making Secrets, 10 Funny Readings, 3 Monologues, 21 Puzzles and Problems, 5 Comic Recitations, Cut-outs for Checkers and Chess, Dominoes, Fox and Geese, 9 Men Morris, Spanish Prison Puzzle, Game of Anagrams, etc. **All for 15c postpaid.**

## WONDERFUL X-RAY TUBE

A wonderful little instrument producing optical illusions both surprising and startling. With it you can see what is apparently the bones of your fingers, the lead in a lead pencil, the interior opening in a pipe stem, and many other similar illusions. **Price 10c, 3 for 25c.**

## HOW TO WIN AT POKER

Written by a card sharper. Tells how to win at draw poker. Explains different varieties of poker such as Straight Poker, Stud Poker, Five Card Draw, Hold'em, The Freeze-out, The Widow's Back, etc. Explains the methods used by card sharpeners and professional gamblers. This book contains a vast amount of information and may save you from being floored by crooked players and gamblers. **PRICE 10c postpaid. 710 page Novelty Catalog 10c**

## THE FAN DANCE

Hit of the Chicago Worlds Fair. Who will forget the famous FAN DANCE episode of the Century of Progress Exposition in Chicago. Here it is humorously, clearly, presented in vest pocket form. You flip the pages and **HOTSY TOTS** comes to life and whirls through her dance... provoking, not a sly smile, but a wholesome laugh from all. No end of fun at amusement. Spicy, piquant entertainment for all. Pocket size, 2 x 3 inches. **Price 10c ppp. 710 page Novelty Catalog 10c**

## Fortune Telling By Cards

Book shows how to tell fortunes with cards, dice, dominoes, crystal, etc. Tells the meaning and significance of every card. Several different methods explained and fully illustrated. Crammed full from cover to cover with complete information on fortune-telling. **PRICE 10c postpaid. Stamps accepted.**

## Good Luck RING

Very striking, quaint and common. Engraved (gunmetal finish); skull and crossbones design; try by hand! Here it is a imitation rubies or emeralds sparkle out of the eyes, each ring good luck to the wearer. **PRICE 25c Postpaid**

## HOW TO PITCH

Pitch the Fakel-a-very, Spitter, Knuckler, Smoker, Ball, etc. Lessons by leading Big League Pitchers. Illustrated and described with 56 pictures. **POSTPAID 25c**

## JAPANESE ROSE BUSHES

The Wonder of the World. Japanese Rose Bushes bloom all the year round. Just think of it. Six weeks after planting the seed, the plants will be in full bloom. It may not seem possible, but we positively guarantee it to be so. They will bloom every ten weeks, Summer or Winter, and when three years old the bush will bear masses of roses, bearing from five hundred to a thousand roses on each bush. The flowers are in three shades—white, pink, and crimson. The plants will do well both in and out doors. We guarantee at least three bushes to grow from each packet of seed. **Price, 10c packet, 3 pkts. for 25c postpaid.**

## Chinese Fragrant Tree Fern

Just introduced; noted for its rapid growth. An exceptionally pretty ornamental plant. Foliage is rich dark green. Forms grand pyramidal bushes about 6 feet high. Branches very desirable for decorative purposes, wreaths, etc. **Seeds 15c pkt. 3 for 40c.**

## Weather Plant

NATURE'S WEATHER PROPHECY. By mysterious changes that take place, this remarkable plant accurately forecasts the weather many hours in advance. Will grow anywhere all the year around. An interesting house plant. Bears large, fragrant, pink, buttercup-like flowers. **Seeds 15c packet, 3 for 40c. postpaid**

## GROUND ALMONDS

Amazingly Prolific—Easily Grown From Seed. The Ground Almond has a flavor that is MOST EXCELLENT, resembling the coconut. The meat is snow white, covered with a shell or skin of brown color. It grows close to the surface and anything from 200 to 300 Almonds may be expected from a single bush. It is always the object in growing anywhere and in any kind of soil. May be planted any time, and in eight or ten weeks from time of planting you will have an **LOAF** of the MOST DELICIOUS ALMONDS YOU EVER TASTED. **Seeds 15c Pkt.**

## Chinese Cabbage

Novelty from China and should be grown in every garden. Seems to be a cross between Celery and Coe Lettuce, but is much more mild than any other cabbage. Can be served on the table and eaten raw or cooked like cabbage, spinach or lettuce. It is a vegetable that is easy to grow. Grows very rapidly. 6 to 7 inches high. You can create quite a reputation by cultivating this remarkable novelty. **Seeds, 15c packet, 3 pkts. for 40c.**

## TREE OF HEAVEN

This splendid ornamental tree is a native of China and is called the Tree of Heaven on account of its great beauty. Very hardy, thrives in any soil, no matter how poor, and grows from 6 to 10 feet high from seed the first summer. The leaves are from 6 to 6 inches in length, giving it a grand appearance. Nothing outside the tropics can rival it for its decoration. Large panicles of bloom, followed in season by great clusters of colored seed pods, make a continual thing of beauty. **Packet, 15c; 3 packets 40c**

## THE REMARKABLE FIREFLY PLANT

A Vine that Blooms at Night. Fill the Atmosphere with Fragrant Aroma. One of the most rapid growing vines known. Under favorable conditions this vine has been known to grow OVER 25 FEET IN A SINGLE WEEK. In a very short space of time a bush has climbed to great height, and is covered with IMMENSE FLOWERS, from 5 to 7 inches in diameter. It is, indeed, a great novelty, for, unlike other plants, the flowers are OPEN IN THE EVENING and remain open until about noon the following day. In dull weather they will remain open all day. It is a most INTERESTING SIGHT to see each of the glowing and glowing flowers as the clouds appear and disappear. As the flowers open they give forth the most DELICIOUS FRAGRANCE and the whole atmosphere is filled with an accented fragrance. It is always the object of favorable comment, and much curiosity is aroused by people passing at night (time as to the cause of the charming glow) will have an opportunity to satisfy their curiosity. **PRICE 10 CENTS packet, two packets for 35 CENTS. POSTPAID. JOHNSON SMITH & CO.**

## The Great Wonderberry

A luscious berry that may be grown and planted in any soil or climate in 3 months. The flavor is fine and unusual. It may be eaten raw, cooked, canned or preserved in any form. The fruit is blue-black in color, and tastes like a luscious rich blueberry. One bush will produce an enormous amount of fruit, yielding great masses of rich fruit all Summer and Fall. **Packet, 10c, 3 pkts. for 25c. postpaid.**

## Shoo Fly Plant

A very remarkable botanical curiosity you should have. Though quite odorless it is said it will remain in a room where it is grown. Bears very pretty blue flowers. Blooms Summer and winter. Grows rapidly from seed. **SEEDS 15c pkt. 3 for 40c. postpaid.**

## The Great Umbrella Palm

A Beautiful House of Japanese Conservatory Plant. Easily Grown From Seed Winter or Summer. The Japanese Umbrella Palm is a semi-aquatic plant. It is easily grown in a bowl of water or in very damp soil. Probably the most usual, as well as the most interesting method, is to cultivate the plant in a bowl or jar of water, with two or three inches of good garden soil at the bottom. The seeds soon commence to germinate, and the plant shoots up stems and leaves rapidly assuming a most pretty palm-like appearance, as shown in the engraving. The tops of the stems are surmounted by a whorl of umbrella-shaped leaves, of a most delicate and beautiful appearance. We will send a package of this seed, with full instructions for culture, for only 15c or three packets for 40c postpaid.

## Pertume Plant

Blooms only at night, giving forth the most delightful scented perfume for quite a distance. Causes much comment. For house or garden. Also valuable because of rare perfume made from it. **SEEDS, 10c PKT. 3 for 25c. postpaid.**

## CACTUS FROM SEED

Very curious, odd looking, strange species of plants; will thrive anywhere with little or no care. Flowers are of exquisite beauty and delightful fragrance. They will be astonished at the odd looks of the cactus. **Packet, 10c; three packets for 25c. postpaid.**

## GIGANTIC NEW GUATEMALA BUTTER BEANS

THE NEW EDIBLE VEGETABLE WONDER. Grows to an astonishing size, the beans measuring from 3 to 6 feet long, and weighing anything from 1 to 1 1/2 lbs. and even more. One bean is sufficient for 8 family for several meals. Very palatable and rich in nutritious materials. The delicate buttery flavor is much appreciated. The vines are tall, green, very prolific, and a most welcome and valuable adjunct to your garden. Try them; you will find them the most delicious vegetable you have ever tasted. Imported direct. Unobtainable elsewhere. Sample package of seeds with full directions for cultivating and growing. **SEEDS, 25c. postpaid.**

## Kudzu Vine

Most rapid growing vine known. Will grow 20 feet in one week. Luxuriant foliage, lovely purple flowers, very fragrant. Nothing to equal it for shade purposes and quick growth. **Seeds 15c packet, 3 for 40c.**

## Yard Long Bean

Produces enormous crop of long, slender, round pods, of excellent quality for snap beans. Pods grow from 2 to 5 feet in length. Very tender and fine flavor. The vines are rampant growers; an interesting curiosity. **Seeds 15c pkt., 3 for 40c.**

## REAL LIVE PET TURTLES

25c

**LIVE Delivery Guaranteed**

Sent by Mail for only 25 Cents

AFASCINATING AND INTERESTING PET

If you want a fascinating and interesting little pet, just risk 25c and we will send you a real live PET TURTLE by mail postpaid. Thousands sold at Chicago Worlds Fair. No trouble at all to keep. Just give it a little lettuce or cabbage or let it seek its own food. Extremely gentle, easily kept and live for years and years. Need less attention than any other pet. Get one or more. Study their habits. You will find them extremely interesting. **Price 25c. SPECIAL TURTLE FOOD 10c pckg.**

## ADDRESS ORDERS FOR GOODS ON THIS PAGE TO

**JOHNSON SMITH & CO. RACINE, WIS.**

DEPT. 946

Our complete Catalog sent on receipt of 10c., or the De Luxe Cloth Bound Edition for 25c. Bigger and better than ever. Only book of its kind in existence. Nearly 800 pages of all the latest tricks in magic, the newest novelties, puzzles, games, sporting goods, rubber stamps, unusual and interesting books, curiosities in seeds and plants, etc., unobtainable elsewhere. Remit by Coin, Money Order, Check or unused U. S., Canadian and Foreign Stamps for all articles listed above.



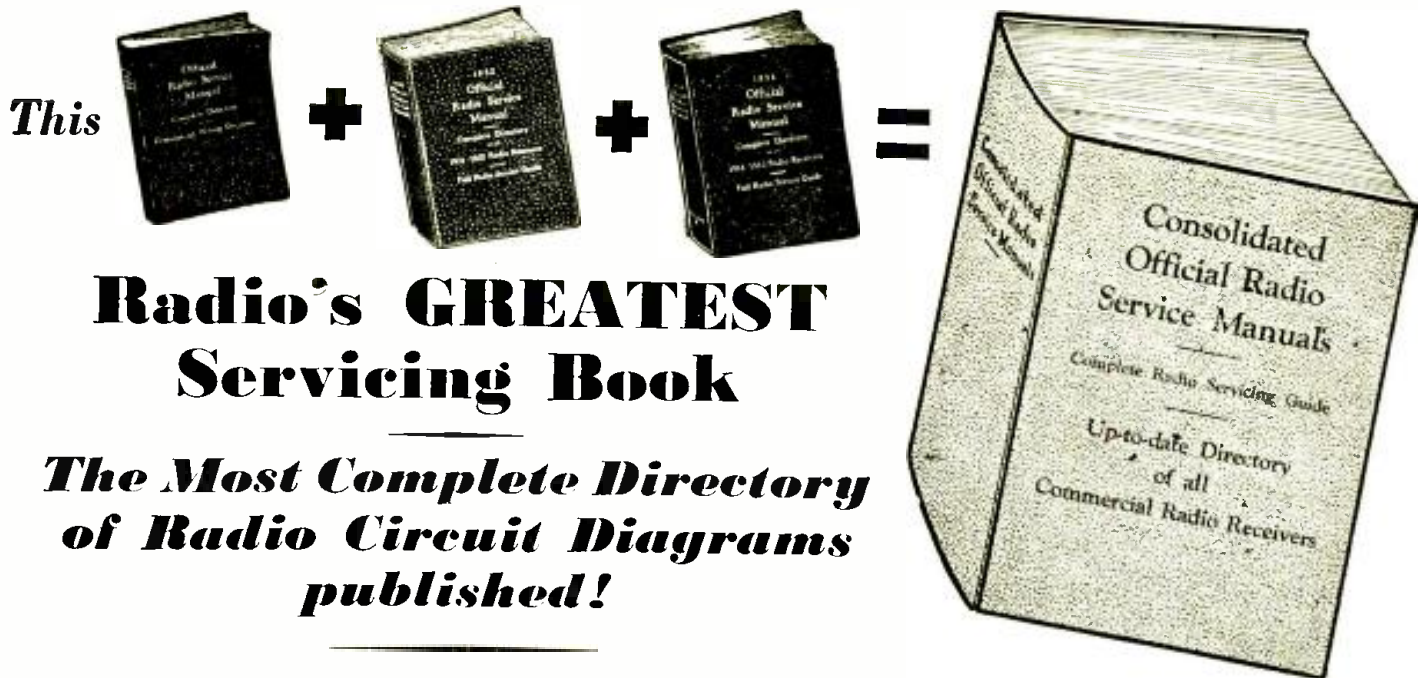

# Radio's GREATEST Servicing Book

*The Most Complete Directory of Radio Circuit Diagrams published!*

**In ONE VOLUME of over 2,300 Pages**  
**Extra Heavy Cover—Looseleaf Bound**

Buy this Big Volume on our *New*

## DEFERRED PAYMENT PLAN

Here are two of the most surprising announcements that we have ever made to the radio trade and we know that it is such good news that every radio man will be greatly enthused.

FIRST—that the three editions of the OFFICIAL RADIO SERVICE MANUALS have now been combined into one big volume of over 2,300 pages.

SECOND—that this new single volume of consolidated radio circuit diagrams and complete radio servicing course can be bought on a deferred payment plan—and at a big saving.

It is needless to say how valuable the OFFICIAL RADIO SERVICE MANUALS have been to members in every branch of the Radio Industry, and how many thousands of each edition have been sold to manufacturers, jobbers, dealers, Service Men and experimenters. But we must emphasize this one fact: Service Men now realize that they are tremendously handicapped without the full set of Gernsback Manuals. So much so, that those who have purchased only one or two volumes, are NOW ORDERING THE MISSING BOOKS. They want their files to be complete.

The complete book gives you a volume of over 2,300 pages with over 5,500 diagrams, charts and photos. There are absolutely no pages or illustrations or diagrams duplicated. There is no radio book published today which is so mod-

ern, up-to-the-minute, and which contains so much useful information as is to be found in this single volume. It is a book that will outlast any other radio book in print. Look carefully at the illustration of the complete edition on the top of page. It measures 9" wide, 12" long, 4½" thick.

Included in this volume is a complete radio servicing course. This course covers every step needed to learn the servicing business . . . from starting in business . . . materials needed . . . and how to go about servicing receivers and repairing other radio equipment. This course in itself, is actually worth the price of the entire book.

Our new plan now enables every radio man to get this single volume—a Complete Directory of all Circuit Diagrams, of over 2,300 pages, on deferred payments. You can order this book immediately—get it in a few days, and use it while you are doing servicing work. You can make the first few calls pay for the entire cost of the book.

For you to get this book is quite simple and it is sent to you as soon as your order is received. You pay for it in small monthly amounts which can be taken from your earnings. If you were to buy the three volumes separately, the total cost would be \$17.00, including the supplements.

Now you can get the

1931 OFFICIAL RADIO SERVICE MANUAL, with Supplements,  
 1932 OFFICIAL RADIO SERVICE MANUAL, with Supplements,  
 and the 1933 OFFICIAL RADIO SERVICE MANUAL Complete

at a big saving.

THE SPECIAL NEW PRICE FOR ALL THREE MANUALS, WITH SUPPLEMENTS, IN ONE VOLUME, WITH HEAVY BINDER IS ONLY

**\$1-1.00**

You buy this book this way—

Send \$3.00 with order—

Pay \$5.00 to Express Company upon receipt of book.

Send \$3.00 thirty days after receipt of book.

Send \$3.00 sixty days after receipt of book.

Total \$14.00.

IF THE ENTIRE AMOUNT IS SENT WITH YOUR ORDER, WE WILL ALLOW YOU A 10% DISCOUNT. THIS CAN BE DEDUCTED FROM YOUR REMITTANCE.

IMMEDIATE SHIPMENT

**Mail Coupon Today!**

GERNSBACK PUBLICATIONS, Inc.,  
 96-98 Park Place, New York, N. Y.

Gentlemen:

In accordance with your Special Offer, I enclose herewith \$3.00 as first payment toward the One-Volume Radio Manual. Please forward it to me promptly. Upon receipt of the book, I shall pay express company \$5.00. Thirty days later I shall send you \$3.00, and sixty days after receipt of book, I shall send you my last payment of \$3.00.

If you want to take advantage of the Special Discount of 10%, remit only \$12.60 with this coupon.

Name \_\_\_\_\_

Address \_\_\_\_\_

City \_\_\_\_\_ State \_\_\_\_\_

BC-434

**OVER 2,300 Pages**  
**5,500 Illustrations**

**THIS IS THE GREATEST SINGLE VOLUME RADIO BOOK IN PRINT TODAY**

GERNSBACK PUBLICATIONS, Inc.

96-98 Park Place

New York, N. Y.

# HERE IS A GROUP OF FINE QUALITY RADIO PARTS THAT "Shouts" ..

# VALUE!

## Mershon Triple 10 Mfd. Electrolytic Condenser



A genuine Mershon Electrolytic condenser at this low price for the first time. Contains three 10 mfd. condensers in one. Used as a replacement in many different receivers. Proven design, puncture proof, constant capacity—are the features which distinguish this condenser from others.

Positive terminal leads are brought out to bolts on top of the condenser. Negative is grounded to the container.  
Price ..... **\$1.25**

## POWERTONE SENDING KEY

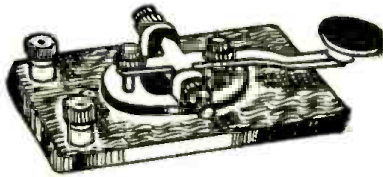

This popular design is widely used as a low power transmitting and code practice key. Mounted on a mahogany finished base. The key is well-balanced and fully adjustable for clearance and tension. Contacts are designed for heavy service. A commercial key at the amateur's price. Base dimensions 3 1/4 inches long and 2 3/8 inches wide.  
Price ..... **79c**

## CROSLY POWER TRANSFORMERS

Constructed of the finest materials. Large oversized construction insures freedom from heating. Massive core and oversized coil provides long trouble free life.

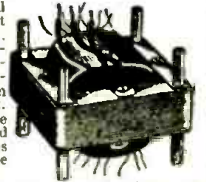

B. H. model supplies the following voltages:  
1 1/2 volts for 4-226; 2 1/2 volts at 2 amps. for 1-227; 5 volts at 1/4 amp. for 1-171A; Winding for Raytheon Type B. H. tube; 250-250 High voltage; Primary 110 volts A.C. 60 cycle. Price ..... **\$1.00**

## Fast .06-.06 Condenser



A high grade by-pass condenser made by one of the foremost condenser manufacturers in the country. Contains two .06 condensers in one can. Separate terminals are brought out for the common connection and both positive. Can is not grounded.  
Price ..... **12c**



## 60,000 ohm Ward Leonard Vitrohn Resistor

A high grade well known heavy duty resistor. Will dissipate 25 watts continuously. Total resistance is 60,000 ohms tabbed at 1500. Comes completely mounted on a bakelite strip to ease installation. Bakelite strip measures 4 inches in length and 1 3/4 inch wide. Price ..... **19c**

## 4 Prong Bake- lite Socket



We bought a great quantity of these sockets before the price rise. Here is your chance to stock up. They will go fast at this low price—send in your order now. Phosphor-bronze contacts assure permanent connection. Price ..... **5c**

## CROSLY DOUBLE CHOKE



A unit consisting of two chokes which can easily be separated. Each choke is rated at 30 henries at 60 mills. Sturdily constructed and will handle an overload of 15%. Fully shielded in an attractive black enameled can. Measurements 3 3/4 ins. long, 2 1/2 ins. high, and 2 3/8 inches wide. Each choke contains separate terminals. Price ..... **69c**

## R.C.A. VICTOR HAND MIKE

Provides true toned reproduction of music and voice. Ideal for use in home recording systems, and as a home broadcasting system. Widely used in a amateur portable public address systems. Neatly finished in brown gun metal enamel—complete with 5 foot cord.  
Our Price ..... **\$1.25**

## FARRAND INDUCTOR DYNAMIC SPEAKERS—9" MODEL



The ideal short wave receiver speaker; eliminates hum and line noise; draws less current; absolutely genuine Farrand; Compact in size; brings in the very weak short wave stations.

Do not confuse this model with the various similar types on the market posing as Farrands.

This is the true Farrand Inductor Dynamic. Its adaptation to Short Wave Radio Receivers has proven a popular step. The most inaudible stations are brought in with remarkable clearness without the customary noise and hum of regular dynamic speakers. Has two magnets parallel to each other with a bracket placed between them to facilitate mounting. Overall 9" model. Please state power tube when ordering.  
Price ..... **\$3.95**

## 12" MODEL

The Genuine Farrand Inductor For The First Time At This Low Price

These models are not to be confused with the various types now on the market and labeled Farrand Inductors. These models are all factory built and not just put together haphazardly.

The 12 inch models have two magnets standing upright, with a bracket on the bottom to ease mounting. Dimensions of the 12 inch model: 12 inches high and 6 1/2 inches deep. (12" Model)  
Our Price ..... **\$4.95**

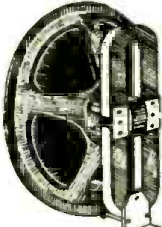

## GENUINE R. C. A. MAGNETIC CHASSIS



This chassis is the identical one used in the R.C.A. 100A-100B Speakers which list for as high as \$35.00. Note built-in output transformer which permits use of 450 volts without distortion, rattling or blasting. Generous oversized magnet. The thick armature is accurately centered, the sturdy metal frame is lined with a special self-buffing fabric, greatly improving acoustic properties of this sensational speaker. Note the corrugated surface of the cone, an exclusive feature—enhances perfect reproduction qualities considerably; most compactly made; 9" outside diameter, 4 1/2" deep overall.  
Price ..... **\$2.50**

## Replacement Unit

The genuine replacement unit mechanism for the R. C. A. 100A, 100B, and 103 speaker chassis. This unit is complete in every detail except that it is furnished less the magnet. Guaranteed to be in perfect condition. Can also be used for replacement purposes on any other type speaker.

Our Price ..... **95c**  
With Magnet ..... **\$1.25**

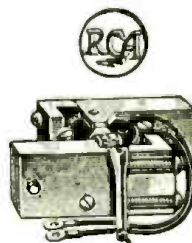

## BALDOR Television Motor

A silent synchronous motor used in the Jenkins Television receivers. All genuine brand new Baldor Motors.

**SPECIFICATIONS**  
Type M 2 C R  
H. P. —1/15  
R. P. M. —1700  
Volts —110 volts  
A.C. 60 cycle  
Amp. —1.0  
Ph.—1

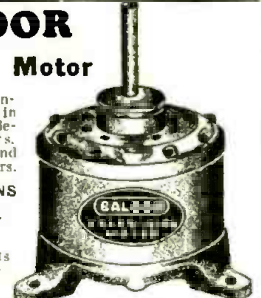

Standard shaft 3 1/4 inches long. Overall height 8 inches. Width 4 3/8 inches.  
Price ..... **\$6.95**

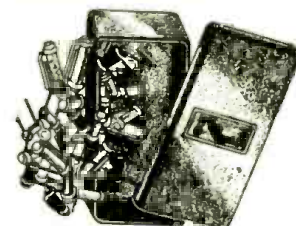

Handy  
Kit of  
50  
R.M.A.  
Color  
Coded  
Resistors  
1/2-1/3-  
1-Watt

A complete assortment of resistors which will prove invaluable to the service bench. Their long tinned leads and small size permit easy insertion or replacement. A complete kit and easy to carry. Odd values can be obtained by connecting two or more values in series or parallel. R.M.A. color coded for easy identification.  
**FREE**—With each assortment of 50 resistors a beautiful bakelite case—a souvenir of the Chicago Century of Progress Exposition. Size of box: 3 1/4 x 3 1/4 x 1 3/8 inches.  
Price ..... **\$2.95**

All orders are F. O. B. New York, and subject to prior sale. Terms: A deposit of 20% is required with every order. Balance may be paid on delivery. Deduct 2% if full amount is sent with order.  
**DO NOT SEND FOR CATALOG**

## GRENPARK COMPANY

245 Greenwich St. Dept. RC New York, N.Y.



# SALE OF ORIGINAL

# Majestic

All Parts Used in MAJESTIC Receivers Have  
Been Known to Be of the Highest Quality

## REPLACEMENT PARTS

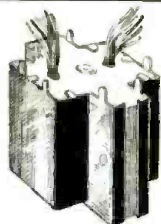

### FILAMENT AND PLATE TRANSFORMER

Model No. 25  
Primary 115 volt 25 cycle  
Secondary to anode center tapped  
Secondary 5 volt 2 amp.  
Secondary 2.5 volt 7 amp.  
Secondary 2.5 volt 7 amp. center tapped  
Weight 13 lbs.

Original Majestic Part No. 5883

**\$3.45** Each

### FILAMENT AND PLATE TRANSFORMER

Model No. 23A  
Primary 115 Volt 60 Cycle  
Secondary to anode center tapped  
Secondary 5 Volt 2 Amp.  
Secondary 2.5 Volt 7 Amp.  
Secondary 2.5 Volt 3 Amp. center tapped  
Weight 20 lbs.

Original Majestic Part No. 2156

**\$3.65** Each

### FILAMENT AND PLATE TRANSFORMER

Model No. 10 Converter  
Primary 110 Volt 50-60 Cycle  
Secondary to anode center tapped  
Secondary 5 Volt 2 Amp.  
Secondary 2.5 Volt 3 Amp.  
Weight 4 lbs.

Original Majestic Part No. 6411

**\$2.29** Each

### UNIVERSAL POWER TRANSFORMER

Primary 110, 120, 150, 200, 220, 240 Volt  
Cycle 25, 100  
Secondary to anode center tapped, supplies 385 Volt D.C. at 140 M.A.  
Secondary 2.5 Volt 3 Amp. for No. 82 rectifier  
Secondary 2.4 Volt 7 Amp., center tapped  
Secondary 2.4 Volt 4 Amp., center tapped  
Weight 13 lbs.

Original Majestic Part No. 9529

**\$3.95** Each

### UNIVERSAL POWER TRANSFORMER

Primary 110, 120, 150, 200, 220, 240 Volt  
Cycle 25, 100  
Secondary to anode center tapped, supplies 380 Volt D.C. at 120 M.A.  
Secondary 2.5 Volt 3 Amp. for No. 82 rectifier  
Secondary 2.4 Volt 13 Amp., center tapped  
Weight 13 lbs.

Original Majestic Part No. 9478

**\$3.95** Each

### FILAMENT AND PLATE TRANSFORMER

Model No. 130A—Chassis 131-132-133  
Primary 115 Volt 60 Cycle  
Secondary to anode center tapped  
Secondary 5 Volt 2 Amp.  
Secondary 2.5 Volt 7 Amp.  
Secondary 2.5 Volt 3 Amp., center tapped  
Weight 16 1/4 lb.

Original Majestic Part No. 891

**\$3.45** Each

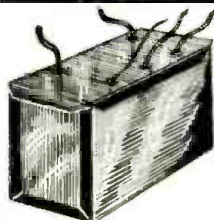
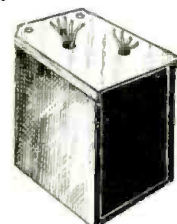

### PICKUP TRANSFORMER

Model No. 135  
Weight 3 lbs.

Original Majestic Part No. 5532

**89c** Each

### PICKUP INPUT TRANSFORMER

Model No. 155

Original Majestic Part No. 5578

**89c** Each

### PICKUP INPUT TRANSFORMER

Model No. 100  
Weight 3 lbs.

Original Majestic Part No. 468

**89c** Each

### PUSH-PULL INPUT TRANSFORMER

Model No. 30  
Weight 4 1/2 lbs.

Original Majestic Part No. 3624

**89c** Each

### PUSH-PULL INPUT TRANSFORMER

Model No. 100B-90B  
Weight 4 1/2 lbs.

Original Majestic Part No. 1551

**89c** Each

### PUSH-PULL OUTPUT TRANSFORMER

Model No. 30  
Weight 3 lbs.

Original Majestic Part No. 3053

**69c** Each

### CONDENSER BANK

For No. 100B and 90B

Original Majestic Part No. 1585

**\$1.79** Each

### CONDENSER BANK

Contains 3-2 mfd.

Original Majestic Part No. 1258

**\$1.49** Each

### BY-PASS CONDENSER ASSEMBLY

Model No. 35  
Contains 4-1/10 mfd.  
Weight 1 lb.

Original Majestic Part No. 5792

**69c** Each

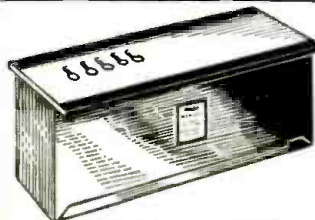

### CONDENSER BANK No. 7BP3

Weight 6 1/2 lbs.

Original Majestic Part No. 716

**\$1.49** Each

### CONDENSER BY-PASS ASSEMBLY

Model No. 390

Original Majestic Part No. 9167

**69c** Each

### BY-PASS CONDENSER AND TERMINAL STRIP ASSEMBLY

Model No. 200

Original Majestic Part No. 6298

**69c** Each

### CONDENSER ASSEMBLY

Model No. 340B  
Original Majestic Part No. 9013

**69c** Each

### CONDENSER ASSEMBLY

Model No. 25 and 25B  
Weight 3 1/4 lbs.  
Original Majestic Part No. 5607

**69c** Each

### CHOKE ASSEMBLY

No. 7P3  
Dual choke  
Weight 5 1/2 lbs.  
Original Majestic Part No. 712

**89c** Each

### FILTER CHOKE UNIT

Model No. 50  
Weight 5 lbs.  
Original Majestic Part No. 3051

**89c** Each

### DOUBLE CHOKE FOR 90 SERIES

9P6 power pack  
Weight 8 lbs.  
Original Majestic Part No. 281

**\$1.19** Each

### SINGLE CHOKE FOR 70 SERIES

7P3 power pack  
Weight 5 lbs.  
Original Majestic Part No. 640

**89c** Each

## ORDER FROM THIS PAGE

*Do Not Write for Catalog*

No orders for less than \$2.00 accepted. No C. O. D.'s. All shipments will be forwarded by express collect if not sufficient postage included with your order.

WELLWORTH TRADING CO., RC 434  
111 W. Lake St., Chicago, Ill.

Enclosed find \$.....for which ship to address below the following MAJESTIC parts:.....

Name .....

Address .....

City .....State .....



# YOUR DOLLAR IS WORTH MORE

## When You Buy From Us

IS the dollar inflated? These days everyone is speaking of inflation. But who cares? Whether it is or not, your dollar is worth more when you buy from us. The prices on this page are so radically low that no one can possibly undersell us. Every month we list on this page a few STAR (\*) items which are not listed in our regular catalog. These are all special items of which the small quantity on hand does not permit us to catalog them. **ONCE SOLD OUT, NO MORE CAN BE HAD AT ANY PRICE. ORDER TODAY—NOW.** Order direct from this page and save money. 100% satisfaction guaranteed on every transaction. Take advantage of these special offers while they are still available. **STOP SHOPPING—WE SHOP FOR YOU AND GIVE YOU THE LOWEST PRICES.**

### COLONIAL REMOTE CONTROL ATTACHMENT

Complete . . . Nothing Else to Buy

Imagine the convenience of just sitting back in an easy chair or lying in bed and merely by pressing a series of buttons, starting the radio located in a far off room or hidden away in the basement. Not only that, but selecting one of ten stations from a remote point. If this is the machine age, it is also the age of convenience. The remote control is a machine designed to tune your radio automatically. Why not take advantage of it, especially when it is priced more than 300% below its original list value.

This remote control outfit was used on one of the Colonial remote control receivers which sold for more \$300.00; yet you or anyone at all handy with tools can attach it to your own radio. You can then hide the radio either in the closet, basement, or some other out-of-the-way place and extend wires to any number of speakers, strategically located in various parts of your apartment. Imagine the surprise of your friends or guests at dinner or at special gatherings, when, by merely pressing a button the room is gradually flooded with beautiful music or other entertaining programs, by the hidden speakers. Aside from being a novel idea it is also a very practical one.

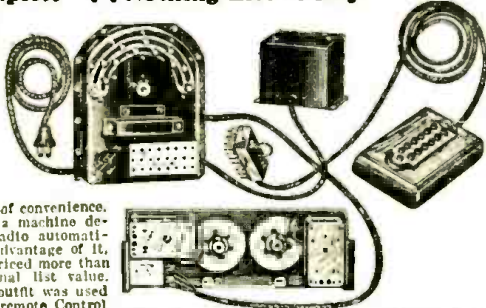

**RADIO SERVICE MAN AND CUSTOM SET BUILDER—Here is Your Opportunity!** You need but mention the words "remote control" to your customer and immediately you command his entire interest and attention. You are able to do this because the idea to him, is new and because it immediately implies expensive equipment. However, when you inform him that you can construct or ADAPT HIS RECEIVER FOR REMOTE CONTROL OPERATION for only a few dollars more, his interest will most certainly materialize into an order. We need not give YOU any more talking points on this subject because you probably can muster up more than we.

#### EXTREMELY SIMPLE TO OPERATE

The outfit comprises two small motors (one for turning the tuning condenser and the other for turning the volume control), a 10-position commutator switch for selecting 10 different stations, a step-down transformer for energizing the motors and a 13 button control board (10 buttons for the 10 stations, two buttons for increasing or decreasing the volume and one button for silent tuning). A pilot light in this control board indicates when the receiver is operating.

If the shafts of the tuning condenser and volume control of your present receiver can be extended so that the commutator switch section and one of the motor gears can be slipped over the tuning condenser shaft and the other motor gear on the volume control shaft then you can easily adapt this outfit to your receiver DIRECTLY without any further changes. With some sets it may be necessary to remove the volume control entirely from the chassis and mount it directly on the gear of the volume control motor. Custom set builders need have no headaches about this remote control, inasmuch as they can design the physical layouts of their sets to conform with this equipment. The illustration clearly shows all component parts of this complete remote control system. Shipping weight 18 lbs.

No. 1789 Colonial Complete Remote Control Outfit  
YOUR PRICE..... **5.96**

### Greatest Buy in America?

#### Pilot Six-Tube Two-Volt Battery Receiver

**COMPLETE, NOTHING ELSE TO BUY**

There are ONLY 20 of these battery receivers available. ACT FAST if you desire to have one at this low price. Every one is familiar with the fine quality and performance of Pilot receivers. Their precise engineering and elaborate design has made them famous throughout the world. A fortunate buy permits us to sell these 6 tube 2-volt receivers at a price which is almost 300% below list.

This receiver may be operated from a storage battery as well, without any additional changes. Uses 2-30's, 2-31's and 2-32's. These tubes are arranged in a highly sensitive tuned radio frequency circuit which assures stability throughout the entire life of the set. Every component part, including the tuning condenser, are thoroughly shielded to prevent stray signals from entering the circuit. A large 8" magnetic speaker, specially designed to work from push pull tubes, reproduces the programs with a clarity which compares favorably with the original rendition. Both chassis and speaker are mounted in a two-toned cabinet of special columnaire design. The four controls on the front panel are respectively: automatic control, station selector, "on off" switch and tone control. The cabinet measures 18" high by 16" wide by 9" deep. Shipping weight 30 lbs.

No. P-200—Pilot 6 Tube 2-Volt Battery Receiver, Less Tubes. **\$13.52**  
YOUR PRICE.....  
Complete set of tubes for this receiver..... **\$4.82**



### Don't Junk Your Old Tube Checker! Modernize it With This Multidapter

Contrary to popular belief the advent of the seven prong and other new tubes has not rendered your tube checker obsolete. Why throw away an expensive tube checker when it can be easily, without any internal changes, brought up to date? You merely plug this new Multidapter into the four prong socket of your present tube checker and you are all equipped to test every tube that was ever placed on the market. The legends of more than 60 of the new tubes are lithographed directly on the front panel of the Multidapter.

Furthermore, the unit is so flexibly constructed that the operator has access to every single element of any tube. In other words, aside from being able to make standard tests, every conceivable other test desired by any serviceman or experimenter can be readily made through the manipulation of four plugs and the series of tube jacks, symmetrically arranged on the front panel. This feature makes the unit a perpetual instrument. Shipping weight 3 lbs.

No. 205—Multidapter  
YOUR PRICE..... **\$7.52**



### Servicemen's Wire Wound Fixed Resistor Kit

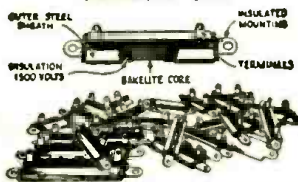

You have probably never seen or used a resistor of this type. It is new, it is radically different from other resistors, both in construction, accuracy and maintenance of calibration. These resistors are "ALUMINUM" in the strictest sense of the word. A heavy steel covering around fine wire element protects it indefinitely and prolongs its life. A RESISTOR OF THIS TYPE MAY BE USED OVER AND OVER AGAIN, FROM SET TO SET, WITHOUT LOSING ITS CALIBRATION OR WEARING OUT.

The kit consists of 24 resistors, only 4 of which are duplicated. In other words there are more than 20 different values. If these units were bought individually they would cost more than \$8.50. Manufacturers and custom set builders are rapidly becoming aware of the fact that these resistors defy adverse conditions. They will stand a considerable overload without breaking down. It is quality merchandise of this kind which builds up the business and reputation of a serviceman or custom set builder because "cheap things are expensive in the long run."

#### CONTENTS OF KIT

The kit contains one each of the following values: 20 ohm C.T., 40 C.T., 60 C.T., 50 ohms, 100, 150, 250, 300, 400, 600, 1250, 1500, 2000, 2500, and 5000; and two each of the following 200 ohms, 500, 750 and 1000. Shipping weight 3 lbs.

No. "MU-KIT"—Servicemen's Wire Wound Fixed Resistor Kit.  
YOUR PRICE..... only **\$2.24**

### A REAL MICROPHONE at the Price of a Toy

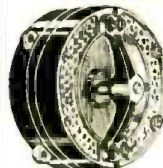

Here is the largest value ever offered in a commercial type microphone! An unusually large two-button microphone, ruggedly constructed and designed especially for broadcast purposes. Frequency range 30 to over 5,000 cycles—adequate for all speech and music reproduction. EXCELLENT FOR PUBLIC ADDRESS WORK. Stretched cushioned diaphragm of duralium with pure gold center contacts on buttons and diaphragm. Standard 200 ohms per button. Finished in beautiful polished chrome. Net weight 1 1/2 lbs. Shipping weight 2 1/2 lbs.

No. "F" 2 Button Mike.  
YOUR PRICE..... **\$4.96**

### High Emission 201-A Tube

This tube may be called a "cross" between a 71-A and the 201-A. It has the M type filament of the former and the characteristics of the latter. In other words it is a 201-A tube, which, due to its "M" shape filament has a very high electronic emission. This means high plate current. These characteristics make it exceptionally suitable for use as an oscillator in transmitters or in receivers. May be used to advantage as oscillators in 5 and 10 meter transmitters. Filament voltage 5 volts, filament current—25 amps, maximum plate voltage 157 volts. Shipping weight 1/2 lb.

No. ZRF—High Emission 201-A Tube  
YOUR PRICE..... each **\$0.22**



# FREE RADIO AND SHORT WAVE TREATISE

108 Pages

### Over 100 Hook Ups—1500 Illustrations

Every time a new edition of our RADIO AND SHORT WAVE TREATISE comes off the press it is an event.

This completely revised and enlarged 1934 edition contains 108 solid pages of useful radio information, diagrams, illustrations, radio kinks and real live radio merchandise. It contains more valuable radio information—more real live "meats"—than many textbooks on the subject.

**PARTIAL LIST OF CONTENTS**

Chapter Two of "Fundamental Principles of Radio for the Beginner"—The New Tubes, Their Uses, and Their Fundamental Circuits—How to Make Money with Public Address Systems. How to Build the "R.T." Beginner's Transmitter—How to Build the Famous Twinplex Short Wave Receiver—How to Construct an Amateur Radio Transmitter—A Most Modern and Complete Tube Chart, Including Socket Connections for all Tubes—Numerous Free Offers, etc.

Enclose 4c for postage. Treatise sent by return mail.

WE ARE A WHOLESALE HOUSE AND CAN NOT ACCEPT ORDERS FOR LESS THAN \$3.00.

IF C.O.D. shipment is desired, please remit 20% remittance, which must accompany all orders.

If full cash accompanies order, deduct 2% discount. Send money order—certified check—U. S. Stamps.

**ORDER FROM THIS PAGE** You will find special prices from time to time, in this magazine. Get our big FREE catalog for the greatest Radio Bargains.

Should you wish goods shipped by parcel post, be sure to include sufficient extra remittance for same. Any excess will be refunded.

**Radio Trading Company 102 Park Place New York, N. Y.**